



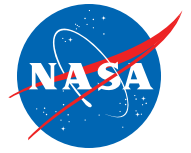
# The International Space Station

## Operating an Outpost in the New Frontier



*Executive Editor*  
**Robert Dempsey**





# The International Space Station

## Operating an Outpost in the New Frontier

*Executive Editor*  
**Robert Dempsey**

*About the cover:*

*The flight director watches over the men and women of Houston's Mission Control, the bastion that protects the astronauts on the International Space Station. In the background, the space station, as seen from the space shuttle Atlantis on its last mission, orbits the Earth. The station has been continually inhabited, 24/7, since October 31, 2000.*



To the women and men  
of mission control  
who keep ever vigilant.

And to their families  
for supporting,  
and putting up with,  
their dreams.

# Foreword

Over a span of 20 years, the vision of an international orbiting outpost—one with continuous human presence, measuring the size of a football field, with mass of ~900,000 lbm, and orbiting the Earth every 90 minutes—became a reality. The International Space Station (ISS) is a testament to what engineering miracles can be accomplished with vision, leadership, perseverance, political support, and funding. The ISS enables world-class scientific research, forges pathfinders for future exploration travel, and unites 15 international partners working together with common goals to keep the ISS viable.

We are grateful for the visionaries who planted the seeds of continuous human presence in space, beginning with science fiction books and movies that stretched the limits of our imagination. These futuristic dreams inspired technologies required to support civilian spaceflight and military endeavors that, over time, have not only turned out to be possible but are now part of our everyday life.

The ISS is part of NASA's ongoing, deliberate, step-by-step approach for expanding the boundaries associated with human spaceflight exploration that will return us to the moon and eventually to inhabiting Mars. The ISS Program stands proudly on the shoulders of giants who accomplished increasingly complex and ambitious space projects. The early Mercury rockets demonstrated our ability to safely leave Earth's atmosphere with human passengers, followed by the Gemini and Apollo projects, which were pathfinders for spacewalks, rendezvous, dockings, and human moon landings. The Skylab and Mir space stations, along with the Apollo/Soyuz program, established collaborations with international partners and demonstrated that we could safely operate long-term in low-Earth orbit. A winged Space Shuttle, with the capability to achieve low-Earth orbit for extended periods, enabled astronauts to conduct scientific research and to deploy, retrieve, and repair payloads and satellites. All of these experiences culminated with the adventure of assembling the ISS in low-Earth orbit, testing the ability of engineers, operators, astronauts, scientists, and numerous others working as a team with common goals.

Beginning in 1998, the ISS evolved from two modules—one Russian and one American—into a complex composed of 14 elements operated by 15 countries that provides a continuously operating laboratory expanding the scientific boundaries of both physical and biological sciences. The ISS creates a stable platform for studying the effects of long-term human presence for life support, propulsion, electrical, and structural systems to allow humans to explore further. This will lead to technologies and operational techniques for longer-duration spaceflights, a deep space outpost, a permanent base on the moon, and eventually a human outpost on Mars.

The flight directors involved in the planning and assembly of the ISS played a vital leadership role in planning, training, orchestrating, and executing each mission. Of the current 91 flight directors in NASA human spaceflight history, more than half of them have worked directly with planning and assembly of the ISS. This Flight Operations leadership and dedication helped to pave the way for the tactical real-time assembly of an operationally evolving spacecraft, knitting together individuals and teams from astronauts to design engineers who were all oriented toward the same strategic goal.

We would be remiss to not mention that the ISS would never have become a reality without the ISS Program and Space Shuttle Program leadership providing the overarching vision, funding, and integration with the international and commercial partners. Countless individuals and teams support these programs in critical roles and have dedicated their lives to developing, assembling, and now keeping the ISS a reality.

As we embark on new initiatives requiring human presence farther into the solar system, the Flight Operations team will carry with it the legacy of operational experience necessary to continue turning dreams into reality, all in support of NASA's exploration goals.



**Brian Kelly**

*Director, Flight Operations*



**Patrick Forrester**

*Chief Astronaut, Flight Operations*



**Norman Knight**


*Chief Flight Director, Flight Operations*

# Preface

Throughout my childhood, I was blown away, and inspired, by the amazing feats that NASA was accomplishing: walking on the moon; sending probes to Venus, Mars, Jupiter, and Saturn; flying a reusable Space Shuttle; and building space stations. Twenty years ago, I got the privilege of joining the NASA team, in particular in the famed and historic Mission Control. I realized early on that success was not built on technological marvels but on the shoulders of the men and women who worked at NASA. It was the men and women who laid awake at night and worried about what could possibly go wrong. It was the men and women who put all their passion into making sure the systems and the procedures, often challenged by tight budgets or a changing political climate, met the mission objectives. These engineers and scientists work in numerous directorates in various cities across the country to support the International Space Station Program. The Program office then turns to the Flight Operations Directorate to operate the space station. When the mission is occurring, it is the people in Mission Control who are on the front line to protect the lives of our astronauts, also members of our team, while ensuring mission success. We spend much of our time in consultation with the engineers, trying to anticipate problems in advance so that we are prepared for any eventuality. But when a problem occurs, things become truly extraordinary. That is when the people of NASA—all of NASA—put aside personal commitments and differences, roll up their sleeves, and work together nonstop until the issue is resolved. In fact, the passion of these people makes the job look so easy. The general public does not have a full understanding of what is involved in either the successful missions or those hit with a serious malfunction. That is why we chose to write this book. We want the reader to get a glimpse into what we do in our daily lives in Mission Control.

This is an unusual book. Half the chapters are devoted to operations, meaning what we do in real time during a mission. For the International Space Station, real time is continuous 365 days a year, 24 hours a day. These chapters will describe different operational aspects of “flight control.” However to get the full context, the remaining chapters will provide technical descriptions of the primary space station systems. Although not strictly required to understand the operations, they are intended to provide more information for proper context. Hopefully, these chapters are not too dense for the reader.

A complete list of specific people to acknowledge, of which there are many, is in the back of this book. However, this project would not have been possible without the help, support, and full backing of the directors of the Flight Operations Directorate at Johnson Space Center, Paul Hill and Brian Kelly. Ginger Kerrick was also key in helping to find the financial support to back the director’s support. I must also thank my wife, Dorothea Lerman, who literally helped birth the book and provided early editing and feedback. Finally, we must acknowledge all the men and women who have worked in Mission Control from the first flight director, Christopher Kraft, to today. Literally everything we do today is based on lessons they learned and techniques they developed.

  
**Robert C. Dempsey**  
*Flight Director, Flight Operations*

*Ad Astra Per Aspera*

# Table of Contents

Dedication	iii
Foreword	iv
Preface	v
Introduction	ix
<b>Chapter 1</b> Systems: International Space Station Planning—A Roadmap to Getting It All Done	1
<b>Chapter 2</b> Day in the Life: Living and Working in Space and on the Ground	19
<b>Chapter 3</b> Systems: Structure and Mechanisms—The International Space Station’s Skeleton	35
<b>Chapter 4</b> Day in the Life: The Making of a Mission	61
<b>Chapter 5</b> Systems: Command and Data Handling—The Brains of the International Space Station	91
<b>Chapter 6</b> Day in the Life: “Brain Transplants” on the International Space Station	109
<b>Chapter 7</b> Systems: Motion Control System—Navigator of the Heavens	119
<b>Chapter 8</b> Day in the Life: Debris Avoidance—Navigating the Occasionally Unfriendly Skies of Low-Earth Orbit	139
<b>Chapter 9</b> Systems: Electrical Power System—The Power Behind it All	155
<b>Chapter 10</b> Day in the Life: Preparing for the Unexpected	173
<b>Chapter 11</b> Systems: Thermal Control—the “Circulatory System” of the International Space Station	191
<b>Chapter 12</b> Day in the Life: Empty House—Decrewing the International Space Station	209



<b>Chapter 13</b>	Systems: Communications and Tracking—The Vital Link to the International Space Station . . . . .	<b>221</b>
<b>Chapter 14</b>	Day in the Life: Vital Visiting Vehicles—Keeping the Remote Outpost Crewed and Operating . . . . .	<b>233</b>
<b>Chapter 15</b>	Systems: Robotics—the Construction Equipment for the International Space Station . . . . .	<b>249</b>
<b>Chapter 16</b>	Day in the Life: In-Flight Maintenance . . . . .	<b>267</b>
<b>Chapter 17</b>	Systems: Extravehicular Activities—Building a Space Station . . . . .	<b>279</b>
<b>Chapter 18</b>	Day in the Life: Risky and Rewarding Spacewalks—Space Shuttle Mission STS-120/ISS-10A . . . . .	<b>305</b>
<b>Chapter 19</b>	Systems: Environmental Control and Life Support System— Supporting the Human Element of the International Space Station . . . . .	<b>333</b>
<b>Chapter 20</b>	Day in the Life: When Major Anomalies Occur . . . . .	<b>353</b>
<b>Appendix</b>	. . . . .	<b>379</b>
	Acronyms and Nomenclature. . . . .	<b>380</b>
	References . . . . .	<b>384</b>
	Acknowledgments . . . . .	<b>386</b>
	About the Authors . . . . .	<b>387</b>
	Index . . . . .	<b>390</b>



# Introduction

## Mission Control

***The International Space Station (ISS)—two-time nominee for the Nobel Peace Prize, and winner of the 2009 Collier Trophy—is a space outpost that is unfamiliar to many people.*** Behind this amazing feat of engineering is not just science and math but a team of devoted men and women from around the world and many walks of life that have made the ISS a success. These professionals comprise the Flight Control Team (FCT) of Flight Operations. This FCT is *the* Houston

in such famous phrases as “Houston, Tranquility base here. The Eagle has landed,” and “Houston, we’ve had a problem.” Although astronauts are the visible front of the space program, the FCT works around the clock to ensure the health of the crew and the smooth operation of the vehicle. Many a controller has worked on Christmas, canceled a holiday, or lain awake at night worrying about failures or wondering what might have been missed before a mission. This passion and attention to detail has allowed the ISS and the programs that preceded it—Space Shuttle, Skylab, and Apollo—to succeed. These are the people who step up when things do not go well.

But, as with the hidden magic of a stage crew on a theatre production, the FCT is rarely seen or heard. Most people’s exposure to the controllers is limited to what they see on NASA television: a serene-looking room full of men and women sitting in front of computer consoles, showing little difference between when the crew is asleep and when a major malfunction has occurred that threatens the crew, vehicle, or success of a mission. One way to tell things are not going as planned is when a collection of flight controllers, and potentially managers, huddle around the console of the flight director—i.e., the person responsible for keeping the whole



*The completed International Space Station with the Space Shuttle Endeavour on one end and the European Automated Transfer Vehicle on the other, as seen from the Russian Soyuz vehicle on May 23, 2011.*

mission proceeding along. This perspective provides little insight into what a controller or the flight director actually does while “on console.” Only when the movie *Apollo 13*—a film starring Tom Hanks as Jim Lovell, and one that NASA shows its newest team members as part of their training—was fresh in people’s minds could NASA point to something and say to the general public, “See, that is what we do.”

For the control room to appear so serene, a great deal of work (some of it admittedly boring) has preceded those efforts. The flight director is always there and takes the operational lead—from training each controller to training the crew, while overseeing the implementation of the plan, developing procedures, writing rules to guide the mission as directed by the ISS Program, and coordinating with the Engineering team. This includes the training team itself; i.e., the clever, if not diabolical, people who try to find the potholes in the mission and, more importantly, come up with failure scenarios that, even if not probable, get the team thinking about how to deal with the unexpected. In fact, this sort of training had prepared the team to think about using the lunar module as a lifeboat during the Apollo 13 mission.

This book will discuss how the flight directors and their teams make it all happen. With a foundation built during Project Mercury, the focus will be on the ISS and the unique challenges that the project has presented over its many years. Various aspects of operations—



This emblem was originally developed during the Apollo program to recognize the mission control team’s unique contribution to manned space flight since the Mercury program.

The sigma ( $\Sigma$ ) represents the total mission team, including flight controllers, instructors, flight design, mission planning and production specialists, facility development and support teams. The launch vector and plume represent the dynamic elements of space, the initial escape from our environment, and the thrust to explore the universe.

The orbiting star symbolizes a permanent human presence in space, conducting research, developing materials and leading the expanding utilization of the space environment. A single star is positioned over Houston, the home of the United States human spaceflight operations. At the top of the emblem, the Moon and Mars represent NASA’s mission to lead the nation’s permanent journey out of low Earth orbit.

The Mercury, Gemini, Apollo, Skylab, Shuttle and ISS programs are represented in the legacy ring on the bottom border, commemorating programs for which we have operated in space. On the upper border is the wording “Res Gesta Per Excellentiam” — “Achieve through Excellence” — which is the standard for our work. It represents an individual’s commitment to a belief, to craftsmanship, and to perseverance, qualities required to continue the exploration of space and the quest for the stars.

The white stars in the background represent the four original principles of the Mission Operations team: discipline, morale, toughness, and competence.

The comet represents those individuals who have given their lives for space exploration, while the seventeen blue stars represent our fallen astronauts, to whom the flight controllers dedicate their commitment to excellence. These symbols serve as a reminder of the real human cost and risks inherent to space flight and the ultimate responsibility the Mission Operations team bears in facing those risks.

**Figure 1.** The current Flight Operations Directorate emblem with an explanation as to its meaning.

from training, to planning a mission, to executing a spacewalk or, as happens, responding to a failure—are discussed in these chapters. Several chapters also describe the technical aspects of the systems to help the reader understand the challenges faced by the flight director and his or her team.

The FCT has always consisted of highly dedicated and proud people, from NASA's first flight director, Christopher Kraft Jr. and his team, Apollo 13 Flight Director Gene Kranz, and Shuttle Flight Director

Milt Heflin, to the people who sit in Mission Control today. Books by Kraft (2001), Kranz (2000), and Houston and Heflin (2015) provide additional details on the early days of flight control from the beginning of NASA through the Space Shuttle era. Those men created the Houston FCT, making it up as they went but continually learning to make things better as ever-more-challenging and complicated missions were performed. Two important items that every flight controller holds dear—the mission patch and the foundations of flight control—were developed

in the early days and, as with flight control itself, have adapted over the years. These two symbols reflect the pride and philosophy that has shaped the teams over the past 50-plus years.

As with the individual teams, mission operations has its own patch, which is rich in symbolism and history. As operations changed, so did the patch. In 2014, the Flight Crew Operations Directorate and Missions Operations Directorate were merged into the Flight Operations Directorate. Figures 1 and 2 show the current patch, its meaning, and its evolution.



**Figure 2.** As with the FCT, which has proven to be flexible and adaptable over time, the operations patch has also evolved over the years. Artist Robert T. McCall designed the initial patch in 1973. The Saturn V rocket was moved to the background and a shuttle launch was added to the center of the patch when that program began. In 2004, Mike Okuda updated the emblem to include the ISS Program, and the number of stars was increased to 17 to represent the US astronauts whose lives were lost. Program symbols were made more generic to reflect the ever-growing family of crewed missions. When the Astronaut Office merged with the Flight Operations Directorate in 2014, elements of the astronaut logo (i.e., the three contrails with a circle) were incorporated. Top row, left to right: 1973, 1983, 1988. Second row, left to right: 2004, 2012, 2014.

The foundations of flight control were born out of the ashes of failure. Shortly after the Apollo 1 fire in 1967 that killed three astronauts on the launch pad, Flight Director Gene Kranz told his team that henceforth they would need to be “tough” and “competent” to ensure such an accident would not happen again.

*“From this day forward, Flight Control will be known by two words: ‘Tough’ and ‘Competent.’ Tough means we are forever accountable for what we do or what we fail to do. We will never again compromise our responsibilities. Every time we walk into Mission Control we will know what we stand for;*

*“Competent means we will never take anything for granted. We will never be found short in our knowledge and in our skills. Mission Control will be perfect.”*

Gene Kranz (2000)

Out of this grew what is called the Foundations of Mission Control. The majority of flight controllers have this on their wall or desk, or have committed it to memory. This is the creed to which the team literally lives by every second of the day. The current version is shown below. This “tough” and “competent” stance was exhibited during the Apollo 13 mission whenever everyone gave their all to save the crew, and it has continued. Although Kranz is not sure whether he ever really uttered “failure is not an option” during the mission, it applied then and has been the mantra repeated throughout the FCT ever since.

## ***Foundations of Flight Operations***

### ***1. To instill within ourselves these qualities essential to professional excellence***

***Discipline...***Being able to follow as well as to lead, knowing that we must master ourselves before we can master our task.

***Competence...***There being no substitute for total preparation and complete dedication, for flight will not tolerate the careless or indifferent.

***Confidence...***Believing in ourselves as well as others, knowing that we must master fear and hesitation before we can succeed.

***Responsibility...***Realizing that it cannot be shifted to others, for it belongs to each of us; we must answer for what we do or fail to do.

***Toughness...***Taking a stand when we must; and to try again and again, even if it means following a more difficult path.

***Teamwork...***Respecting and using the abilities of others, realizing that we work toward a common goal, for success depends upon the efforts of all.

***Vigilance...***Being always attentive to the dangers of flight; never accepting success as a substitute for rigor in everything we do.

### ***2. To always be aware that, suddenly and unexpectedly, we may find ourselves in a role where our performance has ultimate consequences.***

### ***3. To recognize that the greatest error is not to have tried and failed, but that, in the trying, we do not give it our best effort.***

## ***The Foundations of Mission Control***

NASA is not unique in having a Mission Control. The others, either in another country or staffed by a private company, were inspired by the Mercury control center built by Kraft. These control centers share the same approach and mentalities, but with the influences of different cultures. Although the space station is international in scope, this book focuses on the US systems. High-level interfaces are discussed so that the reader can get a good understanding of the vehicle and operations; however, NASA defers to the experts among its partner organizations to tell their own story—e.g., the nice summary of the European Columbus module in Uhlig, Nitsch, and Kehr (2010), and the story of the Automated Transfer Vehicle by Castel and Novelli (2015). Each partner has its own control team, as shown in Table 1. The call signs are important since the flight directors and their teams change personnel throughout the day.

The job of flight control is to ensure the mission goes as smoothly and successfully as possible. The whole purpose of the space station is to conduct research that cannot be done on the Earth as well as developing the capabilities to return to the moon and go to Mars. NASA’s job is to facilitate the research getting done, again as with the stage crew ensuring a theatre production executes smoothly. This means ensuring the systems are working properly, and minimizing the impact (usually in the form of available crew time) when systems encounter problems. Although not

**Table 1.** All Control Centers that Operate the ISS, or Visiting Vehicles that Support the Space Station

Location	Call sign	Function
Houston, Texas	Mission Control Center – Houston (MCC-H) or Houston; also MCC-CST	United States On-orbit Segment (USOS) or control of the Boeing Company’s CST-100 (Starliner) crewed vehicle
Korolev, Russia	Mission Control Center – Moscow (MCC-M) or Moscow <sup>1</sup>	Russian Segment
Tsukuba, Japan	Tsukuba	Japanese Experiment Module elements and H-II Transfer Vehicle
Oberpfaffenhofen, Germany	Munich <sup>2,3</sup> or Columbus Control Center	European laboratory module
Toulouse, France	Automated Transfer Vehicle Control Center [retired from service]	European Automated Transfer Vehicle cargo vehicle operations
St. Hubert, Canada	Montreal	Remote Multipurpose Support Room for USOS Robotics
Dulles, Virginia	Mission Control Center – Dulles (MCC-D)	Orbital ATK “Cygnus” cargo vehicle
Hawthorne, California	Mission Control Center – SpaceX (MCC-X)	Space Exploration Technologies Corporation (SpaceX) “Dragon” crew and cargo vehicles
Huntsville	Huntsville	Payloads Operations and Integration Center

<sup>1</sup> Even though the control center is located in Korolev, which was kept secret in the days of the Soviet Union, it is called Moscow.

<sup>2</sup> Although the control center is located in this small suburb of Munich, the control center is always referred to as Munich.

<sup>3</sup> The European Space Agency has various payload support centers around Europe that interface with Munich.

experts in research operations, the FCT needs to understand what research is being performed, and how it is being performed. For example, if an experiment requires a microgravity environment as free from perturbations as possible, the operations team needs to ensure thrusters are not firing or that a visiting vehicle is not about to dock. The FCT works closely with the control centers that lead the research, and strives to maximize its ability to

complete tasks. Several other books discuss utilization in greater detail, including a book by Harm & Ruttley (2012). If the FCT is successful, the ground-breaking research is all the public hears about, which is the case for other national laboratories or outposts such as Los Alamos National Laboratory or the Amundsen-Scott South Pole Station.

## The Road to the International Space Station

### A Brief History of the ISS

Much has been written about the genesis of the ISS and its embryonic form, Space Station Freedom. However, the story really goes much further back and will not be elaborated on here. Considerably more detail can be found in such references as Catchpole (2008). A space station was always a goal early on at NASA, especially among the German team, led by Wernher von Braun, that came to America after World War II and developed NASA’s rocket technology. Landing on the moon became the priority once the Kennedy administration perceived it as an area in the space race that the US could win. The Soviets launched various space stations throughout the 1970s, including the first and culminating in the Mir complex in the 1980s. As soon as the moon landing was achieved, NASA scientists, including von Braun, began pushing for a space station. The result was Skylab—the first US station. Skylab was a great start for the US program, but it was literally assembled from spare parts out of the canceled Apollo program.

During the 1980s, as the Space Shuttle Program began to take off, quite literally. The push again grew for the US to create a space station. President Ronald Reagan eventually approved Space Station Freedom in 1984 with an \$8 billion budget; however, the program continued to fumble as the costs of the project escalated. The design was repeatedly

changed. With costs again projected to greatly exceed the budget, President Clinton ordered a rescale of the platform in 1993 with the requirement to keep the project under a \$2.1 billion annual cap. As a result, NASA developed three options that were called, in true NASA fashion, options A, B, and C. Option A was basically a restructuring of the Space Station Freedom modules. This option had a crew of about five that spent 1-month intervals on orbit. Option B was larger and could allow two shuttle orbiters to dock simultaneously. However, it would only have a human presence during shuttle missions with the science payloads operating untended in between. Although producing a capable station, this option required a large number of launches. Finally, Option C was thrown together from “spare” parts of the Space Shuttle Program and Space Station Freedom Program, including using the Columbia orbiter as a permanent module. This would get the program going quickly and more cheaply, but it did not really support a good platform down the road. Option C was essentially a modern Skylab option. All three options, however, did call for a strong international cooperation, including the European and Japanese space programs. In fact, the first two options even included using Soyuz spacecraft for the crew’s emergency return vehicles. Option A was selected and the project was now called ISS Alpha. The plan called for the first element to be launched in 1997, with “assembly complete” status slated for 2002.

## What was the Space Shuttle?

The term Space Transportation System referred to the entire program, which included the Space Shuttle, the mobile transportation launch pad, and even the assembly buildings. The Space Shuttle consisted of the external tank, which contained the liquid propellant, solid rocket boosters, and winged orbiter that launched like a rocket but landed like an airplane. The orbiter contained the crew in a pressurized area and an unpressurized payload bay. The fleet was composed of five orbiters, two of which (Challenger and Columbia) were destroyed during launch and reentry, respectively, resulting in the loss of 14 astronauts. Although not strictly correct, the terms shuttle and orbiter are used interchangeably.

At the same time, the world was undergoing a marked change. In particular, 1991 saw the collapse of the Soviet Union. In late 1993, it was announced that Russia would be full partners in the ISS project. This decision was made as much out of engineering necessity as political reality, but it has proven to be a robust partnership that has enabled the ISS Program to be a success. However, it presented some interesting challenges, which were to be expected when essentially splicing together two different space stations. Even basic infrastructure such as power was different, as every American traveler has experienced when trying to plug an American electrical device into a foreign socket. Even the planned orbit around the Earth was adjusted to accommodate the Russian rockets, which had less lifting capability than the Space Shuttle.

Because of this history, the ISS is separated into two segments—US and Russian. The United States On-orbit Segment (USOS) includes

all the non-Russian partners, most notably the European Space Agency (ESA) module, the Japanese modules operated by Japan Aerospace Exploration Agency (JAXA), and the Canadian robotic systems operated jointly between NASA and the Canadian Space Agency (CSA). The remainder is the Russian Segment. Although different countries built the various modules of the USOS, NASA integrated them all from the beginning; therefore, the modules all have the same look and feel (e.g., use the same base power standard).

The assembly sequence was laid out in three phases. Phase one was to be the learning interval. To make the project work, Russia and the US would have to learn how to cooperate in order to merge two very different programs. During this interval, US astronauts would spend time on the Russian space station Mir, and several cosmonauts would fly on the Space Shuttle. Due to the Iran Nonproliferation Amendments Act (2005), NASA could not pay for the



astronauts to be housed on Mir as Russia had done with other countries. The shuttle would help ferry up much-needed supplies in exchange for letting US astronauts gain station living experience. Simply docking the American orbiter to the Mir space station was an engineering and political feat in itself since neither the vehicles nor the programs were designed for such activities. Although automated supply ships, called Progress, serviced Mir, their capacity was nowhere near that of the shuttle. Seven US astronauts stayed aboard Mir from 1995 to 1998 for a combined on-orbit time of more than 30 months.

In the second phase, the ISS would be constructed up to a minimal set of components that would make it a self-supporting scientific outpost. To help jump-start the program, the Russians would provide the first two modules that would anchor the station by providing living quarters, power, life support, propulsion (to keep the station from falling back to the Earth), and attitude control (to keep the vehicle in the proper orientation). This phase ended with the addition of the US airlock, which provided redundant extravehicular activity (EVA), or spacewalk, capability. At this point, the ISS would consist of living quarters, docking ports, propulsion and control modules, power-generating solar arrays, and airlocks that allowed for spacewalks that were critical for repair and further assembly. This would be a self-sufficient mini-station.

Phase 3 would see the ISS evolve to “core complete.” Although more

modules were planned beyond core completion (e.g., the habitation module), this phase represented a truly complete station that would include three science modules: the US laboratory, ESA Columbus astrophysics module, and the Japanese modules with an External Exposure Facility. Initially, the ISS crews consisted of three people. When the advanced US life support system was activated in 2009, the standard crew size increased to six. The ISS will be able to routinely support a crew of seven. It is anticipated the permanent crew will reach this number upon completion of the US Commercial Crew Program.

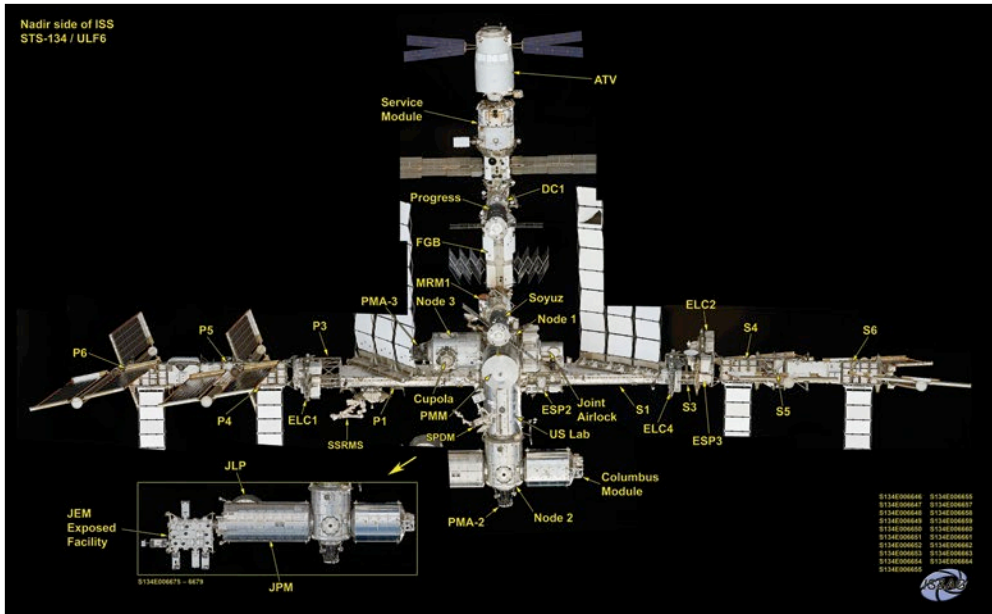
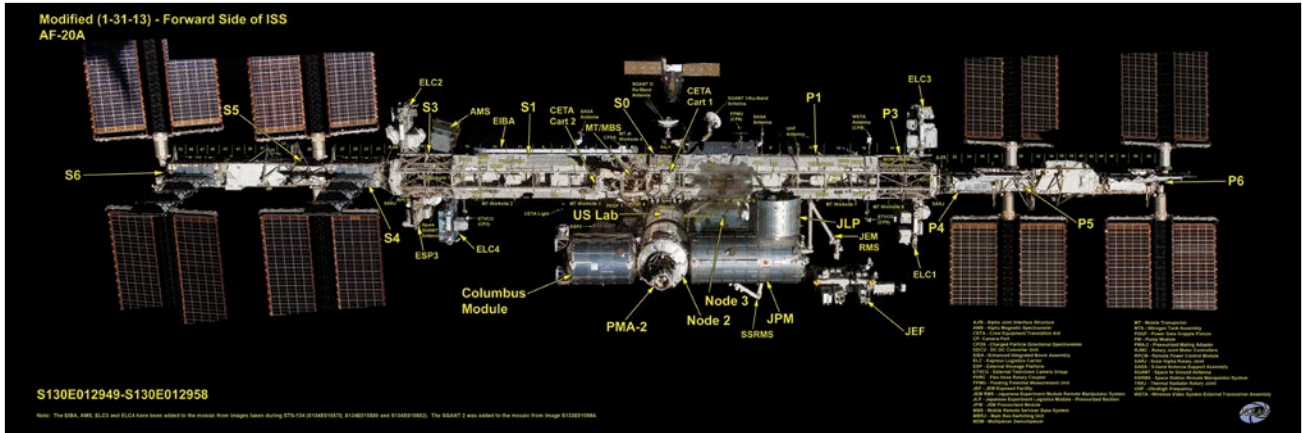
The Program Office, located at Johnson Space Center in Houston, Texas, manages the USOS. Run by the program manager, the Program Office is responsible for all aspects of the program under NASA direction. A number of divisions under the program manager oversee every aspect of the vehicle integration and operations, including engineering support, software development, external integration, planning and safety, and mission assurance. The chief scientist and the ISS Research Integration Office are tasked with maximizing the research, often referred to as utilization, on the space station. Also under the ISS Program Office is Mission Operations Support. This is performed by the Flight Operations Directorate and the flight control team that executes the real-time operation of the vehicle. Note that while each international partner and its FCT is responsible for its systems, NASA is responsible

for integration and all safety aspects of the space station. The Space Shuttle was managed out of a separate Space Shuttle Program Office.

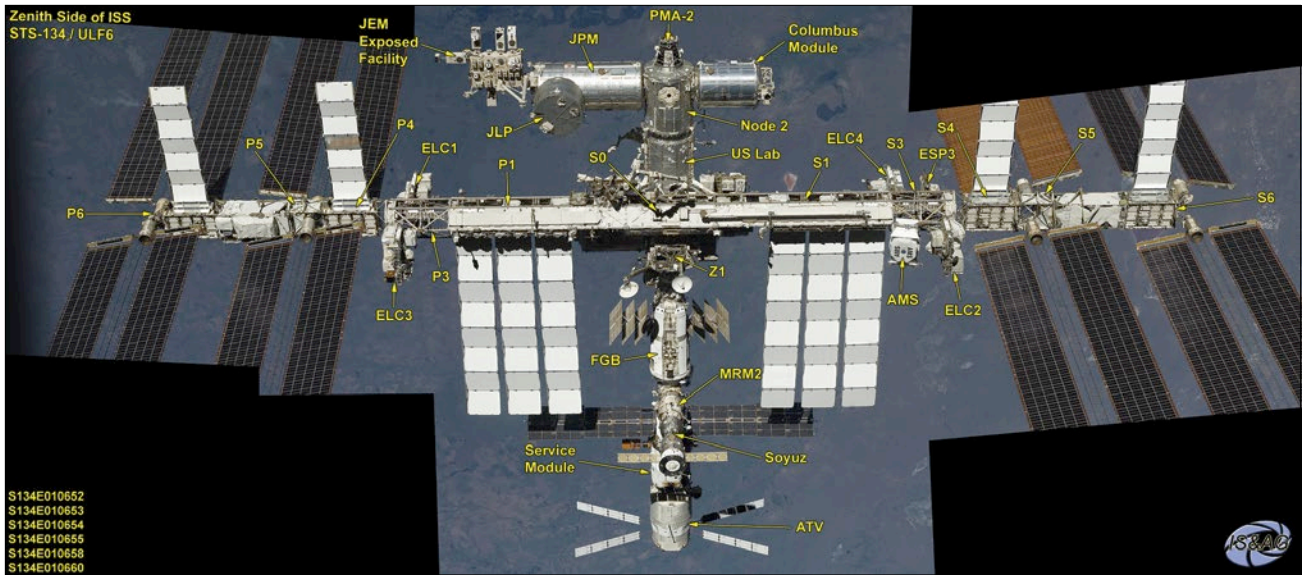
### ***Getting to Know the International Space Station***

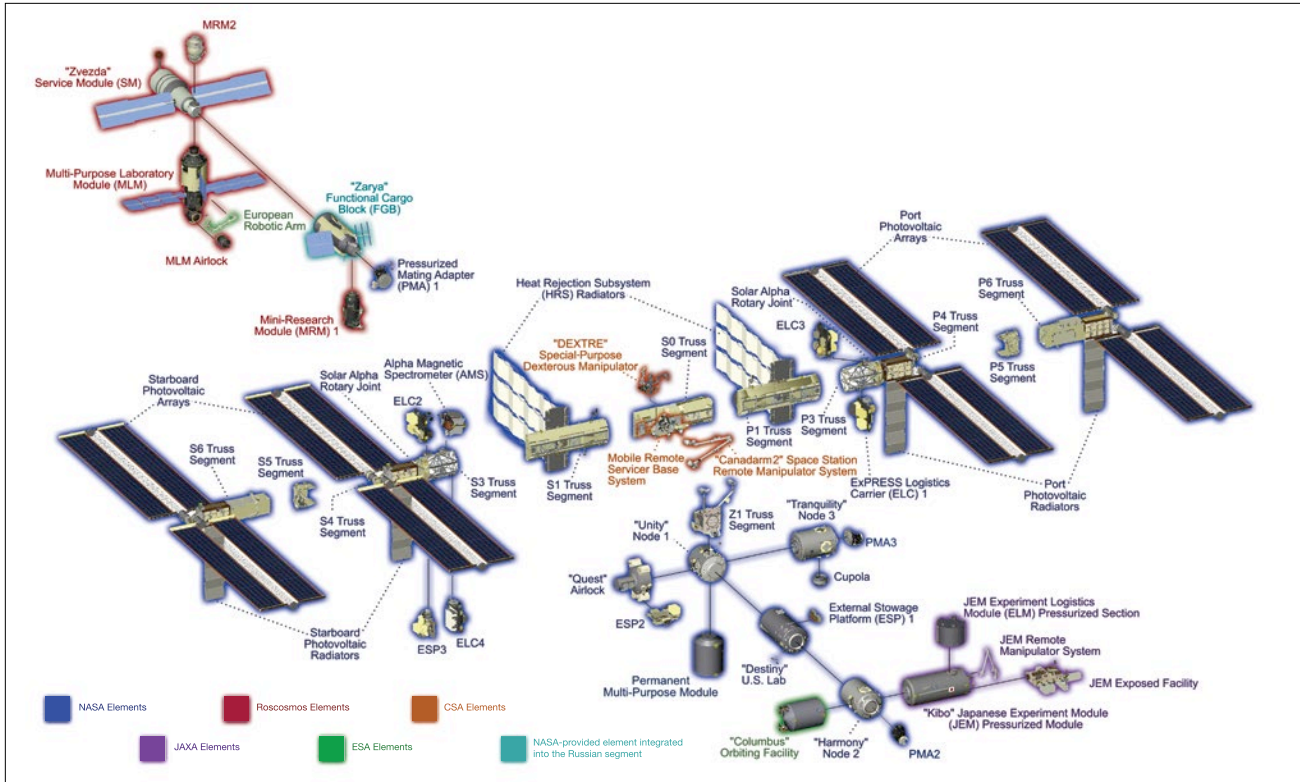
The fully assembled ISS is shown in Figure 3, with each element indicated. Although there is no true up, down, left, or right in space, a system is required to ensure everyone—crew and ground—are talking consistently. Therefore, as with a seagoing ship, the direction of motion is referred to as forward, which makes the opposite end the aft. In Figure 3, the Pressurized Mating Adapter number 2 (PMA-2) module is at the front of the station and is generally the nose pointing in the direction of flight most of the time. Facing forward (i.e., sitting on PMA-2 and looking forward) means the port side is on the left and starboard is on the right. Unlike a ship on the water, the ISS is exposed to additional directions in space—i.e., up and down. When the ISS is orbiting forward around the Earth, the direction pointing down toward the Earth is called nadir and the direction away is the zenith. More details are provided in Chapter 8.

Each module or segment of the ISS has a functional name such as Node 2, Laboratory, S0 truss, or Service Module, for example. The FCT uses these names on all its operations and clearly indicates the function of that element. For example, Node indicates a pressurized module that serves as a hub for other modules to be attached. The Integrated Truss



**Figure 3.** Composite image of the fully assembled ISS with key elements noted. (Top) View from the front-looking aft. (Middle) View from below (i.e., nadir) looking up at the ISS. (Bottom) View from above, looking down on the ISS. Orientation of the ISS is with respect to normal attitude, which is discussed further in Chapter 8. These images were compiled from dozens of photographs taken during the fly-around of the Space Shuttle Endeavour after it undocked and flew around the ISS in May 2011 during one of the last missions to the outpost. This picture also shows the European Automated Transfer Vehicle, the Russian Progress, and the Russian Soyuz spacecraft that transports the crew to and from the space station. The components are defined in Table 2.





**Figure 4.** Components of the ISS color coded by contributing country.

Segment is numbered by section and whether it is located on the port or starboard side of the ISS. Thus, S4 is the fourth truss segment on the starboard side, whereas P6 indicates the sixth element on the port side. To complicate matters, the P6 solar arrays were temporarily located on the zenith side of the ISS in 2000 until P6 was relocated to its final position in 2007. Additionally, the S2 and P2 truss segments were cut from the design during the transition from Space Station Freedom; however, the other truss segments were not renumbered. These technical names were defined early in the design and are found in every technical document used on

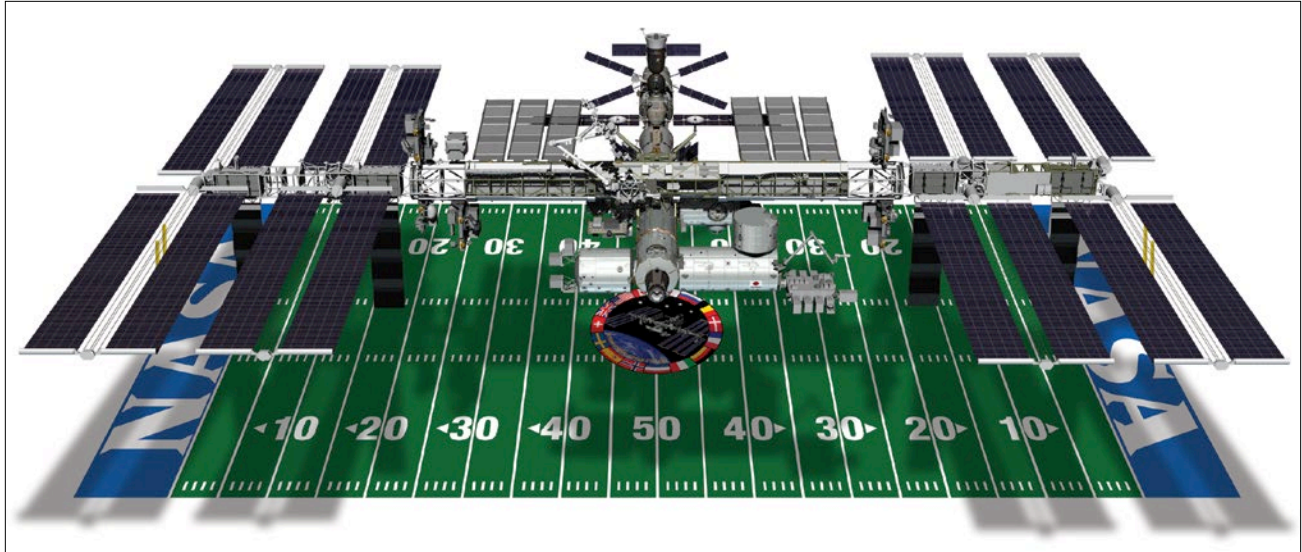
the program. Later, countries named their pressurized modules with more user-friendly names, which are used in public discourse. For example, the Laboratory module is also known as Destiny and the European Attached Pressurized Module became the Columbus module. The technical names for the segments will be used throughout this book.

Figure 4 shows a graphic of all the ISS elements and which country operates them.

The ISS is the largest vehicle ever flown in space. Figure 5 compares the assembled station to a football field for scale.

### **Assembly Sequence**

Since the ISS was too big to launch on any one rocket, it was constructed through 31 missions and, in fact, is still growing. The assembly sequence underwent many changes during development and execution. Sometimes, changes were dictated by delays. For example, when the next module was not quite ready to install, a logistics flight might have been added to take up crew supplies or smaller pieces of hardware. In another case, the launches of the Japanese and European modules were accelerated to ensure their installation on the ISS prior to the Space Shuttle retirement.



**Figure 5.** Size comparison of the ISS to a US football field. The following statistics provide additional information to offer a sense of scale.

- **Size:** 51 m (167.3 ft) from front to back (PMA2 to Service Module) and 109 m (375.5 ft) from one tip of the truss to the other. That is equivalent to the length of an American football field including the end zones (a football field measures 110 m [360 ft] in length). The ISS is almost four times as large as the Russian space station Mir and about five times as large as Skylab, the first US space station.
- **Power Generation:** Eight solar arrays on the US Segment are capable of producing a total of 84 kilowatts of solar power. The solar array wingspan (73 m [240 ft]) is longer than that of a Boeing 777-200/300 model, which is 65 m (212 ft). The total ISS solar array surface area is nearly 4,050 m<sup>2</sup> (1 acre) in size. Thirteen km (8 miles) of wire connect the electrical power system.
- **Mass:** 419,400 kg (924,700 lbs), the equivalent of more than 320 automobiles.
- **Pressurized Volume:** 916 m<sup>3</sup> (32,333 ft<sup>3</sup>), or equal to that of a Boeing 747.
- **Habitable Volume:** 388 m<sup>3</sup> (13,696 ft<sup>3</sup>), roughly the same living space as a 158 m<sup>2</sup> (1,700 ft<sup>2</sup>) house that has 2.5 m (8 ft) walls.

During the assembly phase, some missions were purely logistical in nature, bringing up equipment, supplies for the crew (e.g., food and water), or research payloads. Russia transports supplies to the ISS using its unmanned autonomous Progress vehicle. On 12 shuttle flights, the orbiter transported temporary Multi-Purpose Logistics Modules (MPLMs) containing approximately 4,500 kg (~10,000 lbs) of materials. The MPLM would ride up in the cargo bay of the Space Shuttle. After the shuttle docked, the robotic arm would take the MPLM out of the cargo hold and berth it to the ISS where

the astronauts could then exchange cargo. Before the shuttle left, the MPLM would be stowed in the cargo bay. It was later realized it would be of significant benefit to leave one of the MPLMs permanently on the ISS. One MPLM, nicknamed Leonardo, was retrofitted with additional debris shielding for a continuous life in space. Conceptually designed to act as a storage closet for the ISS, Leonardo was renamed as the Permanent Multipurpose Module (PMM) and installed on the space station in 2011. NASA and the international partners also had their own autonomous cargo vehicles. These included the ESA

Automated Transfer Vehicle, the Japanese H-II Transfer Vehicle, and the American commercial vehicles Dragon and Cygnus.

Later, when the ISS Program needed to ensure two berthing ports for cargo vehicles and two docking ports of the new US crewed vehicles, the PMM was moved from its position on the nadir side of Node 1 to the forward side of Node 3 in 2015. In 2016, the Bigelow Expandable Activity Module was installed on the aft side of the Node 3 module as part of a demonstration of such technologies. Several other modules are planned for the Russian Segment.

Each assembly mission flown by the Space Shuttle generally had two designations. First was the mission designation. For shuttle flights, this would be the Space Transportation System (STS) number such as STS-88, which indicated the 88th shuttle mission. Every ISS assembly mission would then have an assembly identification consisting of the numerical position in the planned sequence followed by the country of origin. US missions were denoted with an “A,” whereas “R” indicated Russian launches. Thus, the first US assembly mission is commonly noted as STS-88/ISS-2A, indicating it was the second American flight. One exception was the launch of the Functional Cargo Block, which was funded by the US but built, launched, and operated by Russia. This mission was designated 1 A/R, where the “A/R” indicates the joint nature of it. Sometimes, flights were added to the original plan. These were denoted by a decimal number such as 12A.1. When the order of flights were changed, as happened following the Columbia accident, the sequence was not renumbered. For example, flight 10A was moved after 13A.1. Table 2 lists all the assembly missions through 2016, plus several planned ones for future Russian modules. Note that assembly also required a number of EVAs. Those that occurred during a shuttle mission were simply numbered 1, 2, 3, etc. during that mission. Stage EVAs—those that occurred outside of shuttle flights—were numbered sequentially (1, 2, 3, etc.), with the prefix of R or US for Russian or USOS, respectively. As of 2017, there had been more than

80 USOS and Russian Segment EVAs to assemble and maintain the space station. More details can be found in Chapters 17 through 19.

Crews (which generally consist of three people) to the ISS are called expeditions, and are also known as increments. Since the first, Expedition 1, was launched to the ISS in 2000, the station has been continuously inhabited. The first crew flew to the ISS on board a Soyuz but came home on the Space Shuttle Discovery, which also delivered the second expedition crew to the ISS on STS-102/ISS-5A.1. During early ISS operations, most increment crews flew to and from the ISS on shuttle flights as shuttle-rotating expedition crew members, or “ShRECs.” Separate crews visited the ISS to rotate the Soyuz rescue vehicles when they reached their 6-month on-orbit expiration date. After the loss of Columbia orbiter and her crew in 2003, Increments 7 through 10 consisted of only two crew members—one Russian and one American—who flew to and from the ISS on the Russian Soyuz. Since then, most crew members have flown on the Soyuz. In 2009, the ISS was sufficiently mature to support six crew members permanently. Until the Commercial Crew Program provides crew rotation services, all crews rotate to and from the ISS in the three-crew Soyuz. The Soyuz stays docked at the Russian Segment for the duration of the expedition in case an emergency forces the crew to evacuate. Half of the expedition crew members are Russian cosmonauts and the other half are made up of NASA and international partner astronauts,

whereas the position of commander is rotated between the cosmonauts and astronauts. Crews consist of personnel from multiple countries and were selected, especially in the early days, to ensure that there would be at least one American and one Russian on the ISS at all times. Astronauts from ESA, CSA, and JAXA now routinely fly to the outpost and have also served as commanders. The other crew members on an expedition are referred to as flight engineers, designated generically as FE 1, FE 2, etc. These designations are used so that generic planning can occur even prior to a crew being selected or if crew members are swapped for whatever reason.

The ISS changed considerably, and sometimes dramatically, through the construction phase of the assembly process. Operational products such as flight rules (described below) and procedures executed by the crew or ground differed as well, depending on hardware and software capabilities or available modules that changed after a given shuttle assembly mission. Thus, the increment was also subdivided into stages, one stage beginning at the launch of a shuttle flight and lasting until the next launch. All operations products such as procedures referenced this stage.

A list of all the assembly missions is found in Table 2. Generally, construction occurred by attaching new modules and segments of the truss. However, modules or structures sometimes had to be moved from a temporary position to a final installation location. For example, P6 was the first set of USOS solar

**Table 2.** Listing of all Flights Assembling the ISS

ISS Assembly ID	Launch Date	Element	Public Name, if applicable (English Translation)	Launch Vehicle ID
1A/R	November 20, 1998	Functional Cargo Block (FGB in Russian)	Zarya ("Dawn" as in dawning, new)	Proton
2A	December 4, 1998	Node-1, PMA-1, and PMA-2	Unity (Node-1)	STS-88
2A.1	May 27, 1999	Integrated Cargo Carrier (ICC) for supplies		STS-96
2A.2a	May 19, 2000	ICC for supplies		STS-101
1R	July 12, 2000	Service Module	Zvezda ("Star")	Proton
2A.2b	September 8, 2000	ICC for supplies		STS-106
3A	October 11, 2000	Z1 Truss and PMA-3		STS-92
4A	November 30, 2000	P6 Truss		STS-97
5A	February 7, 2001	US Laboratory	Destiny	STS-98
5A.1	March 8, 2001	MPLM External Stowage Platform (ESP)-1	Leonardo	STS-102
6A	April 19, 2001	MPLM Canadarm2	Raffaello	STS-100
7A	July 12, 2001	USOS Joint Airlock	Quest	STS-104
7A.1	August 10, 2001	MPLM	Leonardo	STS-105
4R	September 15, 2001	RS Docking Compartment-1 (DC-1) & Airlock	Pirs ("Pier")	Soyuz-U/Progress
UF-1	December 5, 2001	MPLM	Raffaello	STS-108
8A	April 8, 2002	S0 Truss, Mobile Transporter		STS-110
UF-2	June 5, 2002	MPLM Mobile remote servicer Base System (MBS)	Leonardo	STS-111
9A	October 7, 2002	S1 Truss		STS-112
11A	November 23, 2002	P1 Truss		STS-113
LF-1	July 26, 2005	MPLM MPLM ESP-2	Raffaello	STS-114
ULF-1.1	July 4, 2006	MPLM	Leonardo	STS-121
12A	September 9, 2006	P3/P4 Truss		STS-115
12A.1	December 9, 2006	P5 Truss		STS-116
13A	June 8, 2007	S3/S4 Truss		STS-117
13A.1	August 8, 2007	S5 Truss and MPLM ESP -3		STS-118
10A	October 23, 2007	Node 2	Harmony	STS-120
1E	February 7, 2008	European Laboratory	Columbus	STS-122
1J/A	March 11, 2008	Special Purpose Dexterous Manipulator (or Dextre) Japanese Experiment Logistics Module Pressurized Section (also known as the Japanese Experiment Logistics Module - Pressurized Section)		STS-123
1J	May 31, 2008	Japanese Pressurized Module (Japanese Experiment Module [JEM]-PM) JEM Robotic Arm (JEM-RMS)	Kibo ("Hope")	STS-124

(continued next page)

**Table 2.** (continued)

ISS Assembly ID	Launch Date	Element	Public Name, if applicable (English Translation)	Launch Vehicle ID
ULF-2	November 14, 2008	MPLM	Leonardo	STS-126
15A	March 15, 2009	S6 Truss		STS-119
2J/A	July 15, 2009	Japanese Exposed Facility (JEM-EF)		STS-127
17A	August 28, 2009	MPLM	Leonardo	STS-128
5R	November 10, 2009	Mini Research Module-2 (MRM-2)	Poisk (“Explore”)	Soyuz-U/Progress
ULF-3	November 16, 2009	Expedite the Processing of Experiments to the Space Station (EXPRESS) External Logistics Carriers (ELC 1 & 2)		STS-129
20A	February 8, 2010	Node-3 and Cupola	Tranquility (Node-3)	STS-130
19A	April 5, 2010	MPLM	Leonardo	STS-131
ULF-4	May 14, 2010	MRM-1	Rassvet (“Dawn” as in daybreak)	STS-132
ULF-5	February 24, 2011	PMM (was Leonardo) ELC-4		STS-133
ULF-6	May 16, 2011	Alpha Magnetic Spectrometer and EXPRESS Logistics Carrier 3		STS-134
ULF-7	July 8, 2011	MPLM	Raffaello	STS-135
Commercial Resupply Services-8	April 8, 2016	Bigelow Expandable Activity Module		SpaceX Falcon 9
3R	August 2018 (scheduled)	Multipurpose Laboratory Module with European Robotic Arm	Nauka (“Science”)	Proton
6R	2018 (scheduled)	Node Module	TBD	Soyuz
TBD	TBD	Science-Power Module	TBD	TBD

arrays launched in 2000 (Chapter 9). These arrays provided power for the core systems in the early phase of the ISS. Since the truss was not yet completed, and to ensure that dynamic forces such as atmospheric drag worked uniformly on the ISS, the P6 was attached to the Z1 segment at the center of the structure. Later, when the truss had been extended, the arrays were retracted, P6 relocated to the end of the main truss, and the solar arrays were redeployed (see also Chapters 9 and 18). The Pressurized

Mating Adapters (PMAs) numbers 2 and 3 that serve as docking ports have been moved multiple times. The Node 2 module was delivered to the space station on a shuttle flight and was initially installed on the port side of Node 1 because the orbiter was docked at the final installation location of Node 2 (PMA-2). After the orbiter undocked, PMA-2 was moved to the end of Node 2. The Node 2 plus PMA-2 combination was then moved from its temporary position on Node 1 to its final location

at the front of the Laboratory module via the robotic arm (Chapter 15) before the next shuttle mission. Subsequent shuttle missions docked to the PMA that attached to Node 2 on the “front” of the space station. PMA-3 was moved to the Zenith port on Node-2 in March 2017 to support a second commercial crew docking port. An excellent video that shows the full assembly sequence, including this complicated dance, can be found at: <https://archive.org/details/ISSAssemblyAnimation-2011>.



**Figure 6.** An example of a standard rack being installed in the Japanese Experiment Module. The rack is partially rotated into place on its pivot points (Chapter 3) while an astronaut works on connections behind it. To the right of the image is a fully installed rack.

Standardized racks are fundamental components of the ISS (Figure 6). These racks are carried up in US and Japanese cargo vehicles and transferred to the ISS where they fit into contoured rack bays. Some bays are outfitted with power, computer, cooling, vacuum, or ventilation systems. In this fashion, equipment can be taken to or returned from the ISS. Many of the core racks contain vital hardware such as computers and pumps, but research payloads are also supported in this fashion. Thus, for example, a rack to study combustion in space is installed into

a bay. With a few quick connections for power, computer interface, cooling, and vacuum ducts, it is ready to conduct ground-breaking research either with the astronauts' support or remotely from the ground. When its research is complete, the rack can be returned to Earth to be fitted with a new experiment. With the retirement of the Space Shuttle, several vehicles can transport racks to the ISS, but only one can return them to the Earth (Chapter 14).

Another level of modularity on the ISS is that almost all hardware can be replaced. Wherever possible, systems

consist of Orbital Replacement Units (ORUs). The ORU is designed so that if it fails—or, as happens in some cases, is upgraded—the astronauts can take out the old one and put in the new unit. This may sound obvious when designing anything, let alone a multibillion-dollar space vehicle; however, it adds complexity and is a trade against cost and engineering challenges. For example, take a pump that moves cooling fluid around. The pump contains many elements such as electronics, motors, and valves, so there is always a chance that some component may fail. However, the



pump cannot simply be pulled out because the cooling fluid will go everywhere. Therefore, valves that can be closed off to isolate the pump from the fluid must be installed. These extra valves add cost and weight, and require software to control them. Since valves can fail, they too must be replaceable. ORUs exist on the inside or outside of the ISS. External ORUs are usually stored on External Stowage Platforms (ESPs) or Expedite the Processing of Experiments to the Space Station (EXPRESS) Logistical Carriers that are mounted on the truss of the ISS.

## The Team Behind The Curtain

Flight control has been a key part of spaceflight since the first rockets left the Earth's gravity. In fact, the roots of flight control go back to aircraft tests that were conducted before the space age, such as the breaking of the sound barrier by Chuck Yeager in 1948, or the ultra-high altitude balloon flights of the 1950s (Ryan, 2003). Christopher Columbus Kraft Jr. adapted existing flight control processes for operating NASA's crewed spacecraft in the beginning days of Project Mercury in the early 1960s (Kraft 2001). Additional historical details may be found in Herd, Dempsey, and van Leeuwen (2013).

The FCT is a rather large group of console operators, support personnel, and systems engineers. A clear hierarchy starts at the flight director's console. While on console, "Flight" leads all the real-time operations. In reality, there are layers above Flight including the ISS Mission

## FLIGHT DIRECTOR AUTHORITY

- A. THE MISSION CONTROL CENTER HOUSTON (MCC-H) FLIGHT DIRECTOR OR THE MISSION CONTROL CENTER MOSCOW (MCC-M) FLIGHT DIRECTOR WILL BE IN CHARGE OF EXECUTION OF REAL-TIME STATION OPERATIONS AT ALL TIMES AS THE LEAD FLIGHT DIRECTOR. REFERENCE FLIGHT RULE {B1-10}, LEAD ROLE HANDOVER.

*The ISS crew and flight control teams must have a clear understanding at all times of who is directing the real-time station operations.*

- B. THE MISSION CONTROL CENTER-HOUSTON (MCC-H) FLIGHT DIRECTOR HAS INTEGRATION RESPONSIBILITY OF THE ON-ORBIT OPS SUMMARY (OOS), THE OOS UPDATES, SHORT TERM PLANS (STP'S), ONBOARD STP'S (OSTP'S) (IF DIFFERENT FROM THE STP'S), AND THE EXECUTE PACKAGES, SUMMARY PLANS, WEEKLY PLANS, AND DAILY PLANS (IF DIFFERENT FROM THE WEEKLY PLANS), AND OVERSIGHT OF REAL TIME OPERATIONS CONSISTENT WITH RULE {B1-9}, MCC RESPONSIBILITY

*MCC-H and MCC-M will be involved at all stages of ISS assembly and operation. The lead MCC Flight Director will always work to forge a consensus among all partner control teams both when working real time and in planning issues.*

**Figure 7.** A sample of a flight rule, in this case showing the authority of the flight director between the Mission Control Centers in Houston and Moscow.

Management Team (IMMT), which is controlled by the Program Office. Technically, the ISS Program Office owns the space station and its operation is delegated to the FCT in the Flight Operations Division. The head of the ISS Program manages the mission requirements and objectives as well as the vehicle constraints. The head of the ISS Program Office, or his or her delegate, chairs the IMMT.

Before a mission or activity, the FCT will write flight rules and a mission plan based on these objectives and constraints. Flight rules are pre-planned decisions and agreements

that have been approved by the program. They are used to guide the FCT when time is of the essence. An example is shown in Figure 7. The mission plan is not only a timeline, it is a schedule of constraints (e.g., activity B is dependent upon the successful completion of activity A). When things go well, the team follows the rules, procedures, and timeline. Where possible, likely failures are anticipated and some level of products dealing with those cases are also created. If something goes wrong, or off-nominal, the flight director will determine whether the preapproved



**Figure 8.** The main control room, FCR-1, in NASA's Mission Control Center in Houston, Texas. Flight Director Robert Dempsey (standing) leads the team as the Space Shuttle Endeavour approaches the ISS (two far-left video screens). The center screen projects a map of the Earth and the trajectory of the ISS as it orbits (top portion of screen), as well its orientation (bottom two panels of the screen). The right screen displays a history of all ground commands to the ISS as well as the status of any alarms on the ISS. Clocks for various activities are in amber along the top of the screens.

rules cover the situation and, if not, consult the IMMT, time permitting. Otherwise, he or she will act to ensure the safety of the crew and the vehicle.

The structure of the flight control room around the world, whether for probes, satellites, or missions with astronauts, is pretty much the same and has changed little over the decades. The flight director directly interfaces with, and oversees, the team in the Flight Control Room (FCR), pronounced “ficker” (Figure 8). This is the room normally seen on television during missions. The ISS flight controllers sit in FCR-1, whereas the Space Shuttle operators sat in the White FCR. Simulation training is

conducted in different control rooms. The front of the FCR usually contains large screen displays—video, Earth map, clocks—that the entire team uses to maintain “situational awareness” during the mission. An important situational awareness display showing malfunctions on the spacecraft is often displayed in the front of the room, as well. For the ISS, this is called the Caution and Warning Summary (see also Chapter 5). Various consoles that are specialized on a subset of spacecraft systems dot the room. Six systems—power, computer control, communication, attitude control, thermal control, and life support—make up the core systems, which

are required to keep the vehicle and crew alive. Additional consoles support specific tasks such as robotics, spacewalks, and timeline planning. The FCR operators may be supported by one or more additional operators in other areas of Mission Control, commonly called backrooms or formally referred to as a Multipurpose Support Room, pronounced “mipser.” Unlike other industries such as nuclear power plants, an operator is not assigned to monitor safety in real time, as the flight rules and training builds that function into the operations. Each system has its own call sign and logo, developed and displayed with a great deal of pride (see Table 3). Not listed

**Table 3.** ISS Flight Control Positions during the Evolution of the ISS. The first column lists the system, whereas the second indicates the call sign of the person who operated the listed system during the assembly phase. Backroom support is listed in column three along with the call signs. During the assembly sequence, several positions were merged into two Gemini positions during some shifts; these positions and their call signs are listed in the 4th column. The name Gemini was chosen since the core systems were merged into two positions. After the assembly of the ISS was complete, several positions were permanently combined as shown in the last column. Generally, these positions do not use backroom support, or do so only during special mission activities.

Position	Name (call sign)	Backroom Support (or Multipurpose Support Room)	Gemini Phase Name (call sign)	Current Name (call sign)
Motion Control	Attitude Determination and Control Officer (ADCO)	HAWKI†	Telemetry Information Transfer and Attitude Navigation (TITAN)	Attitude Determination and Control Officer (ADCO)
Command & Data Handling	Onboard Data Interfaces and Network (ODIN)	Resource Avionics Engineer (RAVEN)		Communications Rf Onboard Network Utilization Specialist (CRONUS)
Communications and Tracking	Communications and Tracking Officer (CATO)	STATION Radio frequency (Rf) Communications (STARCOM) Assembly Video Engineer (AVENGER)		
Electrical Power Systems	Power, Heating, Articulation, Lighting Control (PHALCON)	PHALCON: Power Resource Officer (PRO) SPARTAN: Station Power Operations Controller (SPOC)	Atmosphere Lighting Articulation Specialist (ATLAS)	Station Power, ARTiculation, Thermal ANALysis† (SPARTAN)
Environmental and Life Support Systems	Environmental Control and Life Support Systems (ECLSS)	Atmosphere/Consumables Engineer (ACE)		Environmental and Thermal Operating Systems† (ETHOS)
Thermal Control Systems	Thermal Operations and Resources (THOR)	Thermal Control (TCON)		
Structures and Mechanisms	Operations Support Officer (OSO)	OSO Support		Operations Support Officer (OSO)
Planning	Operations Planner (Ops Planner)	Long Range Planner (LRP) Resource Planning Engineer (RPE) Orbital Communications Adapter (OCA)	Operations Planner (Ops Planner)	Operations Planner (Ops Planner)
Flight Director	Flight Director (FLIGHT)		Flight Director (FLIGHT)	Flight Director (FLIGHT)
Spacecraft Communicator	Capsule Communicator (CAPCOM)		Capsule Communicator (CAPCOM)	Capsule Communicator (CAPCOM)
International Partners Liaison	Remote* Interface Officer (RIO)	Houston Support Group (HSG) Columbus Support Group (CSG) SSIPC Support Group (SSG)	Houston Support Group (HSG) Columbus Support Group (CSG) SSIPC Support Group (SSG)	Remote* Interface Officer (RIO)
On-board computer networks	PLUG-in-plan and UTILization Officer (PLUTO)	PLUTO Support (PLUTO Support)	PLUTO Support (PLUTO Support)	Plug-in-Plan and Utilization Officer (PLUTO)
Medical support	BioMedical Engineer (BME)	Crew Health Care System Hardware (CHeCS)	Crew Health Care System Hardware (CHeCS)	BioMedical Engineer (BME)
Surgeon	Surgeon (SURGEON)		Surgeon (SURGEON)	Surgeon (SURGEON)
Ground Systems and Networks	Ground Controller (GC)	Numerous support positions such voice, command and communications systems	Ground Controller (GC)	Ground Controller (GC)
Trajectory and Tracking	Trajectory OPERations Officer (TOPO)		Trajectory OPERations Officer (TOPO)	Trajector OPERations Officer (TOPO)
Pointing position of the ISS	Pointing Officer (Pointing)		Pointing Officer (Pointing)	Pointing Officer (Pointing)
Stowage tracking	Cargo Integration Officer (CIO)		Integrated Stowage Officer (ISO)	Integrated Stowage Officer (ISO)

(continued next page)

**Table 3.** (continued)

Task-Specific Positions				
Robotics	Robotics Officer (ROBO)	Mobile Servicing System – Systems (Systems) Mobile Servicing System – Task (Task)		Robotics Officer (ROBO)
Spacewalks	Extravehicular Activity (EVA)	Systems (EVA Systems) Tasks (EVA Tasks) Extravehicular Mobility Unit (EMU)		EVA
Visiting Vehicles	Visiting Vehicles Officer (VVO)	Automated Rendezvous Officer (ARO) Visiting Vehicle Dynamics (VV DYN)		Visiting Vehicles Officer (VVO)
Integration for Visiting Vehicles	Integration and Systems Engineer (ISE)			Integration and Systems Engineer (ISE)

\* Initially Russian Interface Officer until additional partners added when it was changed to Remote Interface Officer.

† SPARTAN operates the external thermal systems and ETHOS controls the internal.

†† The origin of this name is less straightforward than the other positions. The letters do not spell out words; they are actually standard mathematical symbols: Momentum (H), Attitude (A), Angular Rate (w), Kinetic Energy (K), Moment of Inertia (I)

in Table 3, but still an important part of the team, is the payload operations director who is the flight director equivalent for the science operations that are run out of the Payload Operations Integration Control Center in Huntsville, Alabama.

The FCT has evolved over the life of the ISS. Between the first element launch (1998) and the first crew (Expedition 1) taking up a permanent residence in 2000, the FCT only worked one 9-hour shift a day, Monday-Friday, to check on the systems, as limited as they were. Outside of this window, the station duty officer and flight director monitored the systems, calling in the full team when needed to support a major dynamic activity or to deal with an anomaly. With astronauts and cosmonauts on board beginning in 2000, the core team supported 24/7, 365 days a year. Two Gemini officers monitored the six core

systems to relieve burnout of the team during quiet times, typically during crew sleep or off-duty weekends. All consoles and the Multipurpose Support Room were staffed during major events such as shuttle missions or spacewalks. After assembly was completed, it was possible to reduce the number of flight controllers since systems were now fully mature and configurations changed less frequently. Several disciplines were merged in 2010, and most positions

do not have backroom support, except for major activities. On the weekends or when the crew is asleep, non-core systems personnel can go home, albeit staying on-call for problems. Flight and ground control are always on console.

Flight controllers communicate with each other via voice loops. Although the control room always appears serene and peaceful, chaos is generally reigning in the ear of an operator. Each operator wears

**As with the Space Station, Mission Control Also Evolves**

The Blue FCR was the original control room for the ISS. Before the ISS, this control room was the Special Vehicle Operations room from which single mission projects, such as the Hubble Space Telescope servicing flights or specific payload launches, would be operated. Later, the ISS team moved into the FCR-1, which was the original FCR built at Houston’s Mission Control Center in 1965. Apollo 7, Apollo-Soyuz Test Project, Skylab, some Space Shuttle missions, and the ISS have all been operated from FCR-1.

a headset that is plugged into an audio display panel. There are approximately 20 audio conference channels or “loops” on a given display, and 10 displays to choose from. Using the display, the controller can select which loops to listen to and which one loop on which to talk. Four loops are reserved as the primary channels for the astronauts and ground to communicate. These are designated as Space-to-Ground 1, 2, 3, and 4. Additional channels are described in Chapter 13. One of the first skills a controller needs to master is the ability to listen to multiple conversations simultaneously, picking out the things that affect him or her directly, hold conversations above the cacophony, and stop everything instantly when there is a call on the space-to-ground loops from the crew. To facilitate this process, the FCT uses codes and special phrases to keep discussions concise and crisp, as described in Chapter 10.

Staffed by NASA and contractor engineers (primarily from the Boeing Company), the Mission Evaluation Room (MER) also supports operations. As the primary contractor of the ISS since the early days of the program, the Boeing Company and its subcontractors designed and built the majority of the US ISS hardware. These MER personnel retain and manage valuable design specifications, manufacturing documentation, and general system knowledge that is highly beneficial for the operation of the space station. The MER supports the operations team with a structure similar to that of the FCT (i.e., a Command and Data Handling

subject matter expert that supports the Communications Rf Onboard Network Utilization Specialist flight controller). Each MER discipline has its own call sign and set of loops to communicate among themselves or the FCT. As with the controllers, the MER team has a leader called the MER manager, which is similar to the flight director. The MER manager is consulted if a question comes up during operations, such as how something worked in testing or how the software might respond in a particular configuration. If the MER does not have the information on hand, he or she will consult with the vast Boeing organization to collect and provide the data. Generally, the MER is staffed only between the hours of 9:00 a.m. - 5:00 p.m., Monday-Friday, but is supported around the clock during major activities or if an anomaly occurs. In the event of an anomaly, it is the MER’s function to gather data, ascertain the problem, and devise a fix. These activities are coordinated with the FCT throughout such investigations.

As owners of the ISS, the Program Office also has a team that supports operations on a regular basis. This team, the ISS Management Console, provides coordination with the program management, including keeping them apprised of all activities, successful or not, as well as coordinating with the management teams of the other partners.

Finally, representatives from the international partners maintain some presence in the Mission Control Center-Houston, mainly to help with

the integration of the operations from day to day. Most notable among the partners presence is that of the Russians, who maintain a small team of flight controllers, trainers, and a flight director as part of what is called the Moscow Support Group. Besides performing coordination tasks, the group can operate the Russian Segment in the event of a significant problem with the control center near Moscow. Likewise, NASA maintains a small team in Russia known as the Houston Support Group. NASA and the international partners also exchange support group personnel, though sometimes only during critical mission phases.

Flight control is different for the ISS than it was for the shuttle and earlier spacecraft. In the case of the Space Shuttle, the astronauts were responsible for most operations, and the ground followed along. Almost all commands to the vehicle were “switch throws” or other similar operations by the crew. In contrast, the vast majority of the ISS commands are sent from the ground. This allows the crew to focus more on the science payloads and less on vehicle operations. A typical day during a shuttle mission saw the FCT uplink less than 500 commands. The collective station FCTs, located all around the world, routinely send 50,000 commands per day to the ISS.

It takes several years to become a certified flight controller (see also Chapter 10). Although, generally, the team is made up of engineers—and positions and degrees are highly correlated (e.g., an electrical engineer



**Figure 9.** Control centers that affect the ISS around the world.

supports the power systems <https://www.nasa.gov/sites/default/files/atoms/files/np-2015-05-022-jsc-iss-guide-2015-update-111015-508c.pdf>, a computer scientist might support the computer systems—it is not strictly required. Math and English majors and even astronomers have been, and still are, flight controllers. Initial training provides every new person with general knowledge of spaceflight operations, the vehicle, visiting spacecraft, the NASA organization, how to work with international partners, and even how to conduct meetings. Training involves completing computer-based training, reading manuals and instruction books, and attending classroom lessons. Eventually, the student

supports simulations where the operations of the ISS are reproduced by computers and significant failures can be experienced by the team. Training in general and simulations specifically are described in more detail in Chapter 10. Once certified, flight controllers, instructors, and flight directors all must continue to perform proficiency training and evaluation to ensure they remain at peak performance levels. Flight directors are generally selected from seasoned flight controllers. As of 2017, 91 individuals have become certified NASA flight directors.

Similar structures, room layouts, training, and operations occur in the various control centers around

the world that manage the ISS (Figure 9). See also Herd, Dempsey, & Leeuwen. (2013). Joint training between the various control centers is performed for specific mission activities (e.g., activating the Columbus module, docking the European cargo vehicle). Pictures of the different control centers can be found in <https://www.nasa.gov/sites/default/files/atoms/files/np-2015-05-022-jsc-iss-guide-2015-update-111015-508c.pdf>. The control rooms of the CSA Space Operations Support Center (see also Chapter 15) and the Payload Operations Integration Center are shown in Figure 10. The American visiting vehicle control centers are displayed in Chapter 14.



Image Courtesy of the Canadian Space Agency



**Figure 10.** Other key USOS control centers. The top image is of the CSA Space Operations Support Center in St. Hubert, Quebec, which supports robotics operations. The bottom image is of the Payload Operations Integration Center in Huntsville, Alabama.

## Naming Conventions

Flight controllers and their flight director can hold whole conversations awash in acronyms or “NASA speak.” Throughout the book, we have tried to use as few acronyms as possible. Unfortunately, it is not possible to tell the story of the ISS without referencing many of the common terms. This will be explained, when used. A complete list can be found in the Appendix.

Another challenge with this topic is that it is international. Under NASA integration, all operations on the USOS are conducted in English. All procedures, labels, and even discussions with the astronauts use English. An exception to this rule are the Russians. All of their systems, flight control operations, and cosmonauts use Russian and, of course, the Cyrillic alphabet. Critical systems or emergency procedures are marked in both. The US FCT needs to be versed to some extent in Russian, since it is used when communicating with their counterparts. Thus, everything on the Russian Segment may have a Russian name, a Cyrillic acronym, an English transliteration, and an English acronym. Brackets are placed around the letters to indicate a transliteration from regular English acronym. For example, the central computer on the Russian

Segment (Table 4), which is shown in Chapter 3, interfaces with the main computer on the USOS. This book will use the English acronym.

## Book Layout

This book is comprised of two types of chapters. Ten chapters provide an overview of the key systems on the ISS. These are the computer, communications, thermal control, life support, power, structures, and motion control systems. Each one of these is critical to supporting the crew and the other systems so that the ISS can continue to operate. Additional technical detail can be found in Chamitoff and Vadali (2018). Although one would not consider them core systems, the planning, robotics, and EVA (i.e., spacewalking) functions are extremely critical to the construction and operation of the space station. These systems are therefore included in the technical chapters. These chapters provide the foundations for the remaining “Day in the Life” chapters, which detail the operations of the ISS by the FCT.

Each Day in the Life chapter focuses on a theme in the area of operations. The themes will cover the routine operations of the space station—though it might be argued that nothing is routine in space—

and the unusual or contingency operations. Change supported by flexibility and adaptability make up the reality of operating a complex vehicle in space. Chapter 2 describes the day-to-day life during the time an increment crew is on the ISS, whereas Chapter 4, The Making of a Mission, describes the process of putting together and executing major missions using a shuttle assembly flight for illustration. A specific example of change is discussed in “Brain Transplants” of the ISS (Chapter 6) where, as with terrestrial desktops, laptops, and smartphones, the software that is operating the vehicle is completely updated. Low-Earth orbit is a dangerous place for many reasons, but most notably due to a large amount of debris that, if it struck the ISS, could kill the crew. Therefore, the FCT continuously monitors this debris and occasionally maneuvers the space station out of the way, as described in Chapter 8. Training is critical, and Chapter 10 provides a small flavor of that world from the viewpoint of the team members as they simulate life and death on the station. Flight controllers have to spend a great deal of time planning for the unexpected and preparing for contingencies that, if things go well, may never be needed. Having the crew members abandon the station and come home in order to save their lives is one of

**Table 4.** Example of Russian-English Acronym Reference

Russian Name	Russian Cyrillic Acronym	Translation	English Transliteration	English Acronym
Служебный модуль центрального компьютера (Sluzhebnyy modul' tsentral'nogo komp'yutera)	ЦБМ	Service Module Central Computer	[TsVM]	SMCC



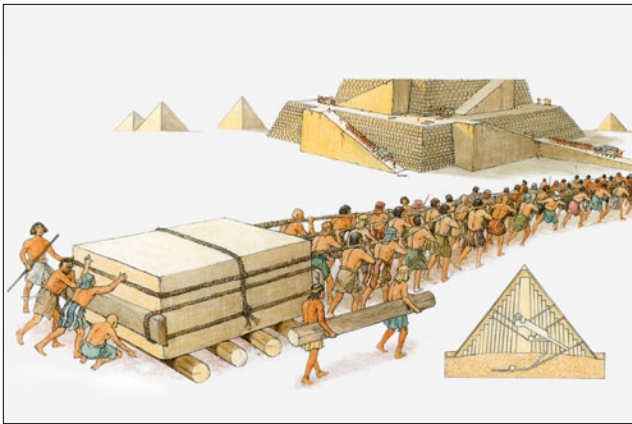
the things the ground team has to think about. If the unfortunate day ever comes, NASA will be prepared (Chapter 12). As with any remote outpost, supplies and fresh personnel have to be brought to the station and ferried home. This process, which has also evolved significantly over the lifetime of the space station, is discussed in Chapter 14, along with the continuous coming and going of these visiting vehicles. As can happen in any home or research facility on Earth, things sometimes break or need to be modified. In-Flight Maintenance (Chapter 16) discusses making these repairs—whether it be finding a leak, or fixing a stuck hatch or a broken computer. Some installations or repairs require a spacewalk, as described in Chapter 18. More serious failures also occur in space, such as when the pump that controls half of the critical cooling system on the ISS fails. In this case, all systems are affected and every team, including robotics and EVA, are involved in the recovery in what is known as an “all hands on deck” scenario. These cases are discussed in Chapter 20, “When a Major Anomalies Occur.”

Acronyms, references, and information on the authors of this book can be found in the Appendix.



# Chapter 1 **Systems:**

International Space  
Station Planning—  
A Roadmap to  
Getting It All Done



*Building both the pyramids and the International Space Station presented significant logistical challenges that required careful planning. Clockwise from upper left: the pyramids of Giza, the completed space station, Mission Control, a graphic showing the construction of the pyramids.*

**More than 4,500 years ago, Egyptian pharaoh Khufu and his architects stood upon the Giza plateau near modern-day Cairo and contemplated the building of what was at the time, and is still considered to be, one of the most immense undertakings of humankind: the building of the great pyramids of Giza.** Foremost in their minds was the scale and complexity of the task, and the organization, choreography, and supply of the vast number of architects and laborers needed to complete the job. Thus, one of the seven wonders of the ancient world was completed over a period of 20 years through careful planning and execution, as well as by establishing a reliable supply chain of food and materials.

It has been argued that the scale, size, and complexity of the International Space Station (ISS) along with the distributed international workforce of engineers, managers, technicians, and scientists is this era's equivalent to the pyramids. As a result of careful long- and short-range planning and a well-developed logistics plan, the ISS has served as a continuously occupied human outpost and research laboratory in low-Earth orbit since November 2000. Unlike the pyramids, however, the ISS has evolved significantly during and subsequent to its construction, adapting to catastrophe (e.g., Space Shuttle Columbia) or political goals.

This chapter focuses on both long- and short-range planning. Any activity that occurs on the

ISS—whether it be running a science experiment or performing a spacewalk—takes years of planning and preparation. The ISS Program office first lays out high-level priorities and plans years in advance. When will a supply mission launch? Who will the crew members be? Will the astronauts stay on orbit for 6 months or a year? When will spacewalks be needed? More and more details are worked out as the time for a mission approaches. A robust planning process also allows for change, whether it is due to a failure or problem, or simply a change in priorities. During any given week, hundreds of activities are performed, each with its own resource needs (e.g., power, sample bags), constraints (e.g., needing the same

physical space), or crew availability (e.g., a given crew member trained for a particular task). The focus of this chapter is on the increment, typically a 6-month stay for a crew, where multiple events—spacewalks, supply missions, scientific research—take place, whereas Chapter 4 details the planning process for a specific mission. The long- and short-range planning process will be discussed along with the specific products and groups involved. With assembly of the ISS complete, the ultimate goal in planning is to maximize the amount of research that will be performed by a well-resourced crew.

## Long-Range Planning— Building Up to the Increment

Years in advance, ISS Program personnel lay out a high-level manifest. The focus of this manifest is primarily supply—i.e., when will cargo vehicles be available to transport critical food, water, oxygen, fuel, spare parts, clothing, and scientific payloads. Since supply vehicles can, and have, failed to reach the station (e.g., the Russian Progress and the American Orbital and SpaceX launch failures in 2014 and 2015), the program tries to allocate extras wherever possible. Another factor in this planning may be the availability of hardware. For example, an experiment might be planned for a particular increment; however, if the hardware runs into unexpected issues during development, the schedule will slip, perhaps to an increment that does not have the necessary upmass capability or enough crew time available due to higher priorities. Approximately 2 years prior to a given increment, ISS Program personnel, with input from the operations team, begin detailed planning by establishing priorities for a given increment. These priorities

are documented in an increment-unique requirements document called the Increment Definition and Requirements Document (IDRD). The IDRD contains specific categorical requirements for areas such as medical operations, science operations, photography, ISS maintenance, and equipment manifests. Unique to each increment, the IDRD is used in conjunction with a more-generic requirements document called the Generic Groundrules, Requirements, and Constraints (GGR&C), which applies to all increments. The GGR&C provides general requirements for all activities. For example, it dictates that the astronauts should normally plan for at least 8.5 hours of sleep per day, 2 hours of pre-sleep to unwind and prepare for bed, and 1.5 hours of post-sleep to wake up, perform hygiene duties, and prepare for the day. The execution planning teams use this document as the primary guidance for developing the plans that will be described in this chapter.

The primary focus of the IDRD development phase is to define requirements for the increment (e.g., number of spacewalks or reboosts needed to maintain vehicle altitude). Since there is always more to do than available time or resources allow, the IDRD provides priorities to aid in decision making during execution, should trades need to be made. The IDRD also details the availability and expected use of key consumables that the ISS uses over the course of the increment. Managing consumables is also a complex process. Consumables include those needed for life support as well as for the spacecraft or experiments. Program personnel estimate how much oxygen, water, fuel, etc. are needed. This can be a tricky calculation because individual crew members consume oxygen and water at different rates. Even fuel

can be difficult to manage because the altitude of the ISS is affected by a number of parameters, not the least being the irregular activity on the surface of the sun. Once the needs are identified, program personnel evaluate the available upmass—i.e., which launch vehicles have available space. Something big or heavy being launched on one vehicle means less available upmass for other items. Program personnel put forth considerable effort analyzing the stowage configuration throughout the increment based on the visiting vehicle traffic plan along with the expected trash generation and disposal plan. Development of the research plan—specifically, which experiments will fly, and when those experiments will fly—occurs in parallel with this planning. This intricate planning can be especially challenging when an experiment, new hardware, or even a replacement part is not ready as scheduled, due to unexpected challenges.

Program requirements determine how much time is available for specific activities. Per the GGR&C, astronauts are required to have 8.5 hours a day allocated for sleep. Four hours a day are set aside for post-sleep and pre-sleep, 3 hours for meals, and approximately 2.5 hours for exercising. Daily planning conferences are scheduled twice a day to allow the ground and crew time to tag up on the activities about to be performed or completed. Time for other tag-ups are also allocated to discuss stowage and transfer, especially prior to and during cargo resupply missions or in preparation for spacewalks. Since the astronauts are typically on the ISS for 6 months, unlike a short Space Shuttle mission, they have a half day on Saturdays to perform weekly housecleaning, and a full day on Sundays to do whatever they please. Several major holidays

per increment are also set aside for the crew to have time off from work. The remaining time is divided between maintenance or assembly activities or “utilization”—the catchphrase for all scientific research. Construction or developmental tasks dominated crew time during the assembly time frame, with little time available for utilization. Utilization time was so short in the early days of the ISS Program that astronauts would often do volunteer science on Saturdays. However, this practice can lead to overly tired crews and, possibly, burnout. By about 2013, 30 hours a week was being carved out for utilization, which is expected to reach more than 70 hours a week around 2018 when the new US commercial crewed vehicles, which can carry four astronauts, become available.

Crews are assigned to an increment at about the same time that the IDR development kicks off. Early in the program, especially during the assembly phase, crew selection was often based on planned activities. For example, astronauts who were skilled in robotics could be assigned to increments where a great deal of robotic work might be needed. Similar assignments could occur for increments heavy in spacewalks. This proved challenging to the flight control team, astronauts, and trainers as schedules frequently shifted, often due to shuttle mission delays. As the ISS evolves, and as planners gain more experience with the ever-changing nature of ISS operations, crews are being provided with generic skill-based training such as preparation for any type of operation. For example, a crew might be trained to perform a spacewalk and change out a generic box instead of learning the specifics of a particular unit. Electrical connectors for all boxes are similar, thus specific instructions can

## Now where did I put that?

A lot of equipment and supplies go to and return from the ISS. Experiments and food, for example, go up; research specimens and broken parts needing repair come down. Imagine keeping track of everything in your house over many years. Now, add in the complexity that occurs when the residents change every 6 months. Every bit of space on the ISS is used for something—e.g., if a system component or an experiment is not in a spot, that spot is probably being used for stowage. ISS Program personnel try to position as much spare parts, food, and water to keep operations going for as long as possible since supply rockets can, and have, failed to deliver precious supplies. Managing where and how to store all the supplies and equipment required to keep the ISS going is literally a full-time job. That job belongs to the Inventory Stowage Officers (ISOs) in Houston, along with their counterparts in Tsukuba, Munich, Huntsville, and Moscow. Most items have a barcode that can be read by a laser device. These barcodes are similar to those found on products in terrestrial stores or radio frequency identification chips, and are tracked in a database known as the Inventory Management System. The ISO works with the rest of the flight control team to build stowage notes for crew activities. These notes tell crew members where to find the tools and equipment they will need, and where everything goes when they are done. Gathering and stowing tools takes a significant amount of time and is built into the time allocation of each activity. The ISO works out how to unpack and put away cargo brought up to the ISS in arriving vehicles, how to pack whatever needs to be returned to Earth, and where to temporarily store items that will be thrown away. Each week, the ISO tags up with the crew during a short conference to make sure all the instructions that the crew members received for stowage management that week were clear, to answer any questions they may have, and to start the planning process for the next week.

Even with barcodes and the ISO team on the ground, items get lost or misplaced. When this happens, the flight control team will actually create a “wanted” poster, alerting crew members to keep their eyes open for the missing hardware. Although most missing items are small, even large ones can disappear, as was the case of a pump module that measured 72.9 x 45.0 x 45.7 cm (28.7 x 17.7 x 18.0 in.). That pump module was eventually found tucked behind a rack.

be provided just prior to a specific extravehicular activity (EVA).

As the increment gets closer, placeholder events documented in the IDR (e.g., EVAs) evolve into specific tasks such as repairs or experiment payload deploy. The final IDR is published 1 month before

the start of the increment. At this point, planning enters the execution phase with the Operations Planner (OPS PLAN) leading the detailed schedule development.

Planning by the flight control team begins in parallel with the final phases of IDR development. This allows

planners to evaluate the set of proposed increment requirements for feasibility before the final requirements are approved while allowing planners to begin developing their databases of activities. Increment planning, performed by the flight control planning team, is broken into pre-increment planning and execute planning. The pre-increment planning phase begins 1 year prior to the increment start and ends at increment start—3 weeks (I-3 weeks). As described in detail below, the primary products generated during this phase are the Increment Overview, On-orbit Operations Summary (OOS), and the Execute Planning Groundrules and Constraints (Gr&C).

Three weeks prior to start of the increment, the planners begin what is called the “execute” phase. The primary products of the execute phase are the Monthly Calendar, Weekly Lookahead Plan (WLP), Short Term Plan (STP), Onboard Short Term Plan (OSTP), and Daily Execute Package. Although this process is orderly, significant change is occurring through the entire process as ISS Program priorities change. Problems such as broken hardware or a supply mission delay are the main drivers for these changes. Thus, replanning is an ongoing process.

## Increment Planning

The International Execute Planning Team (IEPT), led by the lead operations planner resident at NASA Johnson Space Center, develops the pre-increment products. Planning representatives from each international partner (see Introduction)—NASA, Russia, Europe, and Japan—comprise the IEPT. The Payloads Operations and Integration Center organizes research in the United States,

**Table 1.** Dates are referenced to the start of the increment (I) and the time. I-12 indicates 12 months before the start of the increment.

Increment Overview	Increment-Specific Groundrules & Constraints	On-orbit Summary
Draft: I-12 months	Draft development occurs ~I-8 through I-4 months	Draft development occurs ~I-8 through I-4 months
Preliminary: I-6 months	Preliminary: I-4 months	Preliminary: I-4 months
Final: I-1 month	Final: I-1 month	Final: I-1 month

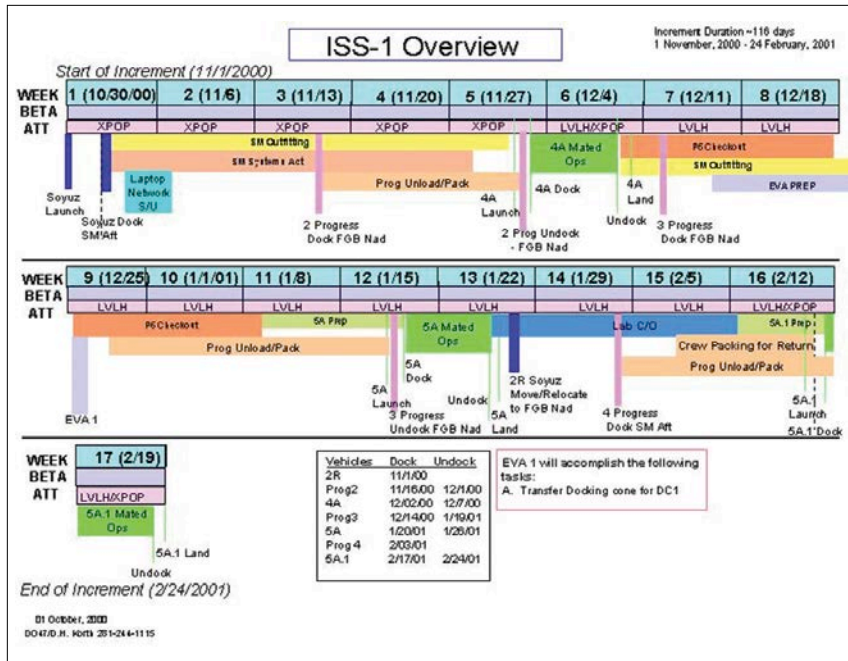
whereas the lead mission control center for each partner coordinates its respective research activities. The IEPT members conduct regular conferences, routinely exchange planning data according to a predefined schedule, and participate in two face-to-face meetings for pre-increment planning product finalization. During the execute planning phase, IEPT meetings (telecons) are conducted 3 days a week to facilitate WLP and STP development and replanning.

A key task during pre-increment planning is to evaluate the feasibility of the program requirements. At this stage of the process, planners begin translating program requirements into activities and assigning these activities to periods of time during the increment to determine whether sufficient resources (e.g., crew time) are available and whether defined activity constraints (e.g., microgravity periods, sufficient day/night cycles, etc.) can be satisfied. Detailed procedures and time estimates are generally not available at this stage; however, the operations team has done enough analysis to have a reasonable estimate on how long each activity will take. If an activity is particularly complex, the operations team may conduct a dry run in the mock-up facility to improve the time estimate. Eventually, as the time of executing the activity gets closer, the procedure will be verified and the final time estimate will be available. If the activity has been performed

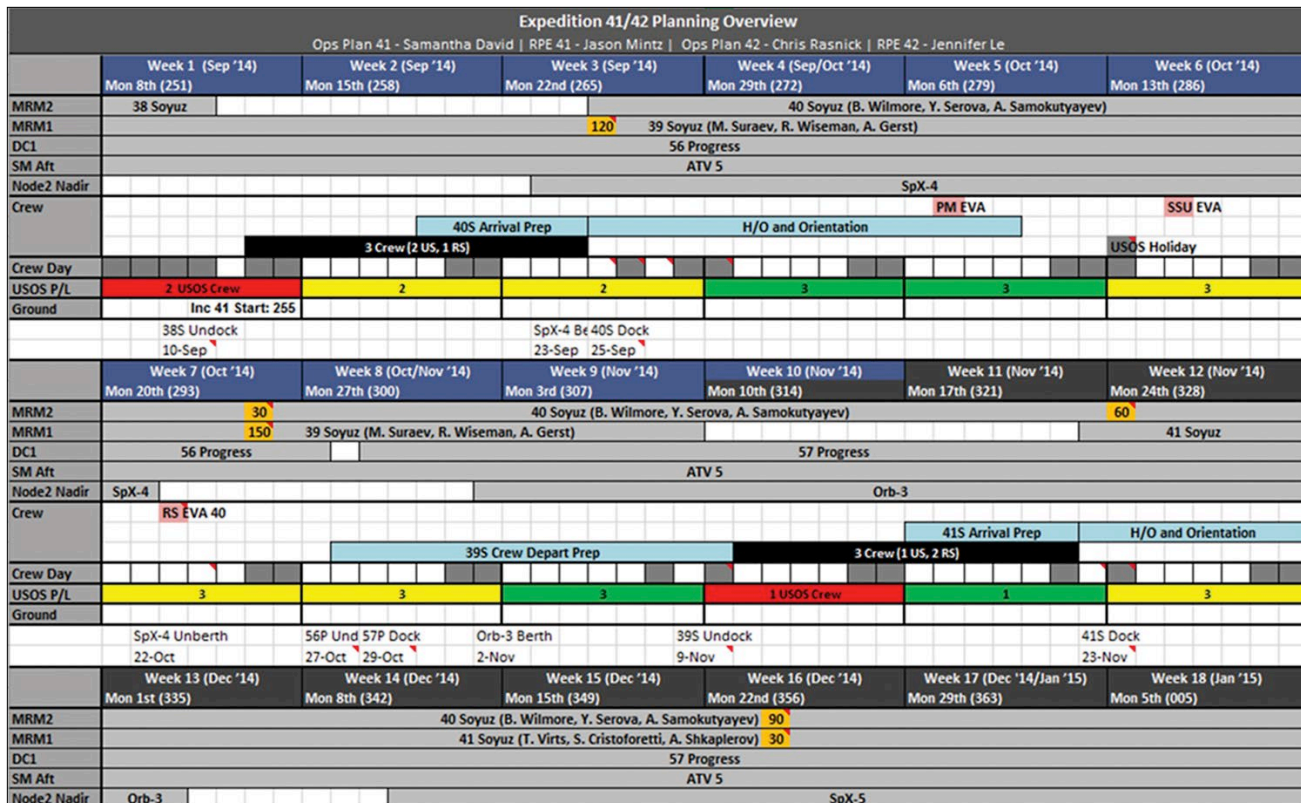
previously or is suitably similar to another activity, the time can be better estimated. However, individual crew members can take a different amount of time to perform the same activity, depending on background or previous experience in space. The IEPT develops the primary products of this phase—the Increment Overview, OOS, and Gr&C—according to a predefined schedule (Table 1).

The Increment Overview (Figure 1) is the official planning document until 1 month prior to beginning of the increment when the final OOS provides the information for the final stages of planning. The document contains a summary of key increment operations such as spacewalks and illustrated vehicle traffic to and from the ISS. Vehicle traffic includes the Soyuz flights that bring the new crew as well as the cargo resupply missions. Further, the Increment Overview provides estimates of crew time for research utilization. For example, the crew might have an expected amount of 30 to 40 crew hours available in one week for experiments, whereas another week might contain a spacewalk and may only have 5 to 10 hours available.

The OOS as shown in Figure 2 is a high-level plan, organized by day, spanning the entire increment that addresses crew time usage and indicates other major operations (e.g., visiting vehicle arrivals/ departures, EVAs, significant non-crew operations, etc.). The intent

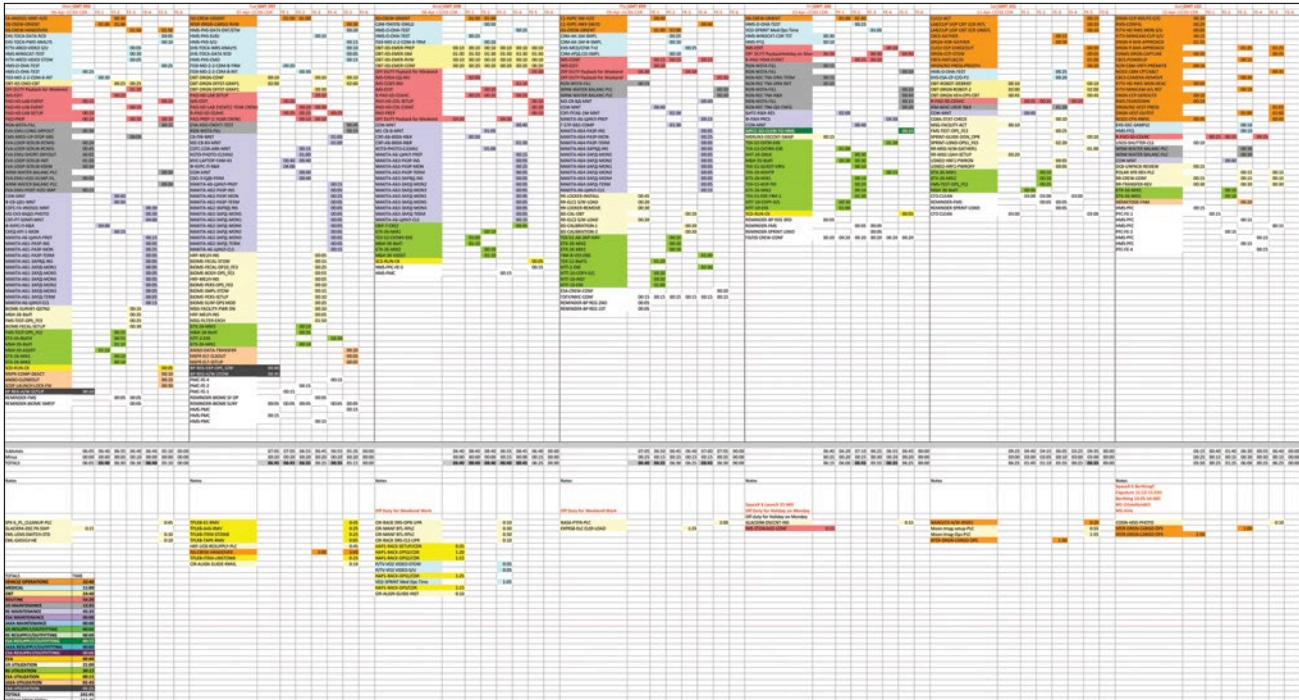


of the OOS is to provide an initial implementation of the increment requirements, as identified in the IDRD, GGR&C, and program directives, and establish the feasibility of satisfying the science commitments for the increment. Conversely, the OOS also serves to point out “hot spot” areas during the increment where crew time availability will be constrained or where other operations may not be possible to execute unless priorities are adjusted, often through detailed negotiation with the partners. Specifically, the OOS contains the following information: Greenwich Mean Time date, activity, activity location, comments, Russian ground site on-range times, solar beta angle (see Chapter 7), and increment day.



**Figure 1.** Increment Overviews from the first expedition (top) and one from Expedition 41/42, 15 years later (bottom). In the top figure, the dates are placed across the top. Major vehicle attitude is listed, such as X-Perpendicular Out of Plane (XPOP) and local vertical/local horizontal (LVLH) as well as beta angle (see Chapter 7). Major activities such as a Soyuz launch are also shown below on the given date. Activities tend to be high level—Service Module (SM) outfitting, laboratory checkout (Lab C/O), and EVA preparation. In the bottom image, the data are essentially the same, though neither beta angle nor attitude are listed since the ISS now generally flies the same attitude.





**Figure 2.** Several weeks of the OOS from Increment 43, which was the first 1-year increment to the ISS beginning in March 2015. Activities and their durations are color coded to indicate the major category in which they belong (e.g., vehicle operations, EVA, scientific research), thus facilitating crew resource analysis and optimization. The operations planning team, international partners, and ISS Program office analyze the distribution and allocation of crew time in the OOS time frame prior to execution, primarily to assess the feasibility of IDR requirements implementation. Task color coding persists through all phases of flight (pre-increment, in-flight, and post-execution reports are analyzed) so that the teams can measure progress and apply appropriate lessons learned to future planning cycles.

It does not contain the specific time in which an activity is scheduled on the given day.

The OOS is developed over the course of several months, culminating in a final version that the IEPT members and ISS Program management review and approve at I-1 months. Planning takes into account resource availabilities (primarily crew time and, on occasion, power, etc.), trajectory data (i.e., solar beta angle, Russian ground site availability), and other defined constraints. Upon approval, the final OOS shows the plan for accomplishing increment objectives along with a detailed activity database. It should be noted that mission planners use the results from the development of the Increment Overview and the Final OOS for

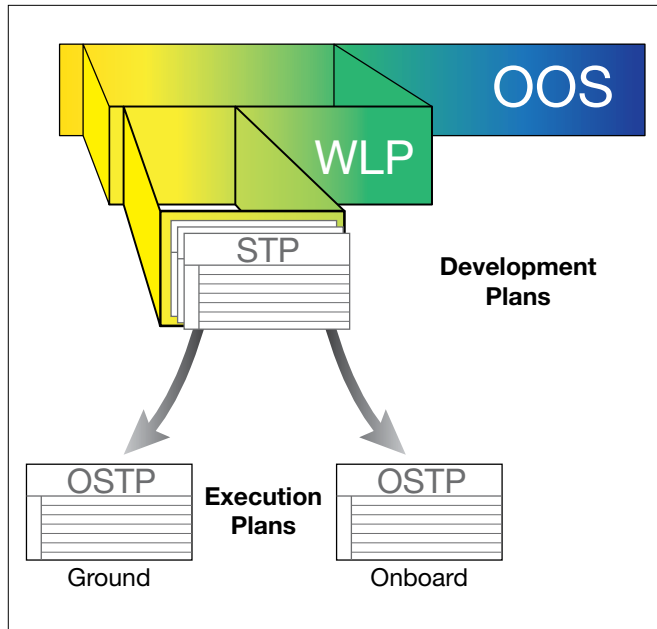
updating and developing the IDR. This ensures the requirements going into the increment execution phase are aligned with the feasibility of implementing these requirements.

Execute planning describes the phase of operations from publication of the Final OOS through the end of the increment. Execute planning deals with development of plans for execution by crew and ground control teams based on the OOS (Figure 2). The long-range planning (LRP) team develops these execution planning products. The OPS PLAN team is responsible for executing and replanning while on console in the Mission Control Center (MCC) in Houston. Both teams require significant interfaces with disciplines that are both internal and external to

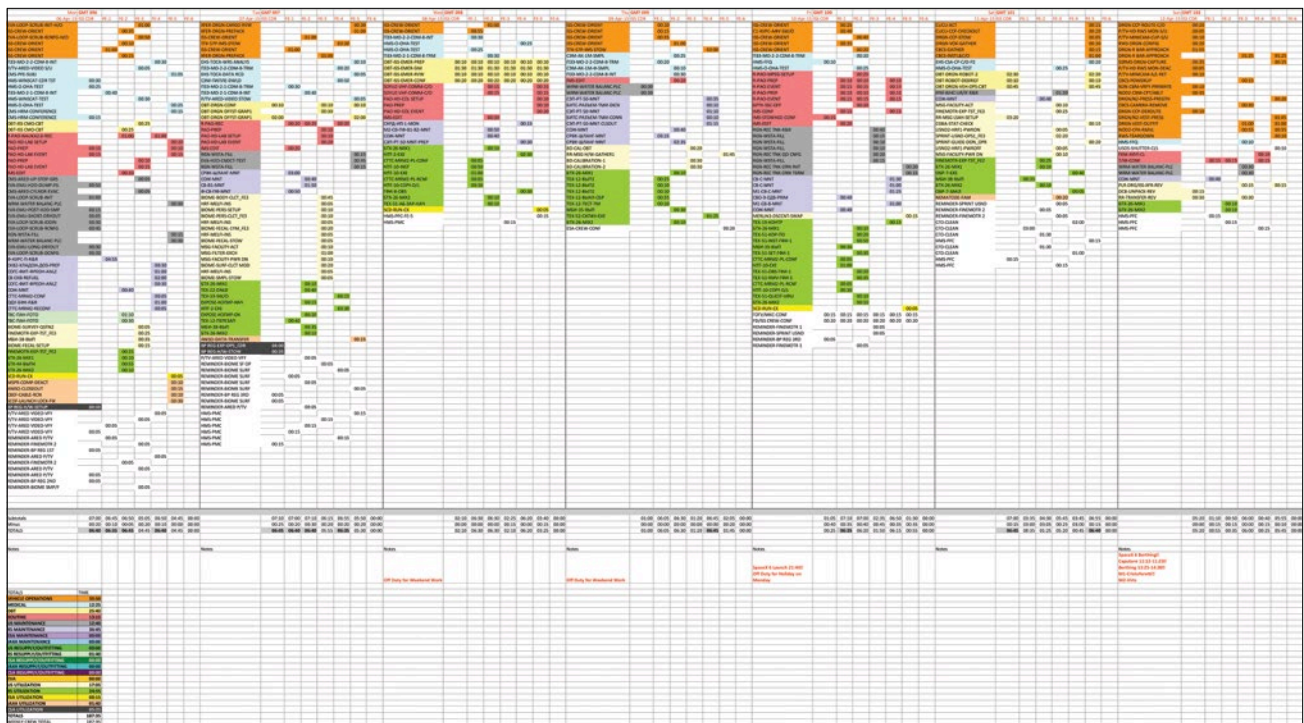
Johnson Space Center to generate and execute effective ISS plans.

The LRP team generates WLPs and STPs using the OOS, ISS Program directives, current vehicle operations status, and unique operations constraints. The OPS PLAN team takes these timelines and generates executable plans, or versions of the STP, that the crew and ground teams will use to perform daily ISS tasks. The OSTP is the new “executable” version of the STP that is used by the crew and ground teams. At this point, activities are detailed enough that specific procedure steps, stowage items, and key notes directing the crew in how to perform the task have already been established. The OPS PLAN team further prepares supplementary materials (i.e., Daily Execute Package) to aid in daily plan

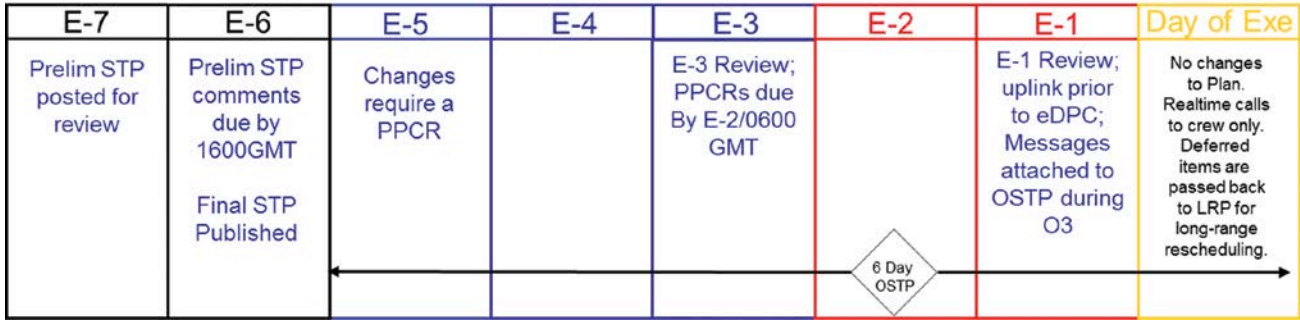
execution. This package includes data such as the current state of the ISS (e.g., which computers are configured as primary, safe angles to park the solar arrays in the event of a loss of attitude control [see Chapters 5 and 7, respectively]), questions for the crew from the previous day's operations, answers to crew questions from the previous day, summaries of key operations for that day, and a list of the key flight control personnel from the various ISS control centers. Any changes to the plans are coordinated with the LRP team and are reflected in updates to the WLPs, STPs, and OSTPs. The overall WLP, STP, and OSTP development timeline is depicted in Figure 3.



**Figure 3.** Plan Development Flow showing how the OOS feeds into ever-more-detailed products such as the WLP, STP, and OSTP.



**Figure 4.** WLP—list by day of crew operations and other major objectives for 1 week of ISS operations. Activity durations are listed under the crew member who will be performing the activity, but the specific time during the day is not yet defined. All activities are given standard reference codes that the crew and flight controllers understand. For example, EVA-PROC-CONF means the EVA team will have a procedure review conference with the crew on Thursday, though the specific time is not yet scheduled. Russian activities are shown in Cyrillic. As with the OOS, activities and their durations are color coded to indicate to which major category they belong (e.g., vehicle operations, EVA, scientific research). In the WLP phase, the team's analysis of crew resource allocation focuses more on optimization and measuring progress, and serves as a tool for navigating planning "tradespace." For example, if an unplanned EVA is required to repair a pump module that has failed, the team must quickly understand how many hours are needed to perform a spacewalk as well as the hours of scientific research, periodic maintenance, or cargo transfer that must be rescheduled to make room for the contingency EVA.



**Figure 5.** The development cycle of the STP and OSTP generation cycle starting 7 days prior to the Day of Execution (Day of Exe) with each day indicated as Execution, or E, minus the day. All Planning Product Change Requests (PPCRs) are due 3 days prior to execution. The final plan is uplinked to the crew the day before execution and reviewed during the evening Daily Planning Conference (eDPC) on the planning or orbit 3 (O3) shift.

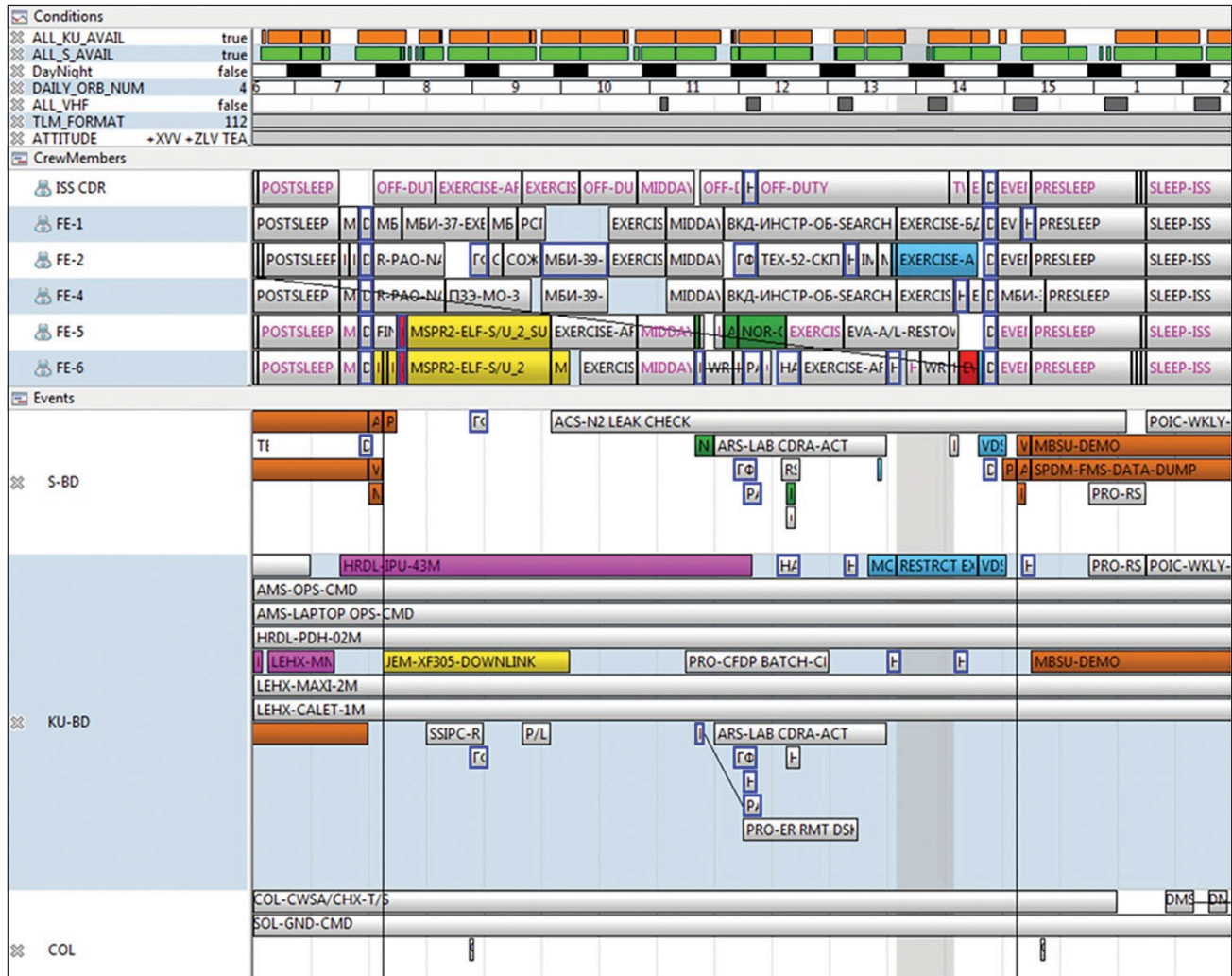
The beginning of the execution plan development process begins 2 weeks prior to a week of plan execution with the development of the WLP. The LRP team begins WLP development by revisiting a particular week from the OOS to update the planned information based on recent changes encountered during the execution of the increment since the OOS was published.

Figure 4 shows the WLP plan, which has a detailed list of crew activities assigned to each crew member for each day of a particular week in the increment, in addition to any significant non-crew operations on each day. The operations team or payload organization provides the crew time requirements for each crew activity planned and summarizes to ensure compliance with GGR&C crew time constraints (e.g., 6.5 hours of schedulable crew time each crew workday). The WLP plan looks similar to the OOS, but it contains the information for only a single week of the increment, as can be seen in Figure 4. Up to this point in the planning process, managers have planned and assigned all tasks to specific days or weeks of the increment, with an emphasis on crew time availability. Now, planners look at the details of the planned activities and begin the process of creating a

timeline or schedule of events. Other constraints and resources, such as communications coverage, equipment use, day/night cycles, data bandwidth availability, etc., are considered at this phase of the planning process, in addition to crew time constraints. Details of unique activity constraints are contained in an activity database maintained by the planners as well as in a Gr&C document created by the international planning team at the start of the increment. For example, it might be the case that astronauts cannot eat or perform certain types of exercise within a certain amount of time prior to a medical procedure, such as a blood draw. Operations that were not completed earlier in the increment due to problems or a lack of time may, depending on priorities, get pushed to a later week. Although the program previously baselined the requirements for the increment, changes are inevitable. During the increment, the ISS Mission Management Team (see Introduction) approves the updates, which the planners also incorporate during this time frame. Once drafted and before implementation, the IEPT, flight controllers, and program managers conduct a final review to ensure everything fits within the requirements and needs of the program, as well as within the

capability of the crew, ground team, and vehicle. This level of attention to detail is required since crew time is extremely precious and any wasted time can impact the success of the program goals. The Final WLP then serves as a type of contract between the flight team and the ISS Program regarding what will happen for that particular week.

The STP is a timeline derived directly from the WLP and consists of all activities to be performed on the ISS for a particular day. Figure 5 shows the development timeline for an STP covering 1 day of ISS operations to take place 7 days in the future. As mentioned, an STP is created (following the template outlined in Figure 5) for each day represented in the Final WLP. The STP is presented as a graphical timeline of crew and ground activities for a particular day (Figure 6) to be used as an output from a common planning system shared by all ISS planning communities. The format includes horizontal bands for individual crew member activities, trajectory information (day/night, Tracking Data Relay Satellites for communications coverage, Russian Ground Sites, Daily Orbit Number, spacecraft attitude), systems and payload commanding, automated systems and payload operations, and ground

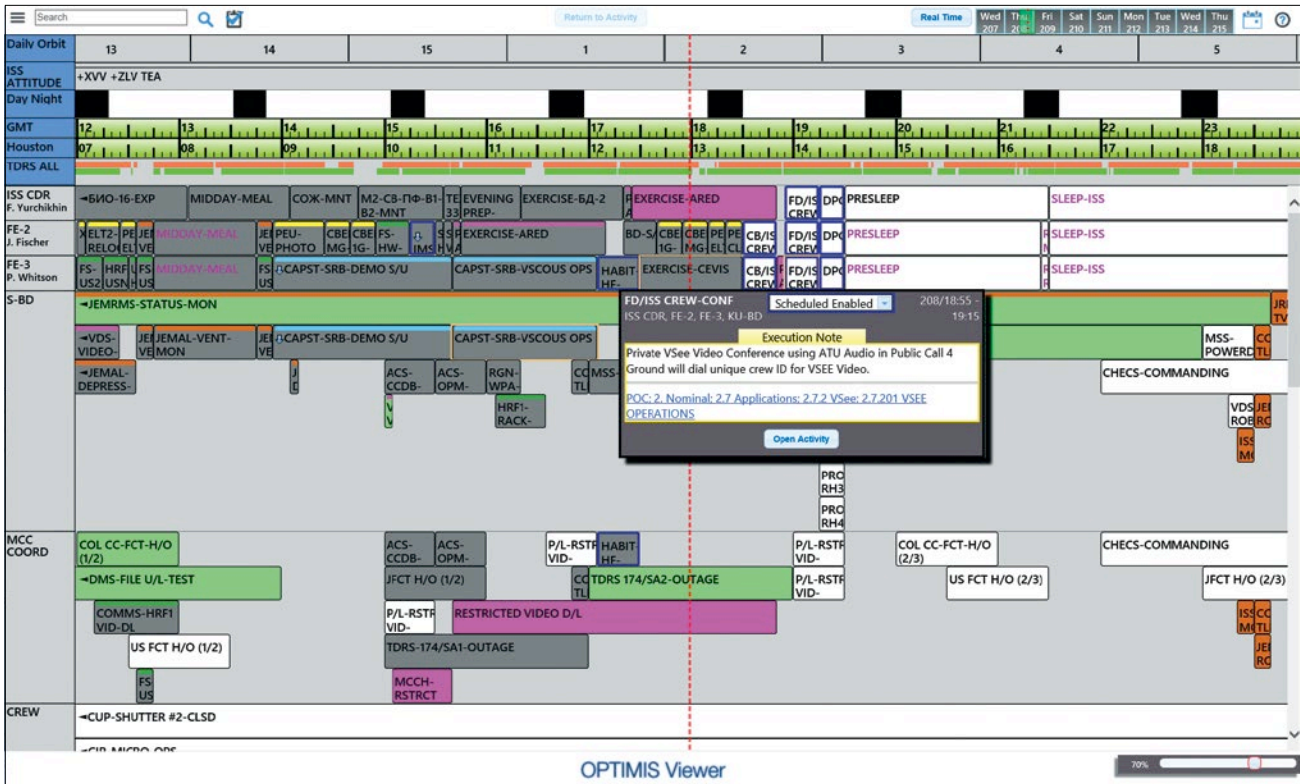


**Figure 6.** Graphic depiction of the STP timeline generated from the WLP for a particular day of the week. The top bands show when S-band or Ku communications coverage is available, when the day/night cycles occur, the station attitude, and even the configuration of the planned telemetry link to the ground. Crew member activities (e.g., CDR for Commander or FE1 for Flight Engineer 1), shown near the top, detail their specific activities. Other display bands indicate which activities are using the S- or Ku-band systems, and required coordination with the MCC or, in this example, what the Columbus (COL) flight control team members are doing.

coordination activities. The STP is the baseline plan, and it takes precedence over the Final WLP for operations on that particular day. The STP is also loaded into a computer-based viewing application, the Operations Planning Timeline Integration System (OPTIMIS), to enable easy review by flight controllers in all control centers as well as initial review by the ISS crew. Ultimately, on the day of execution (e.g., Day of Exe in

Figure 5), the entire ISS operations community conducts operations from the OSTP—a single integrated timeline. Figure 7 shows an OSTP as depicted in the OPTIMIS application. During execution day, crew members provide an ongoing status of activity execution using the OSTP. Flight control team members provide the crew with an ongoing status of ground or on-board systems activity execution using the OSTP. For

example, the crew will mark a task “gray,” which indicates it has been completed. These statuses by crew and ground teams are exchanged and synchronized to allow all plan users to follow the execution status on the ground. The Russians additionally communicate a subset of the official OSTP plan to the Russian crew members using a document called Form 24, which is essentially a text summary of the day’s events.



**Figure 7.** OSTP timeline of crew and ground commanding used by all control centers for daily ISS operations. This looks similar to the STP in Figure 6, but here it is viewed in the crew's OPTIMIS. The dashed red line indicates the current time. A pop-up in the center provides additional detail on a specific activity under the cursor.

## Plan Configuration Management

Early discussions with all the international partners during the formative phases of ISS operations development determined that the distributed nature of ISS operations, coupled with the fundamental tenant of a single integrated plan, required a rigorous configuration control process. Without this configuration control, the various control centers and the crew could end up working from old or different schedules. Keeping track of all the changes input through the WLP, STP, and OSTP development cycles is a daunting task. Rigorous control of changes and inputs must be maintained as the planners strive to produce, daily, a single integrated plan from which

all ISS operations teams execute. The on-console flight control teams around the world document any modifications to the timeline from the Final STP in a Planning Product Change Request (PPCR). A web-based tool is used to generate, review, and implement the PPCRs.

Figure 8 shows the PPCR tool summary interface. Each change request is assigned a tracking number based on the increment (i.e., 43-0541 is the 541st change request during Increment 43) and indicates the title of the request, the flight control discipline authoring the request, the status of the request (e.g., Open, Implemented, or Withdrawn) along with an approval status matrix for the ISS control center participants. A PPCR is used to document changes

to existing approved planning products. These changes include modifications or additions to a plan or changes to any details (e.g., start time, duration, procedure reference, execution notes, etc.) for an activity timeline. Specifically, PPCRs are generated to request or document changes from a Final WLP while in STP development, or to request changes to a Final STP. Changes affecting only a single partner require approval by the issuing partner and are provided to the other planning partners as “information only.” This allows each partner flexibility in planning without slowing the process. Other updates affecting crew time or integrated vehicle operations require approval by all international partners. For example, the Russian flight control team might need to adjust the

PPCR #	Title	Discipline	Status	MCH	MCM	POIC	SSI	PC	COL	CC	AT	VCC
43-0541	Final STP for Monday, April 13 (GMT 103)/Окончательный STP (103 CB)	OpsPlan	Open	A	D	IR	IR	IR	IR	IO		
43-0540	US PL Changes for GMT 098 (ground)	POIC-TCO	Open	IR	IR	IR	IR	IR	IR	IO		
43-0539	US PL Changes for GMT 098 (CEO/IMAX)	POIC-TCO	Implemented	A	IO	A	IO	IO	IO	IO		
43-0538	US PL Changes to GMT 99-100 (Ground)	POIC-TCO	Open	IR	IO	A	IO	IO	IO	IO		
43-0537	US PL Changes for GMT 098 (crew)	POIC-TCO Surgeon	Open	IR	IR	IR	IR	IR	IR	IO		
43-0536	US PL Changes to GMT 99-101	POIC-TCO POD	Open	IR	IR	A	IR	IR	IR	IO		
43-0535	GMT 102 PIUV Reconfig post 1B3/4B3 Battery Capacity Tests (Ground Only)	SPARTAN	Open	IR	IO	IO	IO	IO	IO	IO		
43-0534	BME Updates to GMT 98	Surgeon	Open	IR	IR	IR	IR	IR	IR	IO		
43-0533	Delete extra WB placeholders on GMT 102	ETHOS	Open	IR	IR	IR	IR	IR	IR	IO		
43-0532	GMT 099 - Populate WB placeholders with Condensate Pumping	ETHOS	Open	IR	IR	IR	IR	IR	IR	IO		
43-0531	GMT 098 - Delete WSTA Fills (FE-5)//Отменить заполнение WSTA в ГСВ 098 (БИ-5)	ETHOS	Open	A	A	A	IR	A	IO			
43-0530	WPA Replan Part 2 GMT 100	OpsPlan	Open	IR	IR	IR	IR	IR	IR	IO		
43-0529	WPA Part 1 GMT 099 // WPA, ч.1 ГСВ 099	OpsPlan	Open	A	D	A	IR	A	IO			
43-0528	CRONUS Ground Updates GMT 100	CRONUS	Open	A	IO	IR	IO	IO	IO	IO		
43-0527	Delete Water Balance from GMT 102 (SPX Slip Cleanup)	OpsPlan	Withdrawn									
43-0526	Modify ETHOS Ground activities GMT 100	ETHOS	Implemented	A	IO	IO	IO	IO	IO	IO		
43-0525	US PL Changes for GMT 098 (ground and execution notes only)	POIC-TCO	Open	IR	IO	A	IO	IO	IO	IO		
43-0524	COL-CC changes to GMT098\ Изменения COL-CC на ГСВ098	Col-OC/COP	Pending	A	A	A	A	A	A	IO		
43-0523	RS Changes for GMT 098	RS-Planner	Pending	A	A	A	A	A	IR	IO		
43-0522	Crew changes to GMT098 (Crew: JEMAL T/S, BD tasks) / Изменения действий экипажа в ГСВ 098 (экипаж: п	JPlan	Open	A	A	A	A	A	A	IO		
43-0521	Modify OBT-ISS-EMER-SIM to remove outdated Reference document	STL	Implemented	A	IO	IO	IO	IO	IO	IO		
43-0520	Update execute notes for NOD1-STWG-PT2 on GMT 100	ISO	Implemented	A	IO	IO	IO	IO	IO	IO		
43-0519	RS Updates for GMT 102\ Российский запрос на изменение на 102 GMT	RS-Planner	Open	A	A	IR	IR	IR	IR	IO		
43-0518	COL-CC change to GMT100 (HOLD)	Col-OC/COP	Open	IR	IR	IR	IR	IR	A	IO		
43-0517	Add SSC-WIRELESS-SLOW to GMT 100	PLUTO	Implemented	A	IO	IO	IO	IO	IO	IO		
43-0516	BME changes to GMT 098\ Изменения [BME] на ГСВ 098	Surgeon	Implemented	A	A	A	A	A	A	IO		
43-0515	Use XTP for Rec Tk R&R on GMT 100	ETHOS	Implemented	A	IO	IO	IO	IO	IO	IO		
43-0514	Weekly Task List PPCR	OpsPlan	Open	IR	IO	IO	IO	IO	IO	IO		
43-0513	US PL Changes for GMT 098 (add reminder)//\Американские изменения по ПИ в ГСВ 098 (добавить чтение и	POIC-TCO	Implemented	A	A	A	A	A	A	IO		

**Figure 8.** A snapshot of the PPCR tool summary interface. The tool Web page assigns a tracking number in the left column (increment number followed by an incremental number of each PPCR), the title of the request, the discipline that submitted the request, and the current status of the request (Open, Implemented, or Withdrawn). The six columns to the right are labeled for each control center around the world. A PPCR may be indicated as Information Only (IO) in that it doesn't affect another partner's activities but may be something the partner might want to know is occurring. Alternatively, a yellow In Review (IR) means the partners must evaluate and agree or disagree on its implementation. Once the control center agrees, the line item is marked as a green Approved (A).

time during which a cosmonaut is to exercise on one of the pieces of shared exercise equipment. However, before the change can be implemented, the planners will verify that a US crew member is not already scheduled at that time or doing maintenance in that area. Changes are not accepted into planning products without a PPCR. The PPCR form includes specific information regarding the change description, rationale, source (e.g., an

error in the information or a piece of equipment that is broken), resource requirements (e.g., power), scheduling constraints, and initiator. The LRP or OPS PLAN team assesses the feasibility or impact of implementing the change and provides feedback to the initiator as part of the approval process. For example, a flight control team or partner may want to add an activity to a crew member's timeline, but the OPS PLAN team may find it

would exceed the astronauts' allowed workday length. The flight director at each control center grants final approval. Once a PPCR is approved for implementation, the LRP or OPS PLAN team, as applicable, implements the changes in the appropriate plan. The LRP and OPS PLAN teams routinely interface with the various elements of the MCC flight control team to solicit plan inputs, verify procedure references,

and coordinate replanning. This process continues around the clock, 7 days a week; tweaks to the schedule, whether small or large, occur on a daily basis.

The real-time OPS PLAN team is also responsible for reviewing and approving all messages to be uplinked daily for the crew's Daily Execute Package. A significant part of the package is a Daily Summary. As the name implies, this part provides a high-level summary of notable activities and constraints (e.g., "The thruster will be fired at a specific time today, so ensure the window shutters are closed to prevent contamination.") as well as follow-up questions to the crew (e.g., "Last week, a piece of hardware was reported broken. Can you please provide the serial number of the item?") or answers to questions the crew had asked (e.g., "Can I move my exercise on Wednesday to later in the day?"). These messages also include procedure updates, activity overviews (e.g., a big-picture plan for an upcoming spacewalk), or system data. This is the final product generated by the planning team in preparation for plan execution.

Changes to the plan that occur during the day of plan execution, due to anomalies encountered or for a variety of other reasons, are fed back into the planning process by the planners. Constraints for completing activities or urgency to implement new activities in response to system failures (e.g., exercise equipment breakage, toilet troubles, laptop failures, computer network problems, etc.) dictate how quickly plan changes need to be implemented. Again, the PPCR system is used to document these plan changes and work them into future plans.

## Scheduling Challenges

During ISS operations, planners routinely grapple with a number of scheduling problems. For example, scheduling activities that need communications satellite coverage, managing resources and temporal relationships (e.g., Activity B must occur no earlier than 30 minutes after the end of Activity A), scheduling activities for globally distributed users, handling uncertainty in task duration, and wrestling with on-board stowage and worksite issues. Mission planners and crews continue to evolve the understanding of types of information the crews need and how to more effectively tie crews into the planning process during increment execution.

Communication relay satellite scheduling can be especially challenging, given the complex nature of communications requirements, the competition for services with other users (e.g., the Hubble Space Telescope, the Department of Defense), and the uncertainties in coverage quality with variances in vehicle attitude. Science payloads, major events such as visiting vehicles dockings and undockings, spacewalks, and video events intended for the public generally all require using NASA's Tracking and Data Relay Satellite (TDRS) (Ku-band for video and high-rate data transmission; S-band for voice and health and status telemetry. See also Chapter 13). The ISS planners make requests of TDRS services weeks in advance in competition with other TDRS users. Even uncertainties in vehicle attitude, which affects the ability of the radio antennae on the ISS to have the required direct line of sight to the TDRS, and where the

solar arrays might be in their constant motion that sometimes can block the signal, may render a communication pass unusable. These factors make it difficult for planners to commit to specific times more than 1 week in advance for ISS TDRS service needs. Late changes may result in a lack of available TDRS time since service is scheduled on a first come, first served basis. If the ISS Program suddenly needs TDRS coverage—such as for an emergency spacewalk—the NASA flight director can declare the TDRS time as critical, thereby forcing other users off the network. Due to the impacts to other uses, which can include loss of science, this is not done unless absolutely required.

Scheduling use of the exercise equipment is one of the bigger challenges in daily planning. Three main exercise devices are located on the USOS part of the ISS. These devices include Treadmill 2, a Cycle-Ergometer with Vibration Isolation System, and the Advanced Resistive Exercise Device. Crew members are required to exercise a minimum of 2.5 hours per workday and follow strict exercise programs created by the medical team. Additionally, crew members often have preferences as to when they would like to exercise. Some crew members prefer to complete their exercise in the morning, others prefer to spread it throughout the day, and some like to perform their exercises in a particular order (e.g., aerobic followed by resistive). All six crew members must use the Advanced Resistive Exercise Device, thus compounding the planning. When a piece of exercise equipment breaks, a great deal of replanning is usually required until the equipment is repaired.

Planners also contend with sequences of activities where each activity requires the preceding one to be completed, sometimes with additional time between end and start. For example, the repair of a piece of equipment might require the ground control team to power the device off for a few hours before the astronaut performs the repair so that the device will cool down enough to be handled. Even gathering the tools for the repair has to be taken into account since, as with everything in microgravity, activities take longer than they do on Earth. The astronaut also must ensure that another crew member is not using the one item needed for the repair. Also, since every bit of available space is used to stow equipment or supplies, the equipment that needs to be repaired could be situated behind another object, which would need to be temporarily moved to another area. A simple repair can be tough to schedule with the addition of more temporal constraints such as the crew members' desire to eat their meals together, which can be critical for psychological support when away from home and their usual routine for so long.

Crew time is another limited resource that is highly constrained. Ground rules and constraints limit overall scheduled crew time per day to 6.5 hours, with the remaining days' time comprised of exercise (see above), sleep, morning and evening preparation (i.e., time to review the current or next day's plan, review procedures to be used, etc.), and midday meal time. Further, the 6.5-hour scheduled time is bounded by being allowed only after the morning crew/ground planning conference and needing to conclude by the start of the evening crew/ground planning conference. The

goal of managing crew time is to provide as much time as is practical for science scheduling. Science planners also contend with other limited resources such as batteries for small handheld devices, consumable gases (e.g., argon, nitrogen), water, test tubes, sample bags, test strips, etc., thereby further complicating the scheduling problem. Finally, planners must manage constraints imposed or required by the external environment such as day/night cycle requirements, attitude constraints, microgravity requirements, and satellite communications availability. Planners at the various ISS operations control centers manage many of their own resources as well as the use of common resources such as crew time, power, air, other gases (previously mentioned), tools, etc. To accomplish this, the planning teams use complex scheduling software to define and manage all these constraints and resources, and to generate valid effective timelines of crew and ground operations to support each day of ISS operations. Primary to its other tasks, the Houston flight control team, led by the ISS flight director, is responsible for integrating all these plans into a single, integrated plan that is presented in the OPTIMIS.

## Lessons Learned

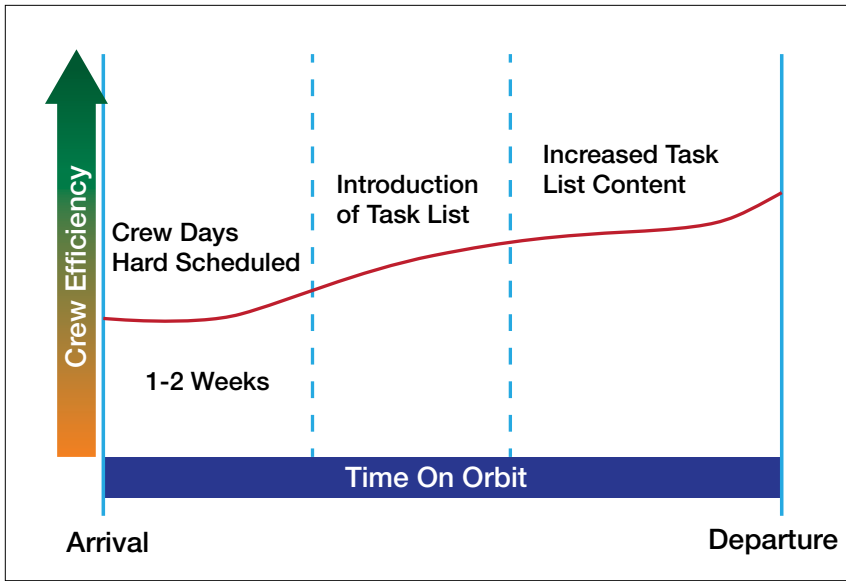
As previously mentioned, on-orbit crew time is at a premium. All efforts are made to minimize unnecessary use of this limited resource. One problem that all planners face is accurate prediction of task durations. Underestimating task duration leads to the replanning of uncompleted activities and, in many cases, requires crews to work longer hours to avoid getting too far behind the general plan. Planners usually arrive at task

duration estimates through ground procedure verification and simulation, as well as through previous related experience, as described above.

The time is usually increased to the predicted duration for new tasks or for astronauts executing a task for the first time on-orbit. In many cases, additional time is scheduled for crews to review procedures. A good example of this occurred during Expedition 1. The crew was asked to connect a newly flown control box to an on-board laptop to allow manual control of the Control Moment Gyros heaters (see Chapter 7) that had been experiencing extreme thermal fluctuations. Ground controllers, at the time, had no means to control the heaters. Upon reviewing the procedures on the ground, planners initially determined that 2.5 hours would be required for the astronauts to review the procedure and execute the task. The initial performance by the crew took 2.5 hours. However, subsequent performance only required 1.5 hours because of the familiarity gained with the apparatus and procedures.

Early planners quickly learned the importance of accounting for the overhead involved in worksite preparation, equipment gathering, worksite cleanup, and equipment stow. A good example of this occurred during Expedition 4. The crew was asked to take samples of the US Laboratory Low and Moderate Temperature Loops (see Chapter 11) to check for microbial growth or particulate contamination. Ground task duration estimates predicted about 1 hour of crew time for the activity, including gathering the equipment. However, upon review of the procedure, the crew members pointed out that to access the loops, they would need to remove two





**Figure 9.** Crew efficiency with time on orbit. Shortly after arrival, new increment astronauts need time to familiarize themselves with the location of items and how to live and work in microgravity. As the crew member gains more experience and acclimates, task efficiency increases.

panels on which they had deployed and affixed several laptop computers and other general support equipment. Preparation of the worksite was then estimated to add at least 1 to 2 hours to the initial task prediction. This illustrated, to ground controllers and planners, the need to keep crews directly involved in the planning and replanning process as well as keep track of where everything on the ISS is located. Accounting for this additional overhead is especially important when scheduling the first couple of weeks of a newly arrived crew that is still in the adjustment phase. Maintaining a thorough inventory database and routinely providing time for crews to organize the habitat go a long way in minimizing the time needed to find equipment and organize worksites. The increased efficiency gained by the crew with time on orbit also helps the situation (Figure 9). Repetition of task execution, the experience of living in space, and the increased

situation awareness gained by crews living and working in the same workspace for many months lead to efficiency in performing routine tasks as well as executing new tasks. By the end of an expedition, crew members are efficient in knowing the time required for task execution. Returning crew members (e.g., those who flew on the ISS during a previous expedition) have a much shorter learning or relearning curve to achieving peak efficiency.

Not only is proper duration estimation and worksite preparation important to the success of the plan, it is very important for crew psychology. Early in the ISS Program, astronauts often exceeded the ground rule for the day length. A common complaint was poor estimation of task length (some of which was understandable since almost everything was “new”) and not enough time allocated for worksite preparation. During this early phase, astronauts often felt as if they were running a relay race. They

didn’t want the team to fall behind, so they often worked extra hours to make up for problems or to perform extra science, as discussed above. That pace might have been acceptable for short-duration shuttle missions, which were about 2 weeks long; however, in addition to affecting sleep and performance, that pace can lead to burnout over a 6-month increment. The flight directors now manage the crew day much more carefully. This proved to be critical for the success of the yearlong increment of Scott Kelly and Mikhail Kornienko in 2015–2016. Pacing is necessary to maintain focus on the critical task of operating the ISS.

Early on, it became evident to both the crew members and the planners that ISS crews need a bigger-picture view of the plan, along with a detailed daily timeline, to provide a sense of what is coming up and where the crew is headed. This helps improve success in two ways. First, from a psychology point of view, the detailed timeline helps crew members know how their daily tasks fit into the bigger picture and ensures that they feel part of the team. Second, it helps with efficiency. For example, if the crew members put tools away for a task but know a similar task will be performed the next day, they might temporarily stow the tools at the future worksite, thus saving time down the road. To this end, the OPS PLAN team developed a monthly calendar plan. This plan view is regularly updated, and is used as a basis for the Weekly Planning Conferences—i.e., a dedicated time each week where the OPS PLAN team for the increment discusses the upcoming week’s plan with the crew over the space-to-ground voice loops. Now, crew members are more frequently

tied into replanning discussions to obtain the benefit of their situational awareness and experience. They are involved in the planning, even at the OOS stage. During increment execution, crew and ground operators conduct daily planning conferences. The morning conference focuses on describing unique supplementary information for that day's schedule, whereas the evening conference concentrates on reviewing that day's accomplishments and reviewing the next day's detailed plan.

An additional lesson learned from the Mir, Skylab, and early ISS flight planning experiences was that crew flexibility can lead to increased crew productivity. Crew timelines today include many activities marked as "flexible," allowing crew members to perform them whenever they want during the day. These activities have no constraints (e.g., a strict deadline, or when resources such as power are needed). Allowing crew members to perform many of their routine activities such as exercise, the midday meal, and on-board training modules when it makes the most sense for them enhances productivity (e.g., multitasking). In addition, some astronauts—especially those who have flown to the ISS previously—may be more efficient in completing tasks than have been estimated by the ground for a "typical" crew member. Original ISS planning, which was based on Space Shuttle planning heritage, consisted of hard scheduled plans for the crew each day. These activities were to be performed in a linear fashion at prescribed times, thus leaving no option for flexibility based on crew situational awareness or multitasking. Derived from both Skylab and Mir, the notion of a "job jar" or "task list" of additional

unconstrained activities folded into ISS operations planning. A task list activity is something that needs to be done at some point, but which doesn't make it into the estimated time on a given day or week. If the astronauts get ahead on the timeline, which happens if the planning is done well and/or crew members are highly experienced, they may have a few minutes to complete one of these activities. Today, daily crew plans are highly populated with flexible activities and contain a robust task list. This shift in planning philosophy from more-optimized plans to more-flexible plans leads to more crew autonomy. Crew autonomy is seen as necessary for further crew exploration beyond low-Earth orbit or to Mars, where astronauts will be exposed to significant time delays and will thus be required to manage their plans and vehicle more autonomously from ground teams. The ISS has also seen an increase in crew productivity and efficiency with the expanded use of flexibility and task lists.

The arrival of new crews to the ISS creates an opportunity for an operational dichotomy where new crew members, who are adjusting to life in space in an unfamiliar environment, are matched with a veteran ground team that operates at a high level of efficiency. To prevent this dichotomy, a throttling-back effect is imposed on the ground team while, at the same time, providing time for the on-board crew to acclimate. Through Gr&Cs, schedulable crew time during the first 2 weeks on orbit is reduced to permit time for adjustment and settling in. This allows the crew and ground to jointly arrive at an operations pace for the increment. This process is repeated with the

start of each increment. However, considerations for particular crew complements to account for crew experience are made to increase ISS science returns. For example, the day after Peggy Whitson arrived for her second stay on the ISS, she called the ground team to report completion of all activities on her timeline as well as everything on the task list, and that she would appreciate additional tasks. Another complication is that the ground controllers, who work on weekly shifts, are not tied to specific crew arrivals and departures. As such, those ground controllers will achieve a level of efficiency independent from ISS crews. Lead flight controllers from every system are assigned to each increment to help mitigate this problem. Their task is to ensure uniformity from week to week for a given crew.

Over time, the flight controllers and crew members have learned that staying synchronized is crucial, yet doing so non-intrusively is key. Asking a crew member repeatedly whether a task is done can get annoying. The OPTIMIS tool was modified to allow the crew to add crew notes (i.e., brief messages to the ground) in each activity, which will provide additional information about the execution of a particular activity (e.g., stowage information after completing a task, equipment-identifying information such as serial numbers or barcode numbers, or comments about the execution of an activity—how long it really took, procedure issues encountered, etc.). The flight controllers and crew found that this nonverbal means of communicating certain information, as mentioned above, is highly effective and frees up the

space-to-ground channels for more important conversations.

Following the conclusion of an increment/expedition, mission planners, through the Lead Ops Planner, work with the ISS Program operations team to reflect overall increment metrics of accomplishments in the Post Increment Evaluation Report. Additionally, the lead increment flight director conducts a lessons-learned meeting to roll up significant topics that need to be either generically addressed for all future increments or unique items that need to be fed into the next increment's execution team. In many cases, planners provide lessons learned on activity duration estimations (based on crew feedback) as well as lessons learned on activity planning conflict resolution. The aim is to keep the ISS safe for crew operations while continuing to make operations more efficient to support the goal of greater scientific gains.

minimal wasted time. Planning was difficult during assembly of the ISS due to constant changes. Some of these changes were necessary to the evolving vehicle, whereas some were induced by the Space Shuttle Columbia accident and concentrated on the vehicle build-up. In 2009, the ISS increased from three permanent crew members to six, and began the shift in focus from assembly to science. Starting in 2018, commercial crew vehicles will add further complexity as the rate of scientific operations increases with a permanent crew of seven.

## Conclusion

Flight planning has been a necessary yet ultimately challenging task since the beginning of the space program. Each mission that NASA performed brought its own unique planning and scheduling challenges, which were met by planners using the latest technology of the day. Planners continue to meet these with a credo of flexibility and a constant eye toward improvement. Unlike other NASA projects, the ISS Program involves a worldwide team working 24/7/365. Plans for every activity that takes place on the ISS start years out and are continuously refined in detail as the actual time approaches. This ensures maximum success and



# Chapter 2 Day in the Life:

Living and Working  
in Space and  
on the Ground



*The first six-person crew—Increment 20 in 2009—included astronauts and cosmonauts from all international partner agencies for the first (and, so far, the only) time. From left: Canadian Bob Thirsk, European Frank De Winne, Russian Gennady Padalka, Russian Roman Romanenko, Japanese Koichi Wakata, and American Michael Barratt.*

***The International Space Station (ISS) is a hub of never-ending activity, around the clock, around the world, every day.*** On board the orbiting laboratory, the crew members are not only the laboratory technicians, they also keep the facility up and running by working as janitors, plumbers, electricians, information technology support, medics, kitchen crew, and housekeeping. They manage the arrival of vehicles delivering new crew, new equipment, and additional supplies, as well as the departure of vehicles returning crew and equipment to Earth or disposing of trash. They are responsible for completing any necessary repairs or reconfiguration that cannot be done

by simply changing parameters in software. On the ground, the flight control teams—both on console and off—support the increment as a whole by working between control centers and management teams around the globe to keep the crew safe, keep the ISS running smoothly, and meet all mission objectives. Together, the on-board crew and the ground teams respond to problems, incorporate new priorities, and adapt the mission plan as conditions change—sometimes on a daily basis.

Crew rotation flights are currently done using Soyuz vehicles, launched by the Russian Space Agency Roscosmos from Baikonur, Kazakhstan. A Soyuz can fly up to

three crew members, and can stay on orbit and docked to the ISS for about 6 months, where it is available as a “lifeboat” to return the crew to Earth in the event of an emergency. Four Soyuz crews have been flown each year since 2009, maintaining a total crew of six people on board the ISS most of the time. Prior to 2009, the ISS had a permanent crew of three people, with two Soyuz launches per year. The launches take place approximately every 2-4 months. Usually, flights are arranged in a pattern of “indirect handovers”: one Soyuz will undock just before launch of the next, so the crew goes from six people on board down to three, and back up to six when the next Soyuz

arrives. The pattern of launches and the number of crew members on board at any time will change when the new commercial crew vehicles being built by the United States are ready to rotate crews around 2019 (see Chapter 14).

ISS operations are managed in periods called increments, which are defined by the on-board crew complement: an increment is the period of time in which a dedicated crew of astronauts and cosmonauts are on board the ISS under a specific commander. Each new increment begins when one commander hands over to another before departing the ISS. Before 2009, each increment lasted approximately 6 months – the full duration of each Soyuz crew’s stay on orbit. Today, each increment corresponds to the period of overlap between two Soyuz crews, so each increment lasts about 2-4 months, and each ISS crew member serves on two increments.

As discussed in Chapter 1, preparation for flight begins years in advance. A team of flight controllers is assigned to manage the increment. Depending on each discipline’s involvement in crew training and mission planning, flight controller assignment may happen a year or two before the increment begins. A lead flight director is assigned to manage this team and lead the overall operational mission integration and preparation. The flight control team follows the six crew members through their final training as they transition from generic skills to lessons more closely tailored to the specific tasks and research that will be performed during their time on orbit. The two different Soyuz crews will launch 2 to 4 months apart, and each will be part of two increments. Therefore, each crew may work with two different lead

flight directors and teams during its time on board the ISS.

This chapter describes how the team of flight controllers in Houston, Texas, their international partner counterparts around the world, and the ISS Program, engineering, safety, and medical support teams work together to manage day-to-day operations of the most complicated international laboratory ever built.

## Before the Crew Reaches Space

Mission integration and preparation is organized through a Joint Operations Panel (JOP), chaired by the increment lead flight director. All of the assigned flight controllers, instructors, ISS Program representatives, engineering and safety team members, along with partner teams supporting payload operations and international partner teams are members of the JOP. This

team will review new operations, priority adjustments or requests from ISS Program management, new candidates for complex tasks such as extravehicular activities (EVAs) or vehicle relocations from one docking port to another, and new data on ISS systems performance.

The team also reviews any significant changes being made to crew training and, in some cases, participates in the actual training events. For example, each crew of six holds one emergency scenarios training event during a time when both sets of three crew members are in Houston. The lead flight director, along with his or her lead training team, will observe the event (Figure 1).

The flight director and flight controllers assigned to lead that activity might also observe other significant training events, such as EVA training in the Neutral Buoyancy Laboratory or rendezvous training on the simulator for visiting vehicles. Flight control team members take



**Figure 1.** Expedition 49 astronauts and cosmonauts discuss an emergency scenario exercise with the training team and the lead flight director. From left to right: Andrei Borisenko, Interpreter Ksenia Shelkova, Sergey Ryzhikov, Shane Kimbrough, instructors Amy Holloway-Margiolos (standing), Bobby Fard, and Elisca Hicks, and Flight Director Amit Kshatriya (standing).

every opportunity to make sure they understand the crew members' perspective and how they work together in complex operations and critical scenarios.

In the month leading up to the beginning of the increment, the various teams within NASA and at the international partner agencies conduct a series of Flight Readiness Reviews, culminating with a final review led by NASA Associate Administrator for Human Exploration and Operations William Gerstenmaier. At this review, the ISS Program and all supporting teams confirm readiness for the beginning of the new increment, the landing of the Soyuz with the current ISS commander and crew, and the launch of the next Soyuz.

Three weeks before the increment begins, the real-time process “kicks in” for mission planning. At this point, the increment team starts to participate in day-to-day planning and integration in Mission Control. About 1 week before launch, most of the planning process is being done for the new increment. By the time the new ISS commander has taken charge on board, the increment lead flight director and his or her team is well and truly installed in Mission Control.

## A Day in Space—and on the Ground

At about 7:30 a.m. (0730 Greenwich Mean Time [GMT]), flight control teams in Houston, Huntsville, Munich, Tsukuba, and Moscow wait for the ISS commander to make the call that marks the official start of the workday for the crew on board the ISS:

“Houston, Station—good morning! We are ready for the morning DPC.”

Each morning's Daily Planning Conference (DPC) gives the flight control teams a chance to ask questions and provide any late-breaking news or updates to the plan for the day. Houston starts things off with general items and anything related to core US Segment systems. If needed, the other four United States On-orbit Segment (USOS) centers take their turns: Huntsville for the NASA experiments and related systems; Munich for the Columbus module and European Space Agency experiments; and Tsukuba for the Kibo module and Japan Aerospace Exploration Agency experiments. All of these conversations are in English. Once the USOS operations have been covered, it is Moscow's turn to address anything related to Russian

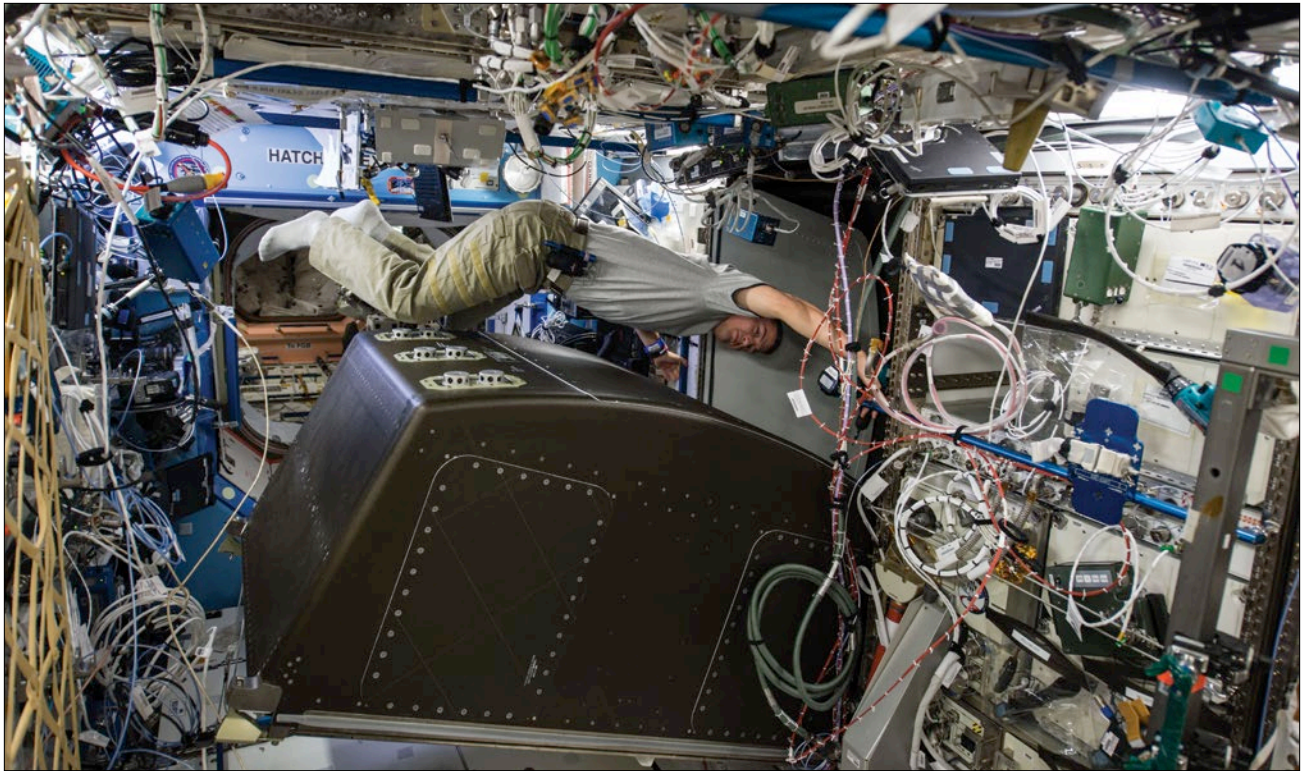
Segment systems and experiment operations. This part of the conference is in Russian. The whole morning DPC may take anywhere from 2 to 15 minutes, depending on the complexity of that day's plan.

By the time this conference takes place, the crew members have been awake for about 1.5 hours. That early morning time is set aside for their normal waking-up routines, creatively labeled “post sleep” on the crew's timeline. They also look at the ISS version of the morning news: a message sent up every workday and once per weekend called the Daily Summary, which is used to ask/answer questions and provide key pieces of data that might be too detailed or too repetitive to

## Synchronizing All Watches

“Morning,” to the crew, has nothing to do with sunrise. The ISS orbits the Earth once every 90 minutes, thus the crew sees the sun rise and set every hour and a half—that's 15 or 16 times each day. Instead, a common time zone needed to be selected so that the crew—and all of the teams on Earth—are on the same clock. The ISS Program picked Greenwich Mean Time (GMT), also known as Coordinated Universal Time (UTC) or “Zulu” time. The crew gets up at about 0600 GMT, starts work around 0800, ends the workday at about 1700 GMT, and goes to bed at 2130 GMT. This means the crew's workday most closely lines up with the Columbus Control Center workday in Munich, with Moscow just a couple hours ahead. For the Kibo team in Tsukuba, the crew's workday begins in late afternoon, while for Houston and Huntsville, crew members wake up in the middle of the ground controller's night. Although flight control teams are on console in all those locations, 24 hours every day, the teams tend to plan complex or intensive activities to line up, as much as possible, with local working hours. This applies especially when it comes to major systems maintenance or assembly of new equipment—i.e., activities that might need extra support from specialist engineering or support teams. Thus, major Kibo, Columbus, and Russian Segment systems work tends to be scheduled in the crew morning, while NASA tends to schedule major work on its systems, or in its modules, later in the crew day. Science activities and related support work are scheduled throughout the day for investigative teams around the world.





**Figure 2.** Flight Engineer Kjell Lindgren is photographed in the US Laboratory as he prepares one of the lockers for installation of the Common Communications for Visiting Vehicle hardware that will be used by the new commercial crew vehicles (Chapter 14).

talk through in the morning DPC. On some mornings, crew members are also busy with life sciences and medical data collection—e.g., drawing blood samples, etc.—in which case some post-sleep time is blocked for them after DPC to make up for their early activities.

Once the DPC is complete, the crew day begins. A video camera is turned on, and is usually in the US Laboratory module, Destiny, which is generally a thoroughfare for most of the crew. If science or other work is planned in other modules, cameras will be used in those places, as well. The ability to see the crew members, sometimes looking “over their shoulder” to follow their activities, helps the team on the ground understand the situation on board, anticipate questions, and turn around answers more effectively (Figure 2).

But the video is treated with special care. After all, the ISS is not just a laboratory: it is where the crew members live. Cameras are not used outside their scheduled working week, or in areas where a private activity such as a family conference, medical checkup, or exercise is taking place.

Morning DPC occurs around 1:30 a.m. in Houston—basically in the middle of the night for the flight controllers. Mission Control is quiet at this hour. Usually, only the flight director, core systems team, and any specialists needed to support the crew’s morning activities are on console. On a good day, the increment team is at home and asleep. As the increment team starts to wake up in Houston—around the crew’s lunchtime—they start checking in with the real-time team to see how things are going. Unless

they got called in overnight for a problem, or came in early to watch a particular activity, the increment lead flight controllers will start by reading their discipline’s console logs from the past few shifts. This tells them what has happened in their system, maybe what agreements have been reached with their international partner counterparts, or what questions have come up from the crew or other team members. Some mornings, everything checks out as expected. However, most of the time, something unexpected is documented in the logs or on the crew’s timeline, which means the flight controller’s first order of business will be to figure out what went wrong, or what needs to be replanned.

The increment lead flight director also hits the ground running by reading the console logs. He or she checks



Photo courtesy of Robert C. Dempsey

**Figure 3.** Lead Increment 44 Flight Director Michael Lammers works in the Flight Director's Suite, a small office that overlooks the ISS Mission Control room in Houston.

in with other team members and ISS organizations as appropriate, given that day's activities (Figure 3). Then the meetings begin, sometimes as early as 6:00 a.m., Houston time. The ISS Mission Management Team (IMMT) meets twice a week. The IMMT is chaired by the ISS Operations Integration Manager Kenneth Todd and includes representatives from each of the international partner agencies, and from all offices within NASA's ISS Program as well as flight operations, safety, engineering, and health and medical. The IMMT approves mission priorities and real-time Flight Rule changes and waivers, and conducts final readiness reviews for major activities including launches, dockings, landings, and EVAs, and dispositions major anomaly investigations. The chairperson usually conducts a series of one-on-one tag ups with various partner agencies and commercial vehicle teams before each IMMT. The increment lead flight director supports

the process, as well. Twice a week, the NASA team meets internally with the ISS Operations integration manager at an operations tag up for more focused review of NASA internal topics, sometimes in preparation for an upcoming IMMT presentation to the rest of the partnership. Owing to the continuous operation of the ISS and the complexity of the systems, daily meetings between the operations team, the engineering support team, and the integration manager normally occur in between these more formal reviews.

In parallel, the crew continues to follow the timeline. Each crew member is scheduled for two daily exercise sessions (Figure 4). The ISS has two treadmills and two stationary bikes— one of each in the Russian Segment and US Segment. The equipment also includes one resistive exercise system for strength training. Managing to get all six crew members scheduled for the exercise they need without double-booking the associated equipment can be a tricky planning problem, particularly

on days when maintenance is needed on any of the exercise equipment, or even on other systems nearby.

One hour of each crew member's day is set aside for the "midday meal." Attempts are made to line these up for all, or most, of the crew. The crew members can use this time as they see fit. This is a chance for them to take a break during a busy day, grab a bite to eat, and maybe hang out with their crewmates for a bit before getting into the afternoon schedule. Aligning the times for the entire crew also provides psychological support for long missions away from friends and family.

As the afternoon progresses, the ground teams—in addition to following along with the crew members as they work through the timeline—are reviewing and updating the next day's plan. The goal is to get an updated version on board before about 1730 GMT so that it is on board when the evening DPC takes place about an hour later. The evening DPC starts with a crew call to Houston, as with the morning DPC. The calls then go around the world to control teams again for any comments, questions, answers, and last-minute bits of news from the day, ending with Moscow. As soon as the DPC concludes, the crew's workday is officially over. All interior camera views are turned off to provide the astronauts privacy during their "evening" time. Except for occasional conferences or short research activities, the crew's evening is marked "presleep" on the timeline, followed by a 9.5-hour stretch marked "sleep." NASA does not track how they use that time, and no one calls the crew members or otherwise disturbs them unless their help is needed right away to deal with a major problem on board.



**Figure 4.** Expedition 7 (July 8, 2003) Science Officer Ed Lu exercises on a Cycle Ergometer Vibration Isolation System in the US Laboratory. Each crew member is scheduled for two exercise sessions per day.

The workday never really ends for the flight control teams. Most of the teams—Houston, Huntsville, Munich, Tsukuba—split the day into three shifts of 9 hours, with an hour

of overlap for the teams to hand over. In Moscow, the flight control team works a full 24-hour shift, handing over just before morning DPC, at the start of the workday in Moscow.

The flight control teams on console are responsible for putting together the detailed timelines for the upcoming 7 days based on ISS Program requirements and direction from the increment flight control team. As discussed above, before the end of each crew workday, the ground teams will review and discuss any major changes for the next day's timeline so that the crew can be informed as to what will be discussed during the evening DPC. The team may make additional changes while the crew sleeps, or may simply “fill in the blanks” by attaching procedures and messages to provide all the detail the crew and flight control teams will need to execute the timeline. The console team also typically reviews and updates the “3-day-out” and “7-day-out” timelines each day, so that they are continually looking ahead a few days to make sure all the details needed to complete each day's objectives are captured in the plan. A standard process described in Chapter 1, with milestones throughout each 24-hour day and 7-day week, allows all of the control teams a chance to make inputs to each plan review before the final timeline approved and put on board for execution. The detailed plan for the day might not be finalized until a few hours before the crew awakens, even if the major objectives for that day were selected weeks, or even months, ahead of time.

The increment lead flight controllers continue to hold JOPs as well, now focusing on assuring all details needed to support planned operations are ready to go, including the procedures, flight rules, analysis, and any associated agreements with international partners or



**Figure 5.** The Increment 40 JOP, working in Mission Control Center Houston, reviews current and future activities, and coordinates all the key elements between the engineering and science teams as well as the international partners.

commercial providers (Figure 5). It may take quite a bit of coordination and detailed development work to put the procedures and supporting material together as well as testing or simulating the process before a specific operation. The JOP coordinates that work, and the individual lead flight controllers spend most of their days building those detailed products for final review and approval before they get attached to the appropriate plan. Although many activities have become routine, the dynamic and evolving nature of the ISS necessitates the continuous development or modification of many procedures.

The increment team, meanwhile, is looking out at the weeks ahead, and working to find homes for all the activities that the ISS partnership has agreed are priorities for this mission. This is an ongoing process. The increment manager, representatives of the ISS Program office that ensure the right activities are being

performed, and their team in the Increment Management Center regularly review the Increment Requirements Definition Document (see Chapter 1). Those priorities are allocated to different stages in

the increment via the Current Stage Requirements Document, which breaks down the 6-month Increment Requirements Definition Document period into the stages defined between major mission events—



**Figure 6.** Increment 44 Lead Flight Director Mike Lammers (sitting) discusses crew activities with fellow Russian Flight Director Alexei Buchilin (far right) and his interpreter Paul Kharmats. The Russian Space Agency houses several of its team members as part of the Moscow Support Group in Houston, while a number of NASA flight controllers work in Moscow as part of the Houston Support Group. See also the Introduction.

Photo courtesy of Robert C. Dempsey

usually vehicle launches or landings. The increment lead planning team then works the stage priorities into upcoming weekly plans. Once a week, the increment lead flight director and the whole team review the next 3 weeks in the Weekly Plan Review. Crew activities are assigned, crew workday durations are tallied up, task list items (“job jar” activities that can be completed any time the crew is free), and off-duty days or holidays are planned at this meeting. In addition, recent trends on system performance, consumables usage, and upcoming vehicle traffic are accounted for, and associated on-board activities may be adjusted.

In between meetings, the lead flight director, who is set up in an office in Mission Control (Figure 6), works with all their counterparts, flight control team members, and ISS Program cohorts to address issues and develop future priorities and plans. On any given day, the flight director may be working with people who are down the hall, in the next building, halfway around the world, or just one time-zone away.

## Time Off, Conferences, and Celebrations

Unlike a Space Shuttle mission that would last about 2 weeks at most, an increment mission lasting 6 months is a long time and therefore the crew members need time off to prevent them from burning out. Each expedition crew agrees upon its holiday schedule prior to flight. The crews need to decide this together, since different countries celebrate different holidays. Each Soyuz crew gets about four holidays during their 6-month stay. Some crews end up celebrating both the Eastern and Western Christmas



**Figure 7.** The crew shares a meal in the Node 1 during Christmas 2009. From left to right: Japanese astronaut Soichi Noguchi, cosmonauts Maxim Suraev and Oleg Kotov, and American astronauts T. J. Creamer and Jeffrey Williams (commander).

holidays (Figure 7). When those holidays are also celebrated in one or more of the partner Mission Control Centers (MCCs), those teams get to help the crew celebrate, and vice versa. Sometimes, crew members send food to Mission Control via Earth-based friends and family. The flight controllers will sometimes put together a special message for the crew, or uplink video views from inside MCC to say “hello.” These activities help keep morale high both for the crew members, who are totally isolated on the ISS, and the flight controllers, who have to spend long hours away from families during the holidays to support operations.

In addition to holidays, crew members receive regular time off. They generally work Monday through Friday, and have Saturday and Sunday mostly to themselves. Some time may be scheduled for short stretches of work—e.g., routine systems maintenance, housekeeping

and cleaning, science or medical sample collection—but on a normal weekend, this time is limited to an hour or so each day.

What do ISS crew members do with time off? Yes, they have television – when the ISS has a communication link with the ground, MCC can route video to an on-board computer. Limited bandwidth means only a couple of feeds can be sent at a time, though, and MCC is in charge of changing the channel. They have internet access—not fast, and not all the time, but they can tweet or surf a bit. They can choose from an impressive stash of digital videos (mostly movies) on board. The stash gets refreshed periodically—sometimes with releases that have yet to reach theaters. Many crew members bring up supplies for their own hobbies. For example, the ISS has established quite a collection of musical instruments over the years. Models have been assembled, quilts

have been pieced, and art has been made on board the ISS. See Figure 8.

The crew schedules conferences every week with various folks on the ground, for work and for personal contact. Private video conferences for each crew member with their family are scheduled every weekend. Each week, every crew member has a one-on-one video conference with his or her flight surgeon who monitors that crew member's health. Periodically, the ISS Program manager and chief of NASA's Astronaut Office schedule conferences with each crew member to check in with them directly. Each crew member can also organize a few special conferences with whomever he or she chooses while on board the ISS.

Crew members can make phone calls via laptop—i.e., “voice-over internet protocol” (see Chapter 13)—and through that means can contact family, friends, and colleagues any time the ISS has the right kind of communications link to the ground. There is nothing quite like the surprise of that first phone call from space, and it provides a huge morale boost to both the crew and the flight control team to be able to have such a direct line of communication.

At the end of each working week, NASA's lead flight director and the lead Russian shift flight director hold their own conferences with the crew. These are often “working discussions” where the ground teams fill the crew in on any developments regarding upcoming launches, program decisions, or new activities, and can answer questions about any issues being tracked or worked for the increment. It also is a time for the crew and ground to relax and unwind with some good-natured kibitzing. In addition, since the flight directors often act as advocates for



**Figure 8.** Examples of free time for the space station crews. Top: Dan Burbank, Expedition 30 commander, plays a guitar in the US Laboratory on December 16, 2011. Bottom: Expedition 45 crew members watch an advance screening of the movie *The Martian* in the Unity Node 1. Clockwise from left: Flight Engineer Oleg Kononenko, Flight Engineer Sergei Volkov, Commander Scott Kelly, and Flight Engineer Mikhail Kornienko.

the crew with the rest of the ground teams, these conferences are one way for them to stay in sync with each other on issues or concerns. It can also be a good chance for team building. When a complicated maintenance activity is coming up, for example, the flight director might invite the Operations Support Officer or the hardware owner (or both) to come talk to the crew members in

case they have questions about the procedures. When crew members from other international partner agencies are on board, those teams will hold a weekly conference with their crew members, as well. Finally, special working conferences will be scheduled to help the crew prepare for some complex operations, such as complicated maintenance procedures, EVAs, or visiting vehicle operations.

## Chasing the Red Line

*Sunita Williams, Expeditions 14/15 and 32/33*

Every day is different, but they all have one thing in common: the Red Line, which is either chasing you or you are chasing it (see Chapter 1, Figure 7). All activities are planned out—even exercising (mainly to accommodate all the crew members on the limited equipment). But that's okay, because there is no way one individual could think of all the things that need to be done, or prioritize them.

The main categories of activities are science, maintenance, public relations and outreach events, and robotics and spacewalks; however, the categories also include installation of new or upgraded modules and systems, since the things need to be fixed or added on the inside and outside as the ISS continues to evolve. The activity subject matter can range from the mundane to the incredibly complicated. In any given week, you could be updating the on-board computers, setting up tools for a spacewalk, practicing grappling a free-flyer spacecraft, fixing the toilet, fixing the water system, inventorying food and supplies, sequencing DNA, setting up for fire experiments, taking your own blood samples, making contacts through Ham radio, and talking to the NASA administrator, a Queen, or even the President of the United States! The science never stops up here—we are in microgravity and we can't escape. Even cool science experiments have mundane aspects, such as when we had to clean the aquarium and remove air bubbles—which, ironically, could kill the fish in weightlessness—for some Medaka fish we were studying. Of course, we need to plan time for exercise, eating, and hygiene as well.

Whether I had two other crewmates, such as on my first expedition, or five as I did on my second visit, one key element was that everyone has a great sense of humor, even with all the different personalities. Humor is essential to living in an environment like this.

We are always interacting with the people in Mission Control. They are our team, our family. Our mood on the ISS can dictate their mood in Mission Control. Likewise, their mood in Mission Control can dictate our mood on the ISS. We are symbiotic by the nature of our work together

on this complex and extraordinary station in space. Mission Control watches our backs every night as they monitor the station system. This allows us all to sleep on the same schedule, thereby making us a stronger team.

On the ISS, we have to monitor ourselves and our psychological health, as well as our physical health. You can work all the time, but everyone needs a break. Everyone needs a reserve in case of an emergency in the middle of the night. To function normally, the space station runs on a regular Earth workweek and workday. We emphasize taking a break for lunch, but each person needs to think ahead and plan his or her next meal. Some of it needs to be hydrated or heated up, which takes time for the water absorption. Best not to rush these things. So, in the process of grabbing a bag of coffee and heating up veggie quiche, we usually put some food in the heater to be ready for lunchtime. The Russian food is generally some type of meat with rice, noodles, and kasha, which is best heated up. It's hearty food! Part of the fun is seeing what is available to eat. We eat out of a box for 10 days or so. We don't open another box until that box is done. So, the philosophy was not to save something, because someone else will eat it. Eat what you think is best that day. There will be a new best thing the next day.

Often on the weekend, we try to have a family dinner where everyone pitches in. We would all get our special food and spread it out on our table. One time, we had Azman's sausages—something I was able to import from Cleveland—cooked and sliced. Yum! Everyone loved them. I was only able to save a couple for later. We had corn tortilla chips with bean dip and jalapenos. One of the very special packages we received from a recent Progress flight included fresh garlic, lemons, apples, and grapefruits fresh from Kazakhstan! Food and friendship are all part of the maintaining our health—both physical and psychological.

Luckily, exercise is part of our daily routine, and it is a great stress reliever. Most folks also have space hobbies that help them deal with stress—hobbies such as being in contact with friends and family at home through the IP phone or net meetings, doing self-designed science experiments, taking videos and pictures, writing in a journal, doing social media, etc.

## Complex Operations

Many days are anything but normal. A vehicle launch and rendezvous, a spacewalk, a failure on board—all these events can rearrange the crew's working schedule, and require the attention of a lot more specialists on the ground. Most of the time, a separate lead flight director and a team of lead flight controllers and other specialists are assigned to that specific activity. This lead team coordinates with the increment team to make sure it is clear who will do which tasks to prepare for and execute the operation, and how the right team members will coordinate with the on-board ISS crew.

Planning an EVA is a complex task for the ISS team and crew. When everyone involved knows far in advance that an increment will include a spacewalk, and the

tasks for that spacewalk are well-defined, the crew members can train on those tasks before they launch, and the flight controllers building the EVA plan can account for their specific experiences in training, preferences, etc., as they put together the final plan and procedures for the EVA. Many times, however, one or more spacewalks were added to an increment to deal with failure of critical hardware. Although all EVA-certified astronauts get preflight training on the significant tasks involved in critical hardware replacement or repair, in such cases the flight control team does not have a specific EVA timeline to walk the crew through preflight. Once the failure occurs, the flight control team starts planning the recovery spacewalk(s), and builds the associated procedures and timelines for the crew. This is typically done

via Team 4, which is described in more detail in Chapter 20. A flight director is assigned to manage that effort and lead the team that will support the EVA. This team will coordinate with the increment lead flight director to make sure all the preparation and recovery tasks can be integrated into the increment plan, which is then brought to the IMMT for final approval (Figure 9).

On the day of the spacewalk, the designated crew members spend several hours getting suited up and ready to go outside. Once in their suits, they execute a sequence of steps to safely depressurize the airlock so they can open the hatch and go outside. An EVA timeline is carefully choreographed ahead of time, and the team on the ground is supporting the crew literally every step of the way up to and during the spacewalk to respond to issues or



**Figure 9.** The Expedition 46 Team 4 flight controllers discuss how to repair the stranded Mobile Transporter in a meeting of the IMMT on December 18, 2015.





**Figure 10.** NASA Flight Director Dina Contella monitors the launch and docking of the Expedition 46/47 crew (Yuri Malenchenko, Tim Kopra, Tim Peake) on Soyuz from the Baikonur Cosmodrome in Kazakhstan on December 15, 2015.

develop work-arounds in real time, as needed. A spacewalk may take 6 or more hours outside. Once the crew is back inside, a couple hours of work is required to get the airlock repressurized, get the crew members out of their suits, and (essentially) close up shop for the day.

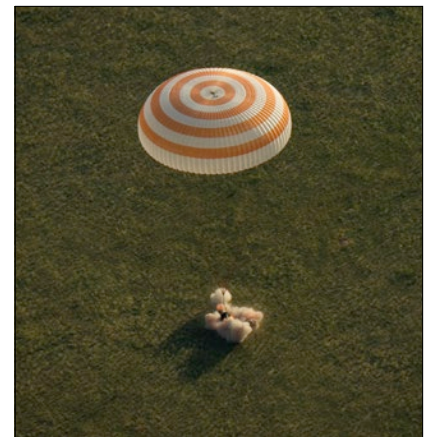
Vehicle dockings can be just as complex, especially for the ground team, although in most cases the ISS crew does not have as much of the workload as on an EVA day. In the weeks prior to the arrival of a visiting vehicle, the lead team assesses the ISS power requirements, reviews any station attitude control configuration changes or maneuvers needed for rendezvous, and looks at the trajectory of the incoming spacecraft to determine positioning constraints for any of the articulating appendages such as the robotic arm, solar arrays, or radiators. In most cases, the team needs to feather at least some solar arrays so that plumes

from the thrusters of that vehicle do not hit the wrong part of the array, which could cause structural loading and/or contamination. Arrays that are feathered generally are not producing as much power as normal, so it might be necessary to turn some systems off to preserve margin on the batteries during the rendezvous, as discussed in Chapter 9.

ISS systems are configured for the operation several hours ahead of the vehicle arrival (Figure 10). As much of the systems configuration as possible is done from the ground, but any system that the crew may use during approach will be set up by the crew. Depending on the vehicle, that may include video cameras, the robotic arm system, ship-to-ship communications and monitoring, or simply a still camera used by a crew member at a window facing the right direction. The crew will also prepare the hatchway(s) and pressure check hardware for use after docking.

## Back to Earth

As with any mission, the work does not end just because the crew has made it back to Earth, as seen in Figure 11. Unlike getting the astronauts from Houston to the launch site where the crews take commercial flights to Moscow and then a Russian Space Agency plane to the launch site, getting the crew back to Houston expeditiously is a major operation in itself. It is important to return the crews as quickly as possible to perform postflight medical studies and begin the rehabilitation to Earth's gravity. NASA uses a Gulfstream G3 aircraft to fly the astronauts from Kazakhstan back to Houston (Figure 12). With a range of about 4,200 km (2,600 miles), the G3 cannot make the trip with a single crew due to the long duty day. Hence, it requires two flight crews of three personnel (two pilots and one flight engineer) to handle the long transit time of about 19 hours.



**Figure 11.** The Soyuz is seen as it lands with Expedition 43 Commander Terry Virts of NASA, cosmonaut Anton Shkaplerov of the Russian Federal Space Agency (Roscosmos), and Italian astronaut Samantha Cristoforetti from the European Space Agency near the town of Zhezkazgan, Kazakhstan, on June 11, 2015.



**Figure 12.** The NASA Gulfstream G3 waits on the tarmac in Karagandy, Kazakhstan, in June 2016 to return the Expedition 47 astronauts Timothy Kopra and Tim Peak to Houston for postflight medical studies and rehabilitation.

About 8 days before the crew is expected to land, the first flight crew flies commercial to Europe, usually Scotland or Norway, and waits for the G3 to arrive. The G3 departs Houston with the second crew 4 to 5 days prior to the landing. The two crews swap in Europe, and then the G3 continues to Kazakhstan to await the return of the crew. The crews swap again when the G3 arrives in Europe and the first crew returns on commercial airlines the next day.

Postflight medical evaluations and debriefs with the various specialist teams take up several weeks of the returning crew’s schedules. The crew members are asked about their experience on board with key systems, procedures, payloads, and activities. Their feedback helps the team improve operations and overall support. Just as during flight preparation, this process can include international travel, although as much postflight activity as possible

is planned to take place in the crew member’s home country.

The increment lead flight director schedules a lessons-learned JOP, at which the lead flight controllers discuss issues, gotchas, and process improvements, and watch items for upcoming increments. Major topics

from this discussion roll into a report up to the ISS Program management, where actions may be assigned to track specific issues to resolution before they can impact a future increment team.

Fun, welcome-back events take place, as well. Friends, family, and colleagues may come to Ellington Field in Houston to greet the returning US astronauts, usually within a day of landing. NASA hosts a welcome-home ceremony and presentation by the crew members of memorable slides and videos from their time on board for the personnel (and their families) who supported the mission.

The increment lead flight director and any lead flight directors for major complex ops during the increment have a difficult task at the end of the mission: they have to pick the flight controllers who will “hang the plaque” in Mission Control. This is a time-honored tradition in Houston. A flight controller who distinguished himself or herself through work supporting the mission gets to climb a ladder and hang the

## Terrestrial Challenges Getting Home

After more than 24 trips to return astronauts to Houston, the Aircraft Operations Division within the Flight Operations Directorate has proven to be successful in its mission to get the crews back quickly and safely. However, the flights are rarely routine. Weather can create challenges for pilots, such as delays in departure and en route. Since a relief crew is staged at a particular location, the G3 has to pass through or very near that town. Even the best planning can run afoul, as was the case when the Grímsvötn volcano in Iceland erupted in May 2011 while the G3 was in Kazakhstan awaiting the Soyuz landing. The team had to scramble to move the Europe crew to a location in England, which involved planning new routes at the last minute to complete the missions. NASA replaced the G3 with a G5 aircraft with longer range to eliminate some of these challenges.



**Figure 13.** On February 17, 2016, Operations Support Officer Chelsea Shepherd gets the honor of hanging the plaque for her work during Increment 45. Behind her is lead increment flight director Mike Lammers (center), flanked by astronauts Kjell Lindgren on his left and Kimiya Yui on his right. In the background, Expedition 46 astronauts Scott Kelly (commander, on the right within the screen image), Tim Peake (image center), and Tim Kopra (image left) support the ceremony with a live video link from the ISS.



**Figure 14.** Expedition 19/20 plaque-hanging ceremony in Mission Control on November 5, 2009. Left to right: astronaut Michael Barratt, Lead Flight Director Courtenay McMillan, cosmonaut Gennady Padalka (behind McMillan), Telemetry Information Transfer and Attitude Navigation specialist Andrew Lee, Ground Controller Mitch Venable, astronaut Koichi Wakata, and astronaut Tim Kopra. Lee and Venable jointly hung the Soyuz TMA 14 plaque, as decided by McMillan.

increment or mission plaque. The plaque is the patch design that was developed by the crew and placed by the flight director's console during the increment. This event is typically scheduled when the crew can also attend; the on-board crew via videoconference is tied in to the event. Visitors to Mission Control will see dozens of these plaques hanging in the various flight control rooms. See Figures 13 and 14.

## Conclusion

Each increment takes a great deal of teamwork between the flight controllers and the crew. More than a year before the astronauts fly, a dedicated team of flight controllers led by a flight director begins training the crew and preparing all the operations and procedures that will be needed during that time frame, and provides support as they complete training. Once the crew is launched, the team is responsible for all day-to-day operations. When the time frame is over, the team reviews what worked well and what did not, handing that information to the next team so that the operations continue to improve. The crew and flight controllers get very close, which is important because the crew depends heavily on the ground team. At the end of the increment, an exhausted team hands off to another team. A flight director once compared the process to climbing a mountain: It starts off gradual, then becomes very steep and requires a lot of hard work. Then you reach the summit and are glad you did it. By the time you get back to the bottom, you are ready to do it all over again.



# Chapter 3 **Systems:** Structure and Mechanisms— The International Space Station's Skeleton

**As on Earth, revolutionary research in space often requires a physical laboratory.** Although the International Space Station (ISS) is a state-of-the-art research facility, it is also an outpost in low-Earth orbit that needs to sustain its crew to enable the research being performed. That means designing a space station that provides a shelter where the crew can live in a habitable environment that is protected from the dangerous conditions outside Earth's atmosphere. That shelter needs supporting hardware to provide power, methods for distribution of that power, and computers with software to control all of the equipment. Facilities to support the living quarters and life support equipment inside the laboratory are required, in addition to actual research capabilities and facilities.

These hardware and software systems are described in detail elsewhere in this book. This chapter describes the physical structures of the space station as well as the various methods used for assembling the spacecraft over the course of numerous assembly missions.

## Primary Structure

The exterior of the ISS is made up of multiple modules with a very long truss structure running from side to side, as seen in Figure 1.

The Integrated Truss System—or simply “the truss”—centered atop the US laboratory module, supports eight large solar arrays (see Chapter 9), mechanisms that allow those arrays to track the sun, two large radiator beams (see Chapter 11), and numerous Orbital Replacement Units (ORUs). ORU refers to any unit on the ISS that is designed to be serviced, repaired, or completely replaced.

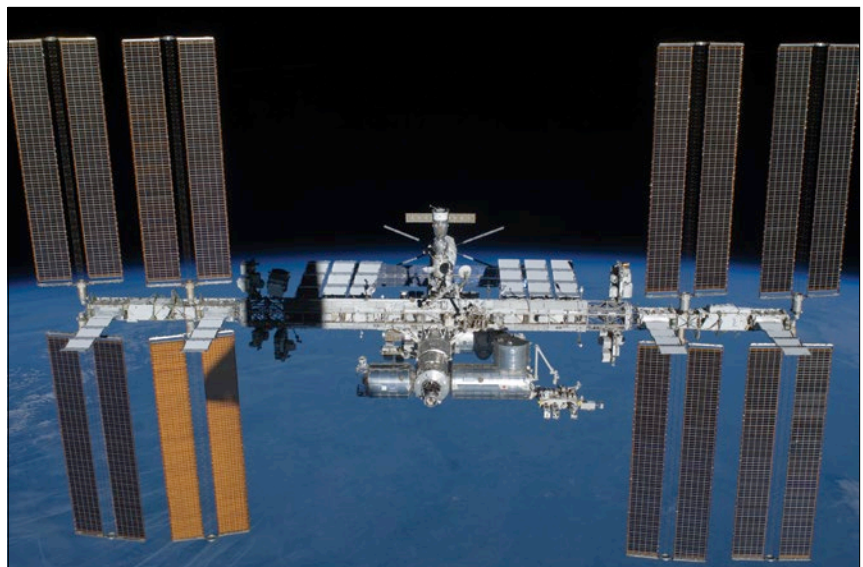


Photo courtesy Ed Van Cise

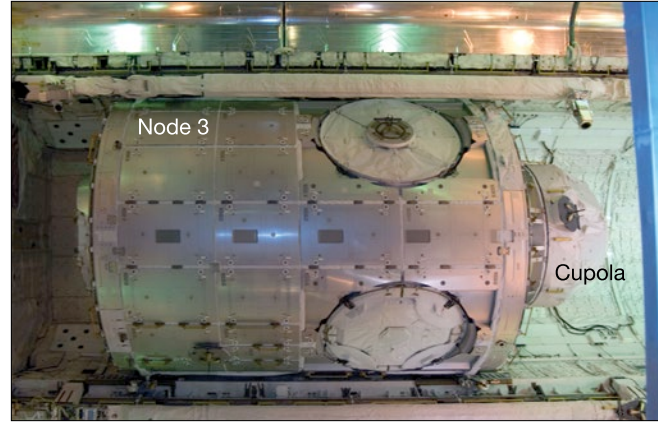
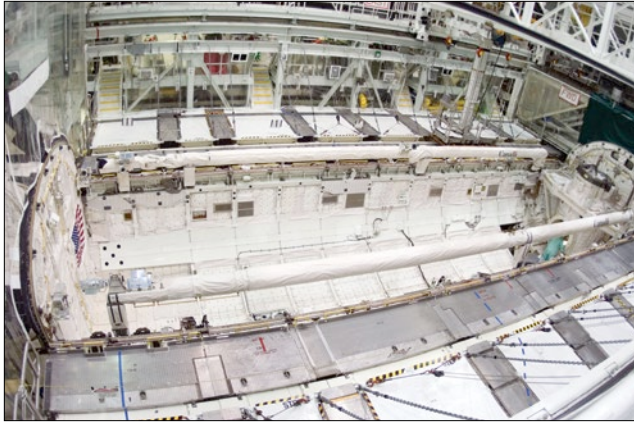
*The Flight Director Class of 2009 (left to right: Scott Stover, Dina Contella, Ed Van Cise) in the Leonardo module as it was being upgraded from a short-duration Multi-Purpose Logistics Module to become the Permanent Multipurpose Module. Numerous elements of the module's structure are visible, including the hatch, rack panels, bulkhead, ducting, and module feedthroughs—all aspects discussed in this chapter.*

The ORUs on the truss include power distribution and conversion devices, Multiplexer/DeMultiplexers (MDMs) (see Chapter 5), pumps,

sensors, and numerous research projects and experiments that need to be exposed directly to the unpressurized space environment.



**Figure 1.** Assembly Complete configuration of the ISS as of July 2011.



**Figure 2.** Left image is the empty payload bay of orbiter Endeavour. The front of the payload bay is to the right where the Orbiter Docking System is installed and two flight deck windows are visible. The payload bay was 4.6 m (15 ft) in diameter and 18 m (60 ft) in length. This meant any cargo in the payload bay could be no larger than a 4.6 m (15 ft) diameter cylinder. The right image is the payload bay configuration for Space Transportation System (STS)-130/ISS-20A with Node 3 and Cupola as the primary cargo. Notice how the cylindrical shape of the module conforms to the shape of the payload bay.

The truss also contains wiring and plumbing to connect all the ORUs.

The Mobile Transporter and the Mobile Base System are mounted to a rail system on the front face of the truss. The Mobile Transporter can be moved to one of eight different worksites along the length of the truss. The space station's robotic arm can be based on the Mobile Base System at any of these worksites. It is this mobility of the arm that enabled the assembly of the station's truss and modules. These systems are covered in more detail in the Chapter 15.

The cylindrical modules of the ISS—be they American, European, Japanese, or Russian—connect to each other to create a pressurized habitat where the crew lives and works in a shirtsleeve environment. The pressure inside the modules is maintained near Earth's sea-level pressure, which is approximately 760 mm Hg (1 atm or 14.7 psi). The pressure outside the modules is essentially zero. That means the module structures must withstand an immense pressure force (760 mm Hg / 14.7 psi) across every facet of its pressure-containing shell. The cylindrical shape of the modules is a strong shape that readily

withstands this pressure. As seen in Figures 2 and 3, this shape also conforms to the shape of the Space Shuttle payload bay (for US Segment modules) and launch vehicle fairings (for Russian modules).

Although the primary purpose of the pressurized modules is to keep the atmosphere in, and thus keep the crew alive, the modules must have feedthroughs to allow fluids (liquid and gas), power, and data to

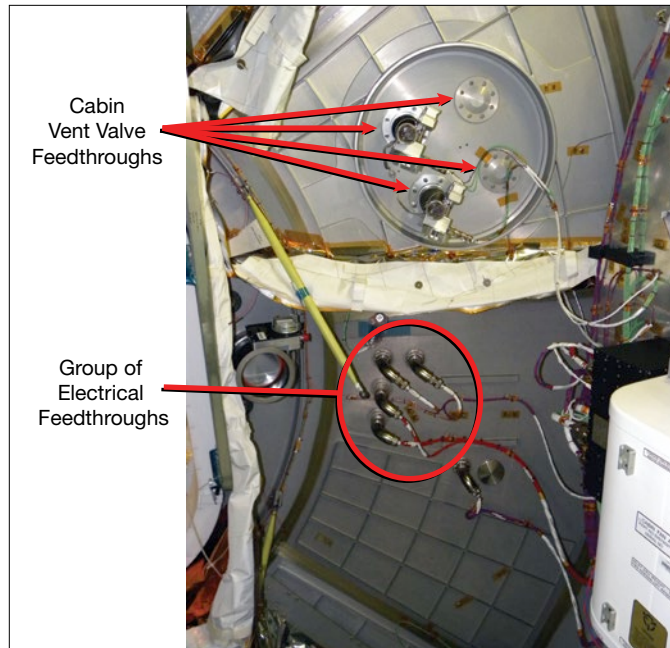


**Figure 3.** The US Laboratory module, Destiny, is supported by a frame that allows it to be rotated as it is being built. The reinforcing ribs that make up a waffle pattern that crisscrosses the primary pressure shell of the module can be seen. These pieces are normally under the orbital debris shielding and thermal insulation that makes each module appear smooth and round (as with Node 3 in Figure 2). This reinforcement is what gives each module enough strength to contain the atmospheric pressure that allows the crews to work in a shirtsleeve environment.

transfer between the inside and the outside (Figure 4). The feedthroughs are designed to ensure the holes in the module have at least two seals to vacuum. Additionally, the internal pieces of each feedthrough are specially sealed and tested to ensure no leaks occur from the cabin out to space through the connector. Every effort was made to minimize the number of items that must cross the pressure shell of the modules to minimize the risk of air leaks.

Hatchways are also feedthroughs that provide a means to get into and out of each module (reference the “Hatches” section of this chapter). Windows provide a means for science experiments to study the Earth, for crew members to view their home planet, and for the operation of a number of educational programs. Windows are essentially large feedthroughs with optical panes installed instead of power or data connectors (reference the “Windows on the World” section of this chapter).

Each of the holes in the primary structure of the modules for these feedthroughs was designed and reviewed for its ability to keep the atmosphere in and keep the crew safe. Each feedthrough is required to have at least two seals to the vacuum of space. Even with these precautions, the ISS crews are trained extensively on how to handle unexpected depressurizations that are either due to a failure in a seal of a module feedthrough or from an impact by orbital debris. Crew members are equipped with emergency response procedures and equipment that they can use to try to pinpoint the leak location and attempt to repair it.

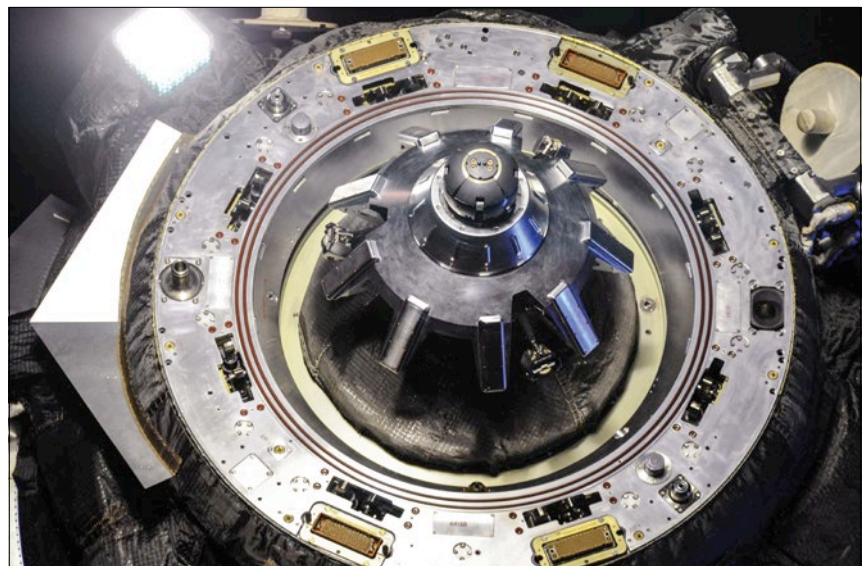


**Figure 4.** The interior of the Permanent Multipurpose Module pressure shell endcone with a number of power, data, and gas feedthroughs. Each electrical feedthrough in this photo is approximately 4 cm (1.5 in.) in diameter.

### Pressurized Module Assembly

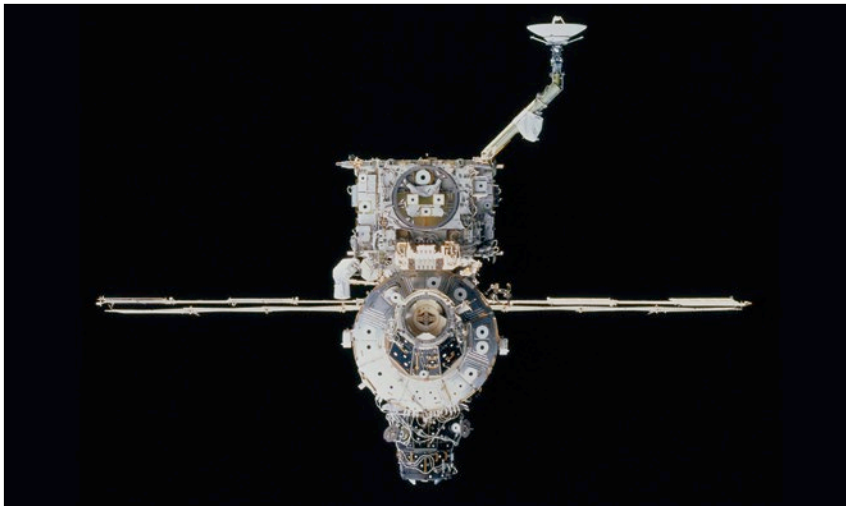
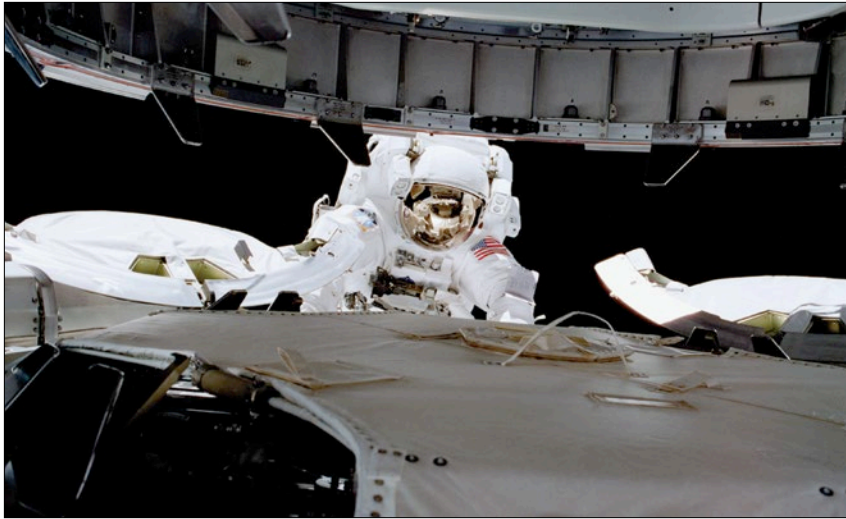
Although the Russian modules of the ISS are all connected using an automated “probe-and-cone” docking

system (Figure 5), this system does not allow for large hatchways that can accommodate transferring large objects, including various payload racks (reference the “Racks” section of this chapter), between modules.



**Figure 5.** The probe docking mechanism of an incoming Progress cargo vehicle. This funnel-shaped probe interfaces with a receiving cone on the docking mechanisms of the Russian segment of the space station. The hatchway that the crew will translate through after docking, which is the space inside the two orange rubber o-rings, is 80 cm (31.5 in.) in diameter.

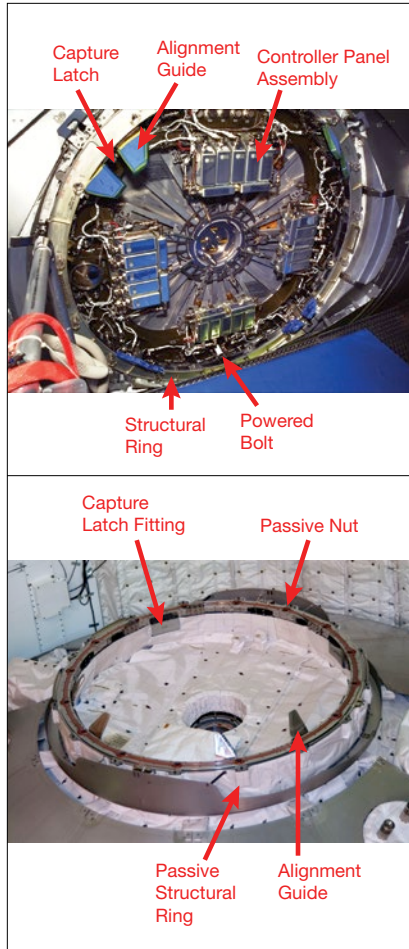




**Figure 6.** Top image: ISS as it appeared to the crew of STS-92/ISS-3A (2000) as they approached the space station. Middle image: The first assembly of ISS components using the CBM. Astronaut Peter J. K. (Jeff) Wisoff monitors as the crew of the orbiter uses the robotic arm to bring the Z1 truss (CBM at the top of the image) toward being ready to be latched by the active CBM of Node 1 (CBM at the bottom of the image). Bottom image: ISS as it appeared to the crew members as they departed the space station. Note that not only was the Z1 truss installed, but also the Pressurized Mating Adapter 3 on to Node 1, opposite the Z1 truss (bottom of Node 1 in this photo).

The hatchways of US Segment modules are larger than the Russian or Space Shuttle hatchways to accommodate the transfer of larger hardware. This larger interface required a different attachment mechanism that would hold the modules together in a way that could withstand larger forces. These forces are greater than those experienced by the Russian or shuttle docking interfaces due to having a larger surface area exposed to vacuum on one side and the sea-level pressures of a shirtsleeve environment on the other side.

As shown in Figures 6 and 7, the Common Berthing Mechanism (CBM) is a complex collection of latches, bolts, Ready to Latch (RTL) indicators (reference the “Finding Ready to Latch” section of this chapter), and computers to control this equipment. This system can be operated by either the ground or the crew; extravehicular activities (EVAs) (i.e., spacewalks) are not required to use this mechanism, unlike some of the truss attachment systems. Once a new module is close enough to the ISS (RTL), four latches on the ISS side (usually a Node module) are used to reach out and “grab” the incoming module and pull it closer. Alignment guides ensure the bolts and nuts of the mechanism are in line with each other. Once the latches have pulled the two halves together, bolts on the active CBM are extended into nuts on the passive CBM. Each of the 16 bolts has a preload of approximately 90 kN (20,230 lbs) of force on it after the bolting sequence is complete. That is the equivalent of having the weight of just over six

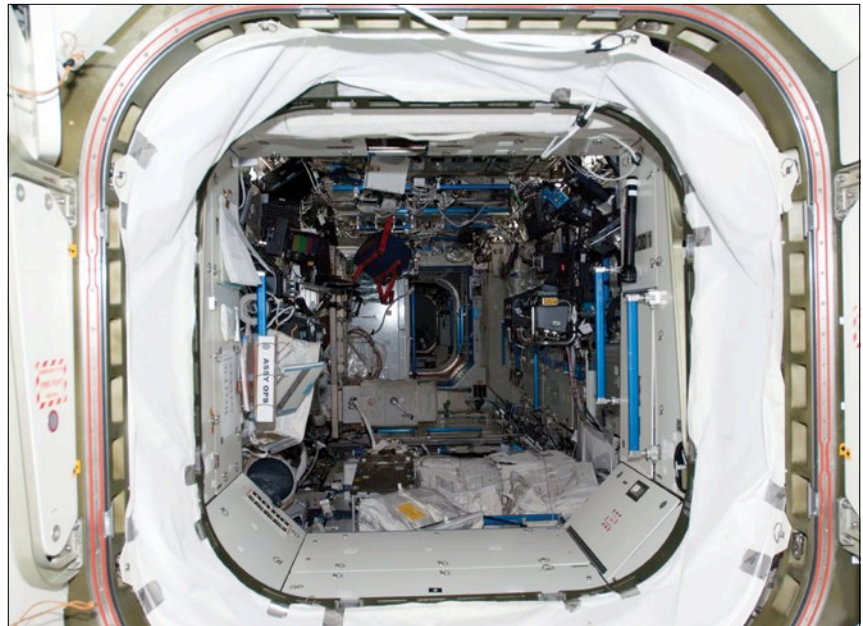


**Figure 7.** Hardware component breakdown of the active (top) and passive (bottom) halves of the CBM. An RTL indicator is situated next to four of the alignment guides on the active CBM (not shown in the figure).

mid-size automobiles stacked on each bolt/nut location. This keeps the three seals between the two halves securely compressed even with the high pressure difference between the ISS cabin and the vacuum of space. Three seal beads on the CBM interface provide fault tolerance. One seal bead can be scratched, leaking, or damaged and the CBM will still have two good barriers between the atmosphere and the vacuum.



**Figure 8.** An example of a vestibule. This is the vestibule between Node 1 and Node 3 on STS-130/ISS-20A (2010) before all the power, data, and fluid jumpers were connected. Power and data cables for the active CBM are still installed (seen floating) but no jumpers are connected yet to the large or small feedthroughs on Node 3 (the module with the closed hatch).



**Figure 9.** The vestibule between Node 1 and Node 3 after it has been fully outfitted and a white cloth closeout barrier has been installed to keep objects from getting trapped or lost inside the vestibule.

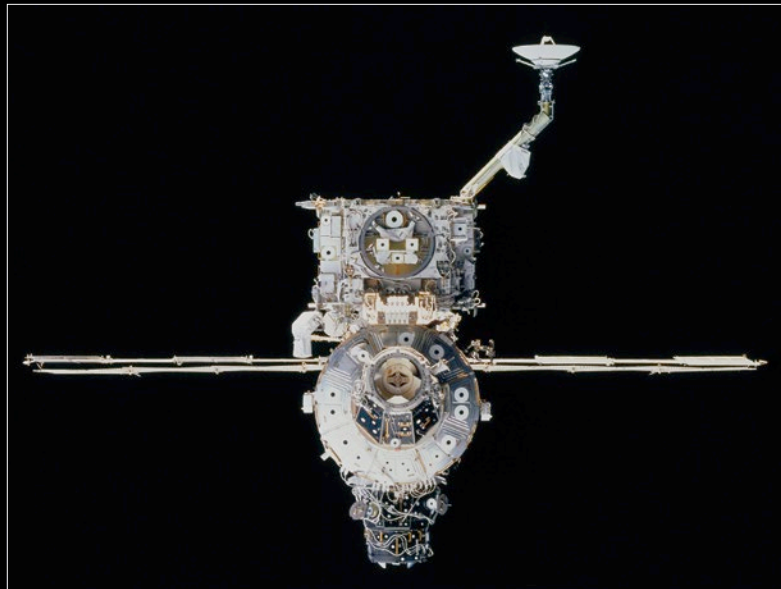
A vestibule is created between the two hatches when the two modules are connected. This is just like a vestibule between two train cars. In this vestibule area, the astronauts connect gas (e.g., oxygen, nitrogen, air), water, data, and electrical lines between the two modules. All of these utilities are connected inside the pressurized area of the vestibule but outside of the hatchway itself. This means the utility lines can be connected without an EVA, but the lines will not run across the open hatchways of the modules. For an example, see Figures 8 and 9. This configuration enables the crew to close the hatches quickly to isolate a module in an emergency, should it be required.

The CBM not only connects the permanent US Segment modules during ISS assembly, it is also used to connect US cargo vehicles (e.g., H-II Transfer Vehicle [HTV], Dragon, and Cygnus) when they arrive. These cargo vehicles use the CBM interface because it provides capability for transfer of both small cargo bags and large hardware such as racks between the cargo vehicle and the ISS. Crewed vehicles use smaller docking systems because large hardware does not need to transfer between the crewed vehicles and the ISS. Docking mechanisms can also release the docked spacecraft faster than vehicles connected by CBM.

Each CBM location can be operated multiple times, if needed. This capability enables cargo vehicles to be attached and detached from CBM locations dedicated to cargo operations. That CBM capability also means that permanent ISS modules can be detached and relocated to alternate CBM locations, if needed.

## The Manual Berthing Mechanism

The early ISS assembly sequence had the Pressurized Mating Adapter (PMA)2 docking adapter on the front of Node 1. The Space Shuttle brought the US Laboratory to the ISS on STS-98/ISS-5A (2000). The orbiter docked to PMA3, located on the bottom (nadir) side of Node 1. The astronauts needed to remove PMA2 from the front of Node 1, put PMA2 somewhere, install the US Laboratory on the front of Node 1, and then put PMA2 on the front of the US Laboratory. To make this happen, an additional CBM location was required to temporarily store PMA2 while the US Laboratory was being installed. This need was realized early in the ISS design development; therefore, a manually operated CBM that used only latches (i.e., the Manual Berthing Mechanism (MBM)) was added to the front side of the Z1 truss (Figure 10). This enabled the astronauts to move PMA2 to this Z1 location and house it there temporarily while the US Laboratory was being installed. The spacewalkers then released PMA2 from the MBM and moved it robotically to the front of the US Laboratory. The MBM, while still in place on the front of the Z1 truss, fulfilled its job during that mission and has not been used since.



**Figure 10.** Photo of the ISS as STS-92/ISS-3A (2000) departed, showing the Z1 truss on top of Node 1 with the large ring of the MBM on the front of the truss. The round and square targets in the middle of the MBM are Space Vision System targets. The Space Vision System is discussed in more detail later in this chapter.

## Truss Assembly

The ISS is not solely a collection of connected cylindrical modules in which the crew can live and work. In addition to these modules, the ISS needs the additional truss structure to support its eight solar arrays, its external radiators, the equipment to run all of those external systems, and a place to mount the large number of science experiments that are running in the space vacuum.

This truss system, often called the “backbone of the ISS,” is attached to the US Laboratory module by 10 struts that connect to the center S0 truss segment. The truss was, of course, not flown up as a single unit. Rather, smaller truss segments were flown up, and the truss was assembled on orbit. As can be seen in the image of the ISS in Figure 1, one side of the truss system appears to be a mirror image of the other side—and that is indeed the case. Not only are the truss segments mirror images, the system hardware installed on the truss is mirrored in many places. For example, for the Port Solar Alpha Rotary Joint, which connects the P3 and P4 trusses (see also Figure 3 in the Introduction and Figure 8 in Chapter 9), to turn in the same direction as the Starboard rotary joint, ground controllers must use commands with values that are the negative of what is sent to the Starboard joint. If this inverse-value commanding were not performed, the two joints would turn in opposite directions because the joints are on opposite sides of the truss but use the same rotary joint control software.

Assembly of some of the truss segments was completed using

only robotic arms and computer commands. The computer-controlled attachment mechanism, known as the Segment-to-Segment Attachment System, connects S0 to S1, S1 to S3, S0 to P1, and P1 to P3. During EVAs, astronauts used handheld power tools to drive the interfacing bolts of the Rocketdyne Truss Attachment System for other truss segment connections, namely the Z1 to P6 (during the early ISS assembly time frame), S4 to S5, S5 to S6, P4 to P5, and P5 to P6 connections (all the connections outboard of the P3/S3 trusses).

The mechanical concept was the same whether an automated mechanism or a manual mechanism was used—four large bolts on one side of the truss segment were driven securely into the receiving nuts of the adjoining truss segment. All of the major truss pieces, all of the large components attached to the trusses (some of which rotate), and all of the hardware within the truss segments are connected through only four bolts/nuts at each truss element interface. This entire truss, which is 109 m (375.5 ft) in length, is connected to the US Laboratory module by 10 attachment struts.

## Structural Health

A primary engineering concern is how loading events can cause the hardware of the ISS to fatigue over time, which may impact how long the engineering teams believe the spacecraft structure can remain in orbit without failing. With the significant mass of the ISS and the loads it experiences being handled across the relatively few connecting points of the truss, engineering

teams need to ensure their ground models of the ISS structural stress and loading match what is actually being experienced by the vehicle. A few of the various loads that the truss must withstand include vibrations from rotating equipment, crews pushing off interior walls, contact with a vehicle that is docking, and thermal expansion and contraction. The ground model comparison is especially important in the assessment on whether the lifetime of the ISS hardware can be certified beyond the original design life expectancy. A number of instrumentation systems have been installed both inside the ISS pressurized modules and externally on the ISS truss. These systems—the Internal Wireless Instrumentation System, the External Wireless Instrumentation System, and the Structural Dynamics Measurement System, along with others—collect engineering data on the stress, strain, dynamics, and accelerations imparted on the ISS structure during various events and stages of ISS assembly and operations. These data are not only useful for improving the accuracy of ground engineering models to help perform analysis for future events such as upcoming vehicle dockings or space station maneuvers, the data are also useful for reconstructing what impact past events may have had on the ISS structure.

For example, in 2009, a misconfiguration of some thruster parameters during a reboost caused the Service Module main engines to pulse at a frequency that was a harmonic with the ISS truss. This essentially meant that the ISS truss, along with the attached ISS modules,

## Why is there no S2 or P2 truss?

The heritage of the ISS design shows up in many different, oftentimes small, ways. One of the larger but perhaps not as obvious instances is with the naming of the truss segments. Although the ISS does not have an S2 truss or a P2 truss, these truss segments were actually in the Space Station Freedom design (the precursor design to the ISS). These truss segments were going to house the thrusters needed to control the attitude and altitude of Freedom. When the Russian Space Agency became an ISS Partner and its modules took the role of housing the thrusters, the S2 and P2 truss elements were no longer needed and were removed from the design. The overall design was far enough along in development that it was decided to not rename the other truss segments.

were flexing and bending at the same time each thruster firing occurred. Each thruster firing then further excited or increased the bending and loads being experienced by the ISS structure. After the reboost, engineers used structural measurement data to assess any damage to the ISS structure (none occurred) and the potential impact to the overall lifetime of the structure (engineers noted a slight, nearly negligible reduction in ISS structural life of some components).

A household example might be akin to having an off-balance load in a clothes washer. In this situation, the washer will “jump around” due to the off-balanced load. This will cause some wear and fatigue on the spinning parts and structure of the washer. A single off-balance event will cause minimal impact or damage to the washer. However, if the washer ran with numerous off-balance loads for long periods of time, the hardware would degrade and the washer would likely break or fail earlier than designed or expected.

## Truss Attachment Sites

Another component of the two truss attachment mechanisms is a capture latch. This component was used in a fashion similar to the latches on the CBM. When a new piece of truss was close enough (i.e., RTL) to the ISS truss, the latch would be used to grab a capture bar on the new truss and draw it closer to the ISS truss. This capture latch can best be pictured as a large claw that would close around that capture bar.

Due to its robust and adaptable function, this capture latch/claw design is used in many other places externally on the ISS. As mentioned previously, a number of science experiments are mounted on the ISS truss. Also, a large number of spare parts are mounted on the truss for use by spacewalkers or the Special Purpose Dexterous Manipulator robot to fix broken external hardware (see Chapter 15). Spare parts and many research experiments are attached to large carrier platforms, either External Stowage Platforms or Expedite the Processing of Experiment to the

Space Station (ExPRESS) Logistics Carriers. These carriers are secured to the truss using a Payload Attachment System (PAS) or an Unpressurized Cargo Common Attachment System (UCCAS). These systems use mechanisms that implement the common capture latch design as well as Umbilical Mating Assemblies (UMAs). The UMAs provide power and data from the ISS to the carrier. Two UCCAS sites are located on the P3 truss, and four PAS sites are located on the S3 truss. Reference Figure 4 in the Introduction to identify the hardware carriers attached to the S3 and P3 trusses on the ISS. In that figure, the Alpha Magnetic Spectrometer telescope is mounted to one of the S3 PAS sites.

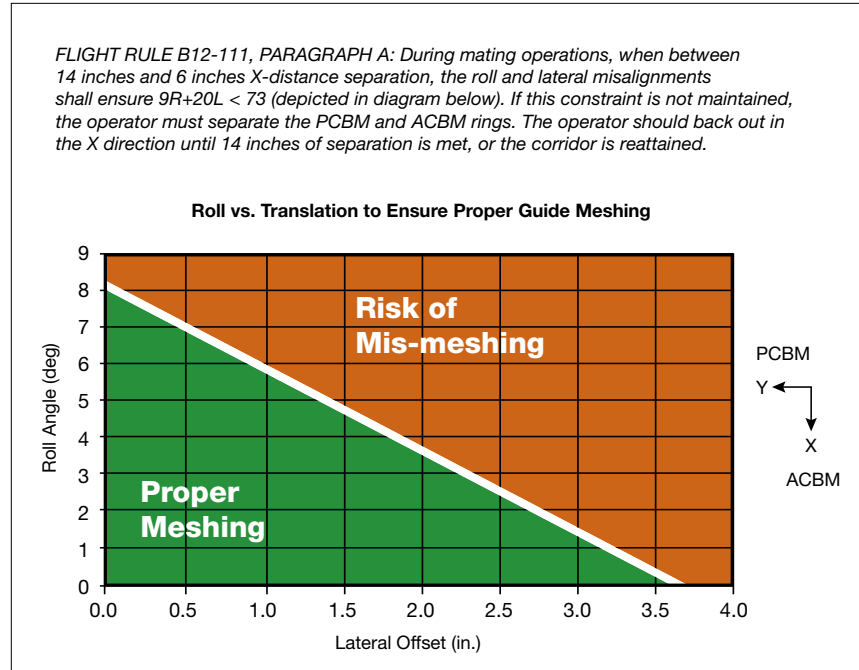
As has been pointed out, the attachment mechanisms of the ISS are required to hold a large amount of mass and withstand significant loading, bending, and vibration. The mechanisms themselves must be very robust and capable to ensure the various designs will perform these functions. Care had to be taken during assembly operations using these mechanisms to make certain that the mechanisms, while actuating latches or bolts, were operated in a specific sequence. This sequence was analyzed prior to the operation to ensure the use, or a failure of a component during that use, would not cause damage to any of the ISS hardware involved (including the robotic arm). This is just one more example where the operations and engineering teams worked closely together to ensure the method of operations planned by the operations teams would stay within the limits analyzed by the engineering teams (often integrated by the End-to-End Berthing Integration Team).

## Finding Ready to Latch

Assembling truss segments and pressurized modules all start with the same requirement—the new component needs to be close enough to its intended mating location to be RTL. The actual RTL indicators look different depending on the mechanism being used, but they perform the same function. The RTLs move when touched by the incoming module/truss. This movement signals to the robotics operators (crew or ground) that the new piece is indeed close enough, and that use of the mechanism can start. An example of this can be seen in Figure 6 (middle). This image from STS-92/ISS-3A (2000) shows the passive CBM of the Z1 truss being robotically brought close to the active CBM of Node 1 Zenith prior to achieving an RTL condition.

The robotics operators need to know how well the new element is positioned with respect to the ISS mechanism prior to the element being at the point of touching the RTLs. Although the trusses and modules are large, very little tolerance for misalignment is allowed between two pieces. The robotics operators must precisely align the incoming element so that it can touch those RTL indicators.

Realizing this critical need for assembly of the ISS in orbit, engineers designed a computer-generated Space Vision System (SVS). The SVS was an optical system that used computer evaluation of camera views to precisely determine the misalignment between the ISS and the new component. Myriad SVS targets—decals with white and black dots (visible in Figure 10)—were installed on modules and truss segments. Prior to launch, the placement of these



**Figure 11.** A portion of Flight Rule B12-111 “CBM Capture (RMS Translation) Corridor Constraints” that explains to the flight controllers how wobble (i.e., a combination of roll and lateral offsets) must be controlled to ensure the CBM halves are properly aligned at the RTL position. Meshing occurs when the CBM halves are separated between 15 cm and 35.5 cm (6 in. and 14 in.). The lateral offset can range between 0 cm and 10 cm (0 in. and 4 in.).

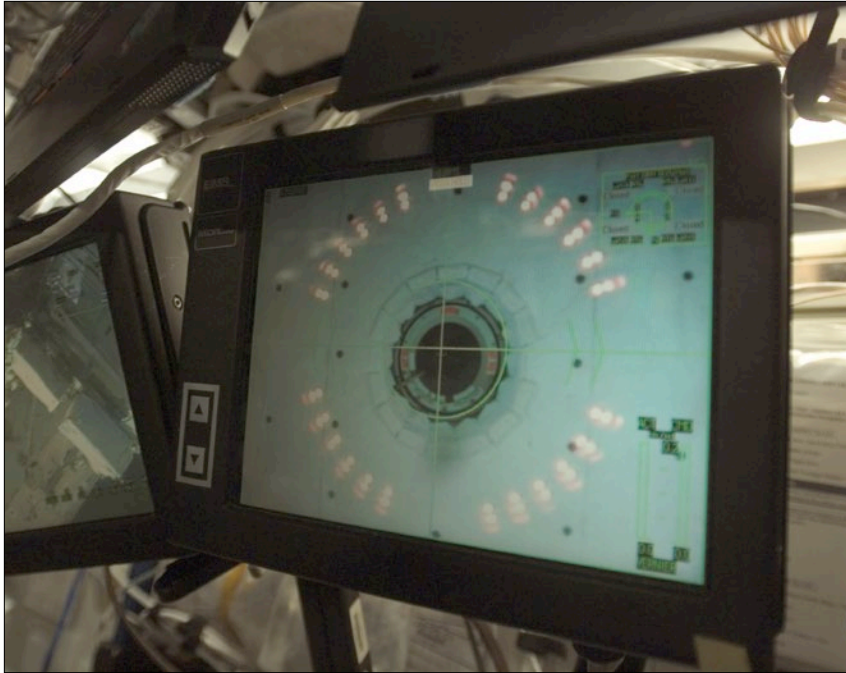
targets was measured precisely with respect to various reference points on the truss/module. This measurement information was loaded into the vision system computers of the robotic arm. These computers, knowing the precise location of the targets, could then use camera views to identify specific targets, precisely compute misalignment information, and provide that information to the operators.

Unfortunately, an SVS solution could only be obtained in orbital daylight (which is roughly 45 minutes or less of every orbit). The SVS was susceptible to losing an acquired solution due to sun reflection off the surfaces of the trusses, modules, or orbiter, or if the targets were obscured by shadows. NASA successfully used the SVS during early stages of ISS assembly;

however, the agency decided soon after the first assembly mission (STS-88/ISS-2A [1998]) that a new “boresight” or centerline camera misalignment system was needed.

Centerline camera systems were not a new concept. The Space Shuttle always used a centerline camera on its docking mechanism window to help crews make final alignments for docking to the Mir space station and to the ISS. Space Station Freedom, a design precursor to the ISS, also included use of a centerline camera mounted on the ISS hatches to view incoming modules through the hatch windows to determine misalignments.

Although the SVS was ultimately selected for use with the ISS in its design phase, the centerline camera was not completely removed from all



**Figure 12.** The view of an incoming module that an astronaut sees on his or her Robotic Workstation monitor from the CBCS camera. Green reference and targeting lines are computer generated by the robotics system and drawn on top of the video image. These lines assist the crew in aligning the new module. The four quadrants of red lights are reflections of light-emitting diodes around the CBCS camera that are used to illuminate the CBCS target on the incoming element. The camera is looking at the hatch window of the incoming module (Node 2 in this case) and the reflective CBCS target mounted around the hatch window (red chevrons).

Freedom design drawings. As many Freedom components were carried into the ISS design with minimal change, the US Segment ISS hatch was the same hatch design as the one originally created for Space Station Freedom. The mounting points for the centerline camera system were not removed from the hatch design in the conversion to the ISS. This meant that when a centerline camera was developed after the Node 1 mission, the hatches already on orbit on Node 1 as well as the hatches on the modules being assembled already had locations in which to mount a centerline camera to the hatch. Thus, the Centerline Berthing Camera System (CBCS)—a cousin to the initial design concept for Space Station Freedom—was rapidly

designed, certified, and implemented to assist in berthing pressurized modules to the ISS.

The CBM is relatively intolerant to misalignments. When the two halves are 35 cm (14 in.) apart, only 5 degrees of wobble and minimal roll and lateral offsets are allowed (Figure 11). When it comes to misalignments, operators are concerned about both translational and rotational errors. Lateral misalignment is the offset in the up-and-down and side-to-side directions relative to the center of the CBM. Rotational errors are measured in roll (twisting about the center of the CBM) and wobble (a combination of pitch-and-yaw errors). By using the CBCS camera, robotics operators who are looking

at a target on the hatch of the new module coupled with a data overlay on the robotics monitor (Figure 12) can detect any misalignments and adjust the position of the module until all misalignments are within limits. The operators can also determine the proximity of the module (the target gets bigger as it gets closer to the camera) and whether it is about to push one of the RTL indicators. CBCS was first used on the STS-98/ISS-5A mission in 2000; the camera was mounted on Node 1 and used to connect the US Laboratory to Node 1. CBCS has been used successfully on every pressurized module installation since that time.

Unfortunately, a CBCS type of system could not be designed swiftly enough to assist in the connection of the ISS truss segments. Instead, those operations relied on the less-user-friendly SVS along with the on-the-scene direction from nearby spacewalking astronauts. With these astronauts in close proximity to the massive truss segments helping guide the installation, special care and choreography was required to ensure the crew was always safely away from the truss connection points and moving hardware.

An External Berthing Camera System (EBCS) was, however, installed on the S3 and P3 trusses. This system is used to assist in installing the cargo carriers to the PAS and UCCAS sites. The targets for this system are installed on the S3 and P3 trusses, and the cameras are installed on the cargo carriers. This is the opposite of the CBCS where the camera is attached to the ISS, and the target is on the new/upcoming hardware. The cameras on the carriers receive their power from the space station's robotic arm

instead of from the truss (Figure 13). This novel approach of putting the cameras on the carrier and the passive target on the truss enabled the EBCS to be implemented on a schedule that would not slow down the fast pace of readying the truss segments for launch and installation.

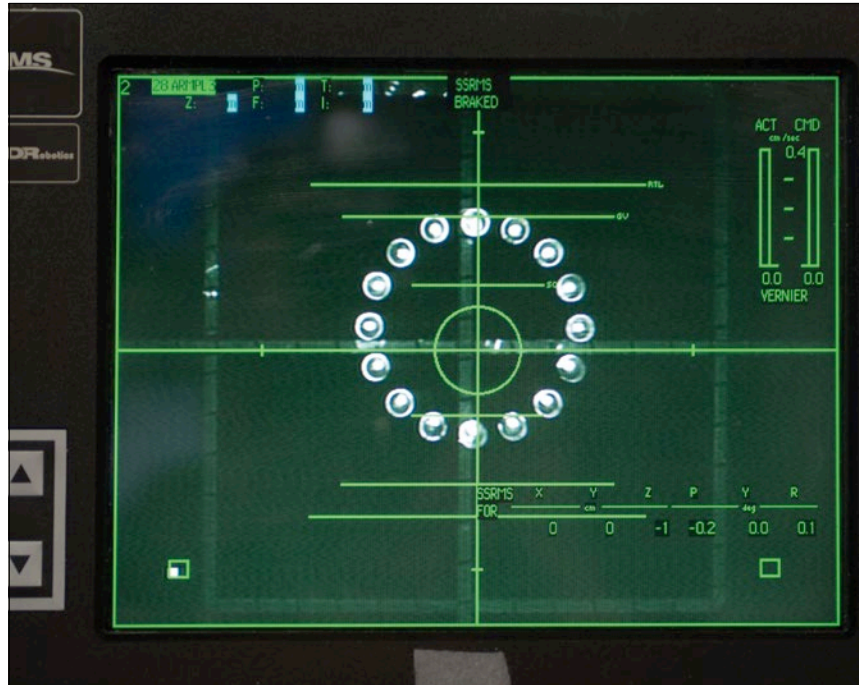
Due to the success of the CBCS and EBCS camera systems, the Japanese HTV cargo vehicle uses a similar HTV Berthing Camera System to assist with inserting its Exposed Pallet (EP) back into HTV after it has been removed from a temporary stowage location on the Japanese Experiment Module (JEM) Exposed Facility.

## Secondary Structure

With the foundation and walls (the primary structure) of the orbiting laboratory built, the ISS needed to be outfitted to actually be able to accomplish its mission. “Secondary structure” provides the means for outfitting the laboratory. The secondary structure is the equivalent of elements such as wallboard, light fixtures, flooring, and major appliances in a home.

## Docking Systems

One of the first necessary pieces of secondary structure is a way for the occupants of the ISS to get into the space station. This means having a method to dock a crewed vehicle. The ISS is outfitted with six docking ports. Four docking ports on the Russian Segment use the Russian probe-and-cone docking system. Visiting Progress cargo ships, crewed Soyuz ships, and the European Automated Transfer Vehicle dock to



**Figure 13.** A photo of a monitor of the ISS robotics workstation during installation of an Expedite the Processing of Experiments to the Space Station (i.e., ExPRESS) Logistics Carrier during the STS-129/ISS-ULF3 mission in 2009. Similar to Figure 12, the monitor shows both a view from the centerline camera as well as a green, digitally drawn graphical overlay. The robotics operators (crew or ground) use the overlay lines to gauge the amount of misalignment between the target (center of the picture) and the camera (ring of light-emitting diodes).

these ports. On the US Segment, the Space Shuttle used a Russian docking system called the Androgynous Peripheral Attachment System (APAS). The Space Shuttle used this system to dock with the Russian Mir space station as well as to the ISS. Whereas the Space Shuttle had the active half of the APAS, the ISS had two docking ports with passive APAS halves. These halves were located on PMA2 and PMA3. After the retirement of the Space Shuttle fleet, the PMAs are being updated to add International Docking Adapter extensions to the passive APAS halves. This will allow future crewed vehicles to use a newer docking mechanism, built off internationally agreed-to standards, to dock to PMA2 and PMA3.

## Shields Up!

One significant concern—in fact, one of the ISS Top Program Risks—is the orbital debris environment in low-Earth orbit. The US Air Force tracks large pieces of space debris (i.e., debris larger than 10 cm [4 in.] in diameter) and the ISS can perform debris-avoidance maneuvers (see Chapter 8) to change its orbit and thereby avoid those objects. The impact of a 10 cm (4 in.) object on the ISS would have an explosive force equivalent of 7 kg (15 lbs) of trinitrotoluene (i.e., TNT). Being able to get out of the way of these large debris pieces is an important part of the overall strategy of ensuring the ISS is not penetrated by orbital debris.



## Really androgynous?

Most mechanisms that involve joining two items together have a side that is active and a side that is passive. The active side has all the hardware that moves and all the computers needed to command and control that moving hardware. That moveable hardware (e.g., latches or bolts) interfaces with non-moving (passive) hardware on the other side of the interface. Examples of passive hardware include nuts, non-moving hooks, latch capture plates, etc. In some mechanisms, both halves have the same moveable hardware. In these cases, one side of the mechanism is designated as active, and its hardware is made to move while the hardware on the other side remains stationary and passive. These roles could be reversed on a subsequent use. This setup for a mechanism is termed an “androgynous” configuration. See Figure 14.

If the APAS were truly androgynous, the system on the ISS PMA or on the orbiter could serve as the active half of the docking system. Although both halves indeed had the same hooks and latches, the active hardware (i.e., motors, controlling computers, pyrotechnic bolts, etc.) was removed from the ISS halves prior to launching the PMAs. That means the orbiter side was always active. The ISS half of the docking mechanism hooks could not be driven, and the explosive bolt pyrotechnics for releasing those hooks were not installed. Should the hooks on the orbiter side have failed to release the ISS, the orbiter side could have pyrotechnically separated its hooks (and, thus, left that docking port permanently unusable). And, if for some reason the pyrotechnics did not work either, a spacewalking astronaut could manually separate the two docking system halves by removing 96 bolts around the perimeter of the docking mechanism. Thankfully, that task was never required.



**Figure 14.** The two androgynous docking system alignment guides are about to overlap, as seen out the orbiter's aft flight deck window just prior to docking on STS-100/ISS-6A (2001).

The orbital debris strategy must, however, also deal with thousands of smaller objects that cannot be tracked and thus cannot be directly avoided. The ISS modules—US Segment, Russian Segment, and all temporary crew and cargo vehicles—are designed to protect against the impact of very small (1 cm [0.4 in.] diameter or smaller) debris. This protection comes via another secondary structure component, debris shielding, which is described in more detail in this section.

Debris too small to be tracked but still too big to be assuredly stopped by debris shielding could penetrate the ISS shields and pressure shell. The ISS crews are trained extensively on how to respond to rapid cabin depressurizations due to midsize orbital debris penetrations, should one ever occur. In these scenarios, crew members first remove themselves from the immediate area of impact, ensure their rescue vehicles are not leaking, and work to isolate the module with the leak by closing various module hatches.

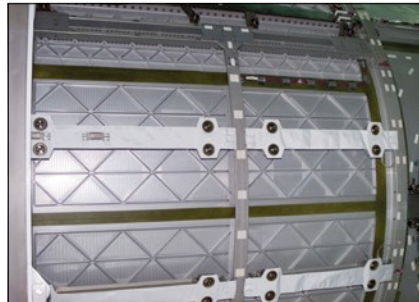
In the event a piece of debris penetrates the pressure shell of the ISS, on-board tools and repair kits help the crew pinpoint the leak/penetration point (which could be a very small hole, numerous small holes, or a larger gash) and attempt to repair the damage. Current on-board repair kits should allow the crew to repair holes up to 1.25 cm (0.5 in.) in diameter, assuming enough reserve time is available to find and repair the leak. Reserve time is the calculated time remaining before the cabin pressure drops below 490 mm Hg (9.5 psi). Once the pressure drops that low, crew members must isolate and seal off the leaking compartment (if the location is known) or isolate

themselves in their return vehicle and prepare for possible departure from the ISS. To provide some time margin, the crew is trained to seal off a leaking compartment with 10 minutes of reserve time remaining.

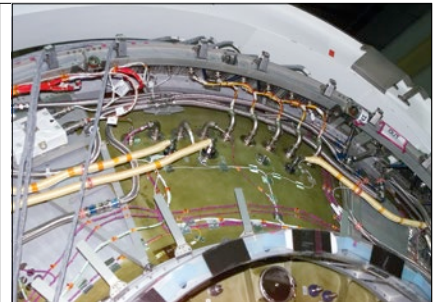
Research efforts to develop the best possible methods for mitigating the risks and damage from debris impacts have been ongoing for as long as humans have been flying objects in space. This research has been conducted within NASA, academia, industry, and internationally. The potential outcome from debris impacts puts risk on uncrewed satellites as well as human-tended spacecraft. For the ISS, the placement and type of debris shielding varies depending on the location of the area being shielded and the duration of time that module is on orbit. This is all factored into an engineering calculation called the Probability of No Penetration. For more details on the ISS Program response to the Micrometeoroid and Orbital Debris (MMOD) risk, reference the 2012 Aerospace Safety Advisory Panel Report at <http://oiir.hq.nasa.gov/asap/reports.html>.

Most US Segment debris shielding employs hard aluminum panels mounted atop the primary pressure shell of the module. The thickness and placement of debris shields are based on the Probability of No Penetration. Shields that will face forward—i.e., the direction in which the ISS is flying for most operations—are generally thicker since these areas have the higher probability of being hit by debris.

The panels of the US Segment debris shields are separated from the pressure shell to create a gap between the panel and the shell. This gap serves two purposes. First, numerous



*Node 2 module pressure shell. The final barrier between debris and the internal pressurized cabin. Note the waffle pattern on the aluminum cylinder that helps increase the strength of the shell, and the large longitudinal rings that create barrel sections of the cylinder.*



*Generally, a number of wire harnesses for power or data, or fluid lines run outside the pressure shell but underneath the MMOD shields and insulation. Shown are some of the wires running underneath MMOD shields of the Node 2 module.*



*Once all the equipment that needs to be attached to the pressure shell or run under the insulation blankets is installed, the blankets themselves are installed. These blankets are a thick composition made of materials such as Nextel® and Kevlar®. These materials not only insulate the pressure shell, they serve as another debris barrier where MMOD energy is dissipated and debris is broken into smaller fragments. This photo shows some of the MLI blankets on the Joint Airlock.*



*Once the MLI blankets are installed, the MMOD shields can be installed. Some equipment, such as these EVA handrails on Node 2, are also installed onto the outside of the shields. The shields are designed to be easily removable by spacewalking astronauts to access the equipment under the shields and MLI blankets.*

**Figure 15.** *The debris shielding of the Node 2 module starting at the top left with the pressure shell, followed (top right) with various wire harness, followed (bottom left) by insulation materials, and finally (bottom right) the outer debris shield panel.*

utility lines and other hardware that do not need to be in the pressurized environment are underneath these panels. This protects them from exposure to the atomic oxygen of the low-Earth orbit environment and also protects them to some degree from orbital debris. Second, a layer of tough, insulating material called Multilayer Insulation (MLI) is placed between the debris panels and the

pressure shell. This provides another debris barrier and thermal insulation for the pressure shell. Figure 15 shows the build-up of this type of debris shielding.

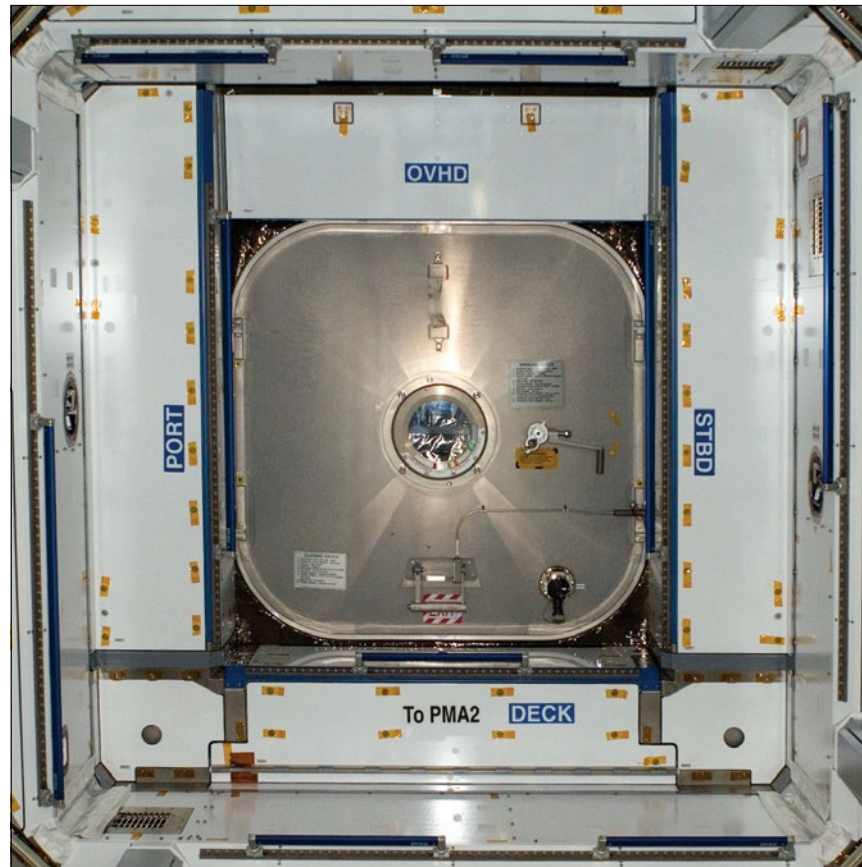
This shielding setup is a Stuffed Whipple Shield design. When a piece of debris strikes the debris panel, some debris is stopped at that point since it does not have enough energy to penetrate the shielding.

Some debris with higher energy will penetrate the shielding. The debris will lose energy and fracture into multiple smaller pieces. These pieces will travel through the insulation material, which will cause the debris fragments to continue to lose energy and spread out from the point of penetration. Debris that started smaller than 1 cm will either not make it to the primary pressure shell, or will strike the pressure shell but not penetrate.

Other areas of the ISS where the likelihood of debris strikes and penetration are lower, or areas that are not habitable by the crew, may be protected only by thick insulating blankets. This is true for many areas of the Russian Segment, especially the shorter-duration Soyuz and Progress vehicles. For this shielding, the blanket properties and thickness are such that the debris will be stopped prior to penetrating the pressure shell.

## Hatches

As mentioned previously, one of the larger feedthroughs in any module is the hatchway. These hatchways enable crew and cargo to pass between modules. Each module has a hatch to close off each hatchway vestibule for each module to remain pressurized before it is attached to the ISS, and to allow for the isolation of the modules in the event of a depressurization or contaminated atmosphere. The US Common Hatches are 1.2 m (50 in.) square in size (Figures 16 and 17). The hatch system is designed such that when the hatch is closed, the force of the internal module air pressure pushes the hatch against the bulkhead seals of the module and



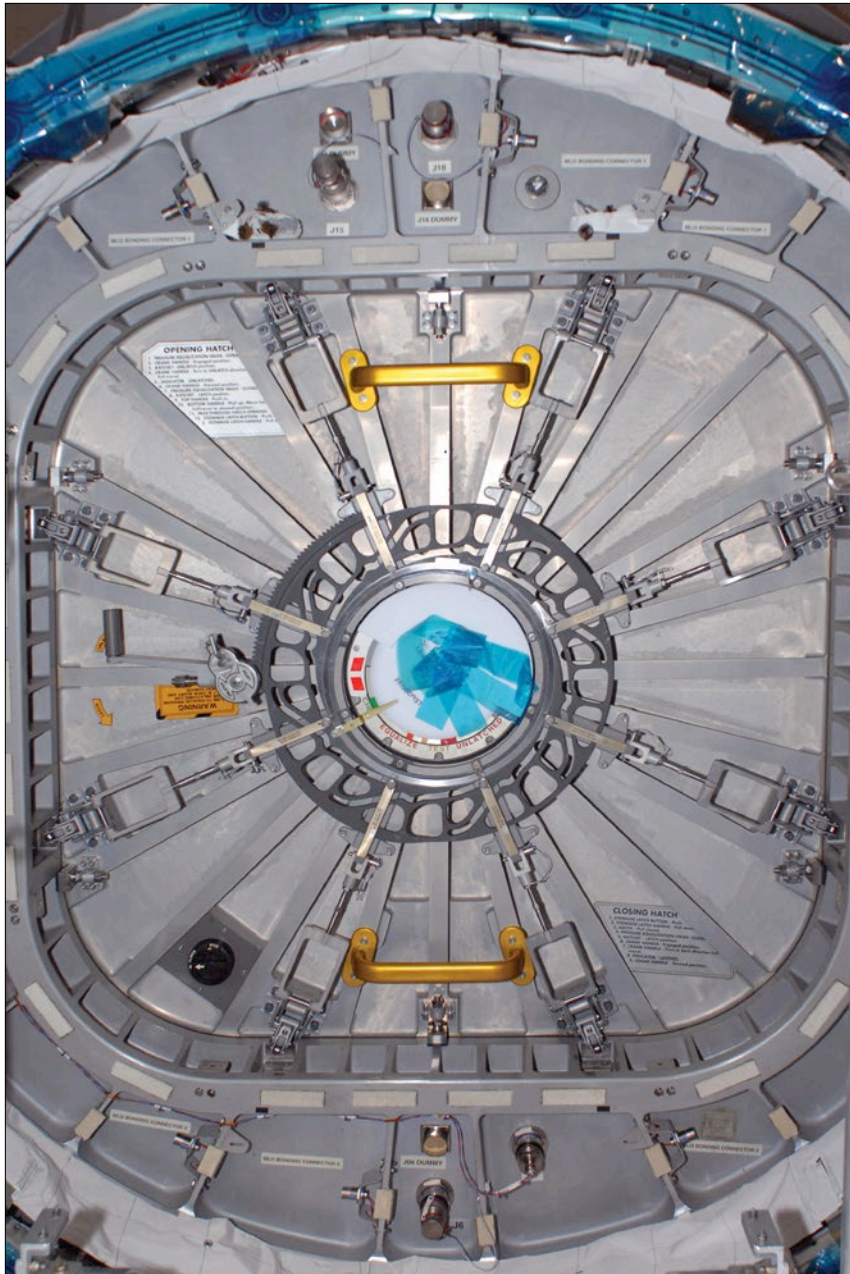
**Figure 16.** The smooth internal side of a US Common Hatch. This side faces into each module. Note the handle in the center right that the crew turns to latch or unlatch the hatch, a deployable handle at the bottom center to engage or release the hatch from its stowed position, a valve in the bottom right corner of the hatch used to equalize the pressure between the two sides of the hatch prior to opening the hatch, and a window in the center of the hatch.

provides the sealing force. Latches are included on the hatches, but these latches are only needed to ensure the hatch is aligned with the bulkhead and pulled close enough to the module such that the air pressure can provide the sealing force. The latch mechanisms also have a component called a “kicker” that pushes against the module bulkhead when the hatch is unlatched to help push the hatch off the bulkhead.

The round hatches of the Russian Segment modules are 80 cm (31.5 in.) in diameter. This includes the hatches between module vestibules as well as

hatches between modules and docked vehicles (i.e., Progress, Soyuz, or Automated Transfer Vehicle). The hatches on PMAs 1, 2, and 3 are also 80 cm (31.5 in.) in diameter, based on the Russian hatch design.

Additional hatches on the ISS include the inner and outer hatches on the Japanese Airlock and the outer egress hatch of the Joint Airlock. The EV (for extravehicular) hatch on the Joint Airlock is the same Shuttle B-type hatch that was found on the airlock of the orbiter. This is due to the fact that the Crewlock portion of the Joint Airlock is actually an exact duplicate



**Figure 17.** The external side of the Permanent Multipurpose Module hatch prior to launch. The actual hatch mechanisms and linkages are all on this side of the hatch—the side that faces space vacuum. Note that both the internal side and the external side of the hatch have crank handles; the hatches can be opened or closed from either side of the hatch.

of the orbiter airlock. The Crewlock is attached to the larger Equipment Lock of the airlock. A US Common Hatch at the Equipment Lock/

Crewlock interface allows only the Crewlock to be depressurized when crews go on EVAs (see Chapter 17).

## Windows on the World

The ISS has numerous windows. These windows are large feedthroughs that run the risk of leaking; the large, fragile panes of glass could easily be damaged by orbital debris. It stands to reason that the occupants of the Earth-orbiting outpost would want to be able to see the planet. Although the windows enable crew members to look down at their home, sightseeing is far from the primary purpose for those windows. In fact, the windows on the ISS are positioned primarily for scientific research and educational purposes as well as for enabling the crew to have situational awareness of the space immediately around the space station during EVAs and robotic operations, and during the approach or departure of visiting vehicles.

The Service Module alone has 12 windows, most of which are Earth facing. Other Russian Segment modules contain a number of windows, as well. Each US Segment hatch also has a window, although most windows on closed hatches are usually covered by a protective blanket on the outside or by stowage bags on the inside, meaning that the crew rarely uses the hatch windows for viewing. The primary purpose of the hatch windows is to view incoming modules (reference the “Finding Ready to Latch” section of this chapter). Thus, an external flap is left closed over the window to protect it from orbital debris until a hatchway is intended to be connected to a new module. Hatchways are also highly convenient locations inside the ISS where crews can temporarily stow hardware that might be staged for an upcoming cargo vehicle. This



**Figure 18.** “The ‘Cupola’, attached to the nadir side of the space station, gives a panoramic view of our beautiful planet,” said Expedition 25 Commander Doug Wheelock (shown in photo) about this module that has seven large windows.

staged hardware usually covers the window of that particular hatch.

That leaves three primary window locations for viewing events outside the US Segment of the ISS for research, educational events, or crew viewing and photography. The US Laboratory has a single, large-diameter window (Figures 19-21). Research experiments are mounted into the Window Observation Rack Facility, which is installed over the top of this window, thus enabling detailed observations of Earth. The JEM has two large-diameter windows on its port bulkhead; these windows are used to monitor operations of the JEM robotic arm, activities on the

JEM Exposed Facility, and operations of the JEM Airlock. The Cupola is a module of windows attached to the bottom of Node 3 (Figure 18). It has one large, round window at its center and six trapezoidal windows around its perimeter to provide a breathtaking bay-window view of Earth. The Cupola is used by the crew not only for Earth viewing, but also to monitor the arrival and departure of visiting vehicles as well as EVAs and robotics occurring on the bottom of the ISS.

The Earth-facing science window in the US Laboratory was specially designed and manufactured to support scientific investigations. This was accomplished through specific and

fine polishing specifications, and through application of coatings on the glass surfaces (as well as specific decisions on which coatings to leave off the window). This detail on the US Laboratory window enables excellent optical qualities that allow the use of various cameras and telescopes that operate in both the visible and non-visible light wavelengths. The windows in the Laboratory, JEM, and Cupola, as well as many of the windows in the Service Module, are also protected with shutters to ensure as little debris as possible makes its way onto the high-quality optical glass. These shutters—some manually controlled

## How big are the windows?

Size (diameter) of common ISS windows:

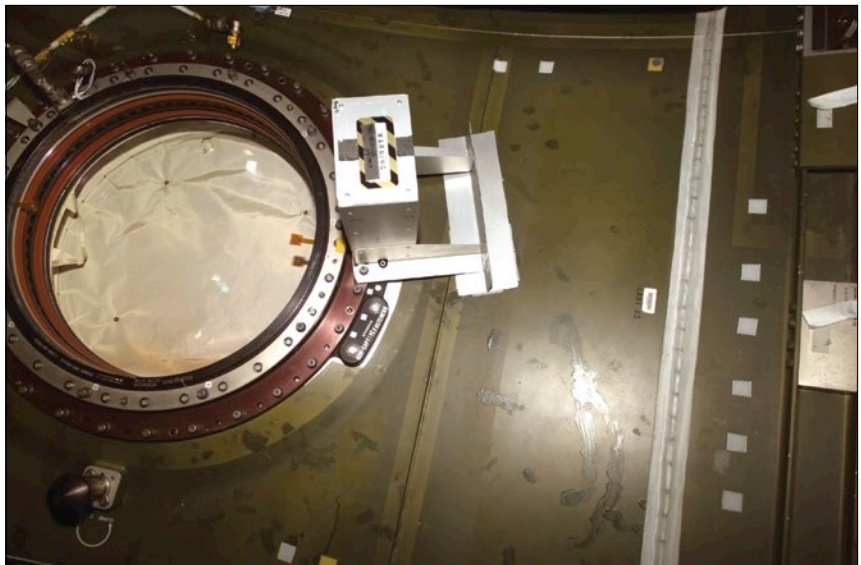
- US hatch: 20.3 cm (8 in.)
- US Laboratory: 51 cm (20 in.)
- JEM (two): 51 cm (20 in.)
- Cupola center: 70.6 cm (27.8 in.)
- Cupola trapezoidal (six): 0.2<sup>2</sup> m area (322 in<sup>2</sup>)
- Service Module Window #9: 48.3 cm (19 in.)

and some electrically controlled—serve to reduce the exposure of the outer window pane to contamination from jet firings or material off-gassing, provide debris shielding for that outer pane, and block sunlight from entering the ISS cabin.

None of the windows on the ISS are composed of a single pane of glass, nor is each pane as thin as one found in a home window. Rather, two panes of relatively thick glass maintain the pressure integrity of the module and, typically, there are additional thinner protective panes on the inside and outside of the window. That makes for a total of four panes. The inner protective pane (called the “scratch pane,” as it is intended to prevent the crews from inadvertently scratching the glass pressure pane) can be removed if necessary. A vacuum is drawn on the inter-pane space to prevent condensation from forming between the two panes of window



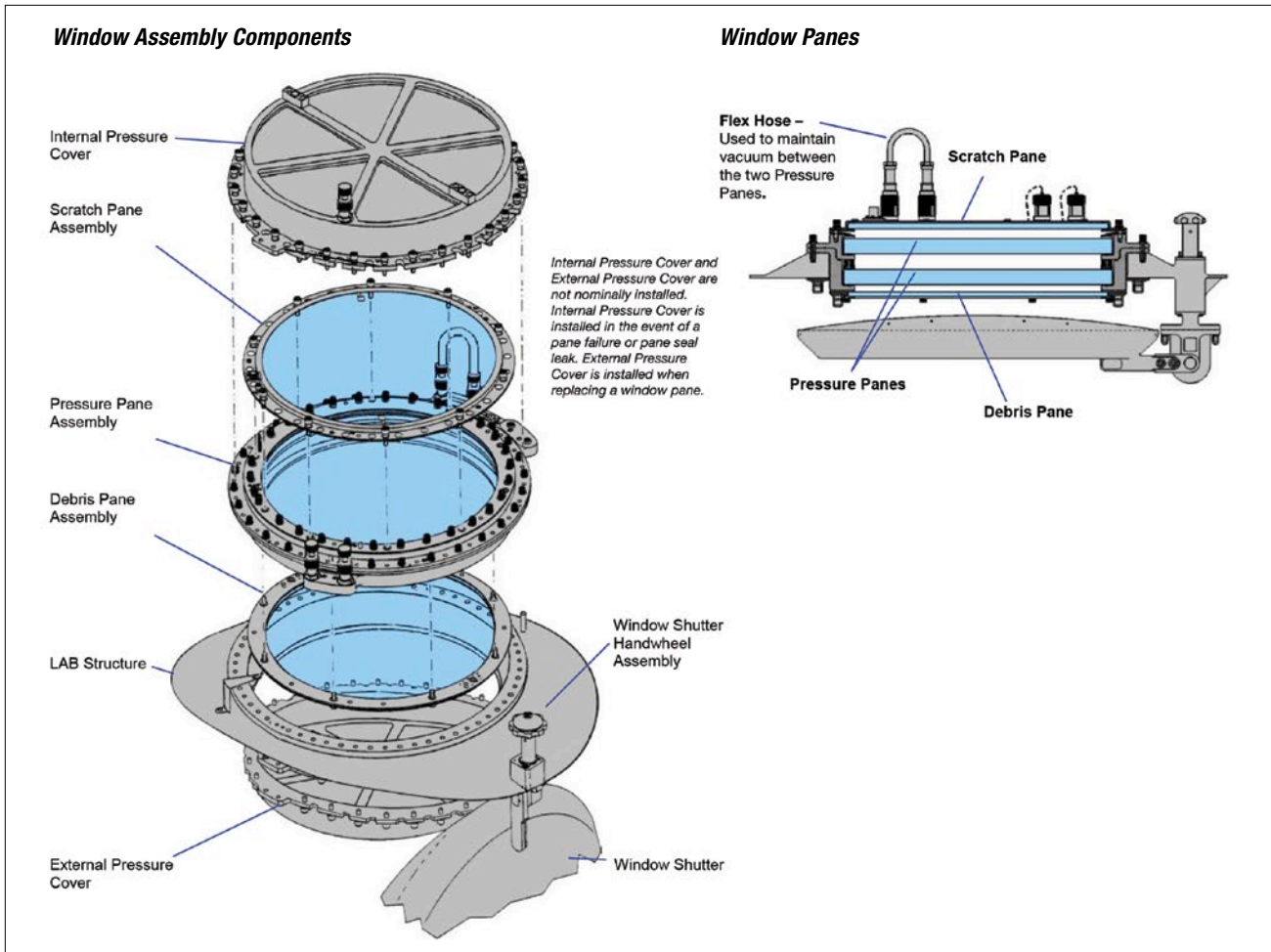
**Figure 19.** Expedition 8 Commander Mike Foale using the Ultrasonic Leak Detector in 2004 to pinpoint a small leak that had developed in one of the seals of the hose used to maintain a vacuum between the panes of glass within the large window of the US Laboratory. Once the leak point was identified, the hose was disconnected (which stopped the leak to space) until a replacement hose could be flown to the space station.



**Figure 20.** The US Laboratory window with its shutter closed (noted by white cover visible through the window) and protective box covering its vacuum flex hose. Clockwise from the box is the handwheel crews use to open and close the shutter.

glass. That is the purpose of the flex hose that Mike Foale is inspecting in Figure 19. That flex hose also proved to be an inviting hand hold for early ISS crew members; over time, this resulted in the development of a

small leak in that hose. A protective box has now been installed over these flex hoses to ensure they do not get bumped and start leaking, as shown in Figure 20.



**Figure 21.** Overview of the US Laboratory window. Note that the flex hose was the source of the leak discussed in Chapter 16.

The design concept of these windows is that any high-velocity debris would hit the outermost debris pane, followed by the outer pressure pane. If the debris were going fast enough to break through both panes, the particles would be slowed enough such that they would not penetrate the inner pressure pane. As shown in the diagram in Figure 21, this design is similar to the Whipple Shield design of the module debris shields described earlier. The smaller windows on the ISS, such as the US hatch windows, have the same dual-pressure pane design concept as well as inner and outer protective covers.

The windows of the US hatches, US Laboratory, JEM, and Cupola are designed to be replaceable in the event a window pane breaks. An astronaut would install an external pressure cover over the window, via an EVA, to replace the windows exposed to space. The window would then be removed from the inside of the ISS. The windows themselves cannot be removed by a spacewalking astronaut; the removal must be done from the pressurized environment of the ISS cabin. Thus, if debris were to damage both panes of a window and cause a module to depressurize, it would not be possible to replace that damaged

window. Instead, the crew would install the external pressure cover, via EVA, and repressurize the evacuated module. The crew could then go into that module and remove the window.

With the window removed, the crew would install an internal pressure cover over the window's hole until the new window was ready to be installed. The pressure covers are on orbit to provide a means to respond to a broken window pane; however, no spare windows are kept on board the ISS. A spare would need to be manufactured and flown after the failure.

## Racks

With a pressure shell, protective debris shielding, and windows in place, it is time to discuss a piece of the ISS modules with which crews interact on a continual basis. In the US Segment, the cylindrical modules are broken up into four quadrants. For each module, there is a floor (“deck”), ceiling (“overhead”), a left side (“port”), and a right side (“starboard”). An empty square-shaped space runs the length of the center of each module; this is where

the crews live and work (Figure 22). A series of racks separate the pressure shell from the crews’ living and working space.

The numerous types of racks on the ISS can be broken down into four major categories. The avionics racks contain the computers, fans, power converters, air conditioners, etc. that are required to keep the vehicle functioning and the crew alive. Payload racks house the various science facilities and experiments that are conducted. Crew support racks

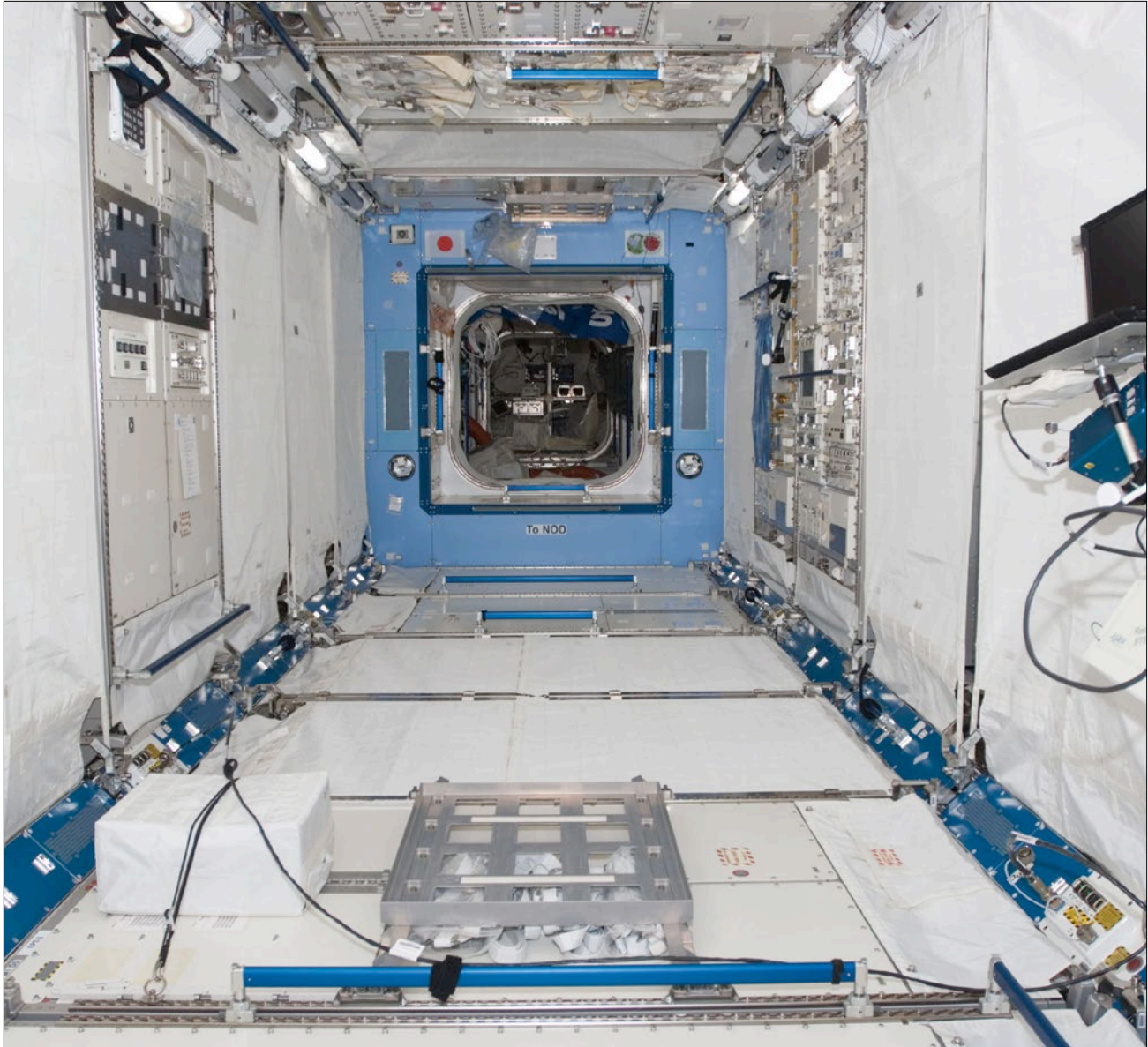
contain items such as the galley, food refrigerators, food warmers, and the toilet. (See Figures 23 through 28.) Finally, there are stowage racks.

Given that stowage space is at a premium on the ISS, the crew can find stowage spaces not only in dedicated stowage racks but also in various compartments in all the other racks. Stowage space is also found in standoff areas, endcones, hatchways, and pretty much any other nook and cranny that may not have an alternate dedicated use.



**Figure 22.** Cosmonaut Sergei Krikalev, flight engineer for the Expedition 1 crew, floats in the US Laboratory shortly after it was installed on STS-98/ISS-5A (2000). The four walls are actually the front faces of different racks. Note the empty central corridor. This photo was taken before the numerous science racks were launched and installed in the Laboratory.





**Figure 23.** A view of the JEM from its Airlock looking starboard toward Node 2 and Columbus. The camera taking this photo would be in Bay 7 of the JPM. The JPM1F2 location would be the second rack bay from the hatch on the forward wall (which is to the left in this picture). That means it would be the rack bay covered by the white fabric panel on the left side of the image, second rack bay from the blue wall/hatchway.

The rack concept for the US Segment harkens to similar concepts in use in laboratories and research facilities on Earth. Using standard interfaces—i.e., interfaces between rack and module as well as those inside each rack—allow for

relatively simple and straightforward interchangeability of avionics and research experiments throughout the US Segment. Each rack on the ISS is held to the structure of its ISS module by four points—one at each corner of the front of the

rack. As shown in Figure 23, spaces exist between the top of one rack and the bottom of the next. Lights, ventilation grids, power outlets, and other equipment are installed in these areas of each module. These standoff areas are also where the racks



**Figure 24.** Astronauts Ken Ham (top), STS-124 pilot, and Greg Chamitoff, Expedition 17 flight engineer, install various racks in the JEM module after it was attached to the ISS on STS-124/ISS-1J (2008). Some of the racks were launched in one location due to orbiter center of gravity requirements and needed to be moved to their final locations after the module was attached to the ISS.

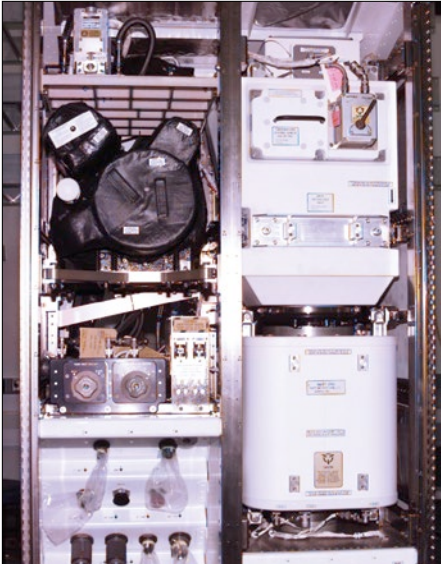
attach to the module. Pivot pins are installed at the bottom of the rack. This configuration allows the crew to detach the two attachments at the top of the rack and rotate the rack on its two pivot pins. This gives the crew generally simple access to the back of the rack and to the pressure shell of the module. This easy access is important in the event the crew needs to look for hull penetrations caused by orbital debris.

Of course there is no “up” or “down” in zero gravity, so how do the crews remain properly oriented? All of

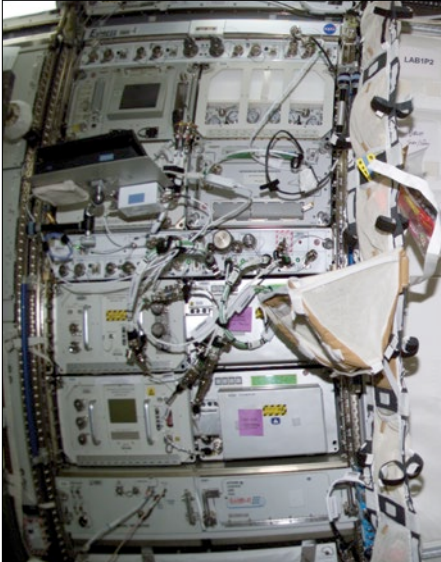
the lights within the module are overhead and the air return grilles are on the deck. The walls are port, starboard, forward, or aft, depending on where the module is located on the ISS. (This system works well for horizontal modules but can still be confusing in the vertical modules such as visiting cargo vehicles.) When dealing specifically with a rack, all references are made with respect to the crew member facing the rack with his or her feet being toward the pivot brackets. That way, the crew member always knows where the top of the rack is located.

It can still be confusing to find places inside the ISS because it is so large. For that reason, the ISS as a whole has a common location coding scheme. The system for identifying a location inside a pressurized module includes the name of the module, the rack bay, the particular rack in that bay, and even a locker within that rack.

For example, the location code JPM1F2\_D1 would be Japanese Pressurized Module (JPM)1 (i.e., JPM1—commonly called the JEM), Forward 2 (second rack bay from



**Figure 25.** An example of an avionics rack. This is the Moderate Temperature Thermal Control System rack (see Chapter 11) in the US Laboratory with its closeout panels removed, prior to it being installed at the LAB1S6 location. On the left side of this rack is a fluid pump that is covered by black insulation. On the right half of this rack is a heat exchanger (top half) and cabin fan (bottom half) that, together, make up one of the Laboratory's air-conditioning systems.



**Figure 26.** A payload rack, Expedite the Processing of Experiments to the Space Station (ExPRESS) 4, in the US Laboratory module during Expedition 4 (2002) prior to it being relocated to the JEM. An ExPRESS rack has a number of locker locations where smaller payloads can be installed; these payloads can get power and data from the central area of the rack. The smaller locker payloads can be exchanged regularly, and can even be returned to the ground, if necessary.



**Figure 27.** The Waste and Hygiene Compartment (WHC), located at NOD3F4, is an example of a rack designed for crew support. The WHC is the bathroom for the US Segment. To use this facility, crew members close a privacy curtain (located approximately where the camera was located to take this photo). Liquid waste enters a funnel at the end of the hose, as seen in the upper-right corner of the above image. Solid waste goes into the solid waste receptacle (metal can), as seen in the middle of the image. Liquids and solids are drawn into their respective destinations by airflow from a fan that runs when the WHC is powered on.

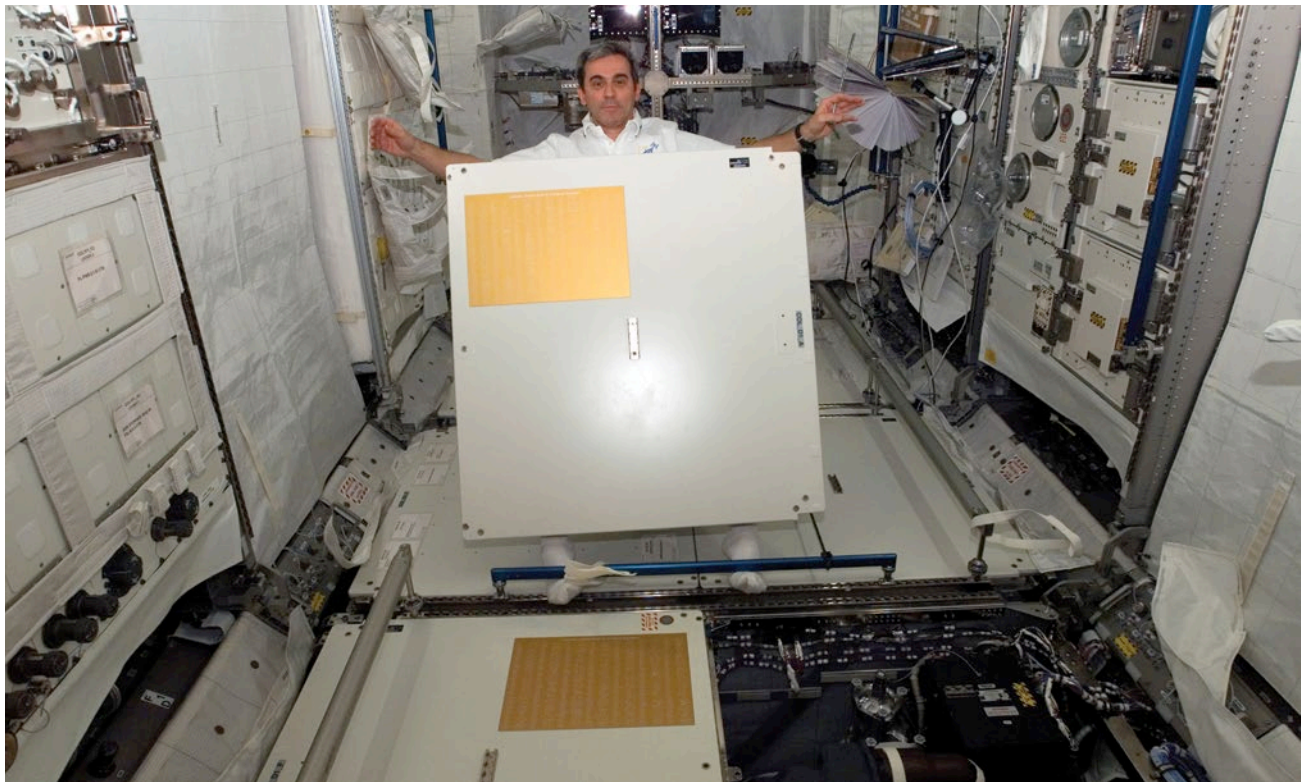


**Figure 28.** The Fluids Integrated Rack (FIR) at LAB1S4 is an example of a payload facility rack. Here, Expedition 29 Commander Mike Fossum works on an experiment inside the glove box that is part of the FIR rack (2011).

the center of the ISS, the rack on the forward wall of that rack bay), locker D1 (a label is located on each locker location; A and B are at the top of the rack). This common location coding system is also used as part of the Inventory Management System, thus enabling all equipment on the ISS to be tracked to a specific location.

### Closeouts

Many of the racks and standoffs have closeout panels installed to keep the ISS looking nice, to avoid numerous open holes and places for items to get lost, to aid proper airflow through the station, and to aid in fire suppression and prevention



**Figure 29.** European Space Agency Astronaut Leopold Eyharts, Expedition 16 flight engineer, holds a closeout panel in the newly attached Columbus laboratory during the STS-122/ISS-1E (2008) mission. This panel bears the names of European engineers who built Columbus. Note the other white closeout panels—both hard panels and soft fabric panels—inside Columbus.

(Figure 29). These panels, held in place by a few fasteners (that sometimes get stuck and need to be “convinced” to open), serve to close out open spaces and provide a good aesthetic for each module.

## Conclusion

The structures of the ISS provide the critical role of creating a stable platform for the completion of the space station’s mission of scientific research and preparation for exploration beyond Earth orbit. The buildup of the ISS over time and numerous international launches created both unique challenges and unique opportunities that have led to a diverse and highly capable structure. The remaining chapters will explain how crew and ground teams have used the capabilities provided by these structures to ensure the crews remain safe in their orbital home and are able to perform their missions.



Chapter 4 Day in the Life:  
The Making of  
a Mission

**When all goes well, most space missions do not garner any real headlines or discussion in the media.** This absence of coverage understates the amount of effort that goes into making a mission successful. All missions to the International Space Station (ISS) possess common characteristics. This chapter illustrates this process by telling the story of a “typical” ISS assembly mission. During assembly missions, Space Shuttles rendezvoused with the ISS, crews transferred hardware (often a completely new module), astronauts conducted multiple spacewalks (i.e., extravehicular activities [EVAs]), and NASA and its partners established new capabilities. A team of flight controllers, with Boeing engineering support, worked around the clock during each mission to ensure everything went as planned, and to intervene when it didn’t. The orbiter would return to Earth after about 2 weeks, leaving the increment crew behind to carry on while flight directors and controllers working with the ISS Program Office prepared for the next mission.

Planning for such a mission began several years in advance. Initially, the program office detailed high-level objectives that drove the specifics of the mission. Approximately 1 year prior to launch, a group of controllers, led by a flight director whose full-time job was to prepare for the mission, detailed development of the mission timeline, wrote flight rules and procedures, and planned EVAs. A flight director and a team of controllers were each assigned for the two sides of a mission: Space Shuttle and ISS. These represented the prime teams for the mission. In addition, another team was assigned to the ISS increment (see the “Planning” section of this chapter) where the mission was scheduled to take place. The



*The STS-130/ISS-20A crew mission patch. Since the Cupola was a major new module, the perspective represented here is the view of Earth from inside the module.*

three flight directors worked closely together to ensure everything was integrated on both programs.

Change was ever-present in the process of preparing for a mission as priorities and needs shifted such as when a major component on the ISS required repair. In fact, change was probably one of the most significant issues a flight director confronted in preparing for a mission. Needs and objectives changed constantly as a mission evolved: schedules might have slipped; critical hardware could have broken, thus requiring immediate replacement; or a failure on the space station may have driven a late change. Therefore, the teams had to continuously adapt.

Attention to detail, in any plan, is critical. Careful planning and vigilance reduces the chance of surprises or failures. Even so, the flight director and the team spent many a sleepless night during the assembly missions

wondering “What did we not think of? What could possibly go wrong?” Inevitably, things did go wrong. Frequently things went wrong that no one had ever considered. When this happened, the experience, training and preparation of the crew and the flight control team came together to resolve those problems as quickly and as safely as possible.

Training was next. Once the timeline was developed in significant detail, flight control teams and crews simulated the mission’s critical activities. The Space Shuttle flight control team conducted a number of simulations with the shuttle crew, focusing primarily on launch and possible aborts. Likewise, the ISS flight control team assigned to the mission practiced activating the module or other key tasks. However, the increment crew members that would be present during an assembly mission were often scattered around the world, preparing for



their increment or, in some cases, already on board the ISS during these flight-specific simulations. Generic increment crews, often composed of astronauts who had already been crew members on the ISS, played the parts of the actual crews in these simulations. Space Shuttle missions often changed launch dates and sometimes even order (see Introduction). Therefore, multiple increment crews might have needed to prepare for the same shuttle mission, thus making training even more challenging. Both teams conducted several simulations, called “joint sims,” to rehearse integrated tasks such as rendezvous or handing off the module between the robotic arm of the orbiter and the arm of the space station. Once a mission was under way, the ISS increment team ceded responsibility to the prime station team and therefore did not participate in the joint training. The members of the training team were very much part of the team, and they would review the timeline and look for issues to help the flight controllers succeed during the flight.

Execution of the mission followed all the training and preparation. The execution phase—also called “Fly”—included some of the most intense and longest days faced by the flight control teams. Tension built prior to launch since a critical number of operations were about to occur. However, if everyone had done their job, the teams were well prepared to handle any situation. The flight control teams tried to take a couple of days off before launch to rest and close out the last few details.

The 130th shuttle mission/32nd ISS assembly mission—Space Transportation System (STS)-130/ISS-20A—took place over a 13-day timespan in February 2010. The core objective of the mission was to

attach the new Node 3 and Cupola modules. The success of this and many other tasks rested on the shoulders of a highly competent and passionate team that spent years working to make it all happen. Most of the challenges encountered along the way actually occurred on the surface of the Earth. Each challenge was resolved, often in parallel, as the team prepared for the actual mission. With the impending retirement of the Space Shuttle, it was a mission that might never have happened.

## Planning

The assembly sequence of the ISS, as discussed in the Introduction, underwent many changes over the years. Once the plan laid out the order of module assembly, the Space Shuttle Program personnel managed the complicated logistics years in advance to ensure that an orbiter with the right capability (e.g., light enough for a heavy payload) was available for the right mission. More detailed preparation began a few years out from a planned mission. In the case of 20A, NASA assigned the core of the ISS flight control team in the fall of 2007 to a mission that, at the time, was possibly going to be the final shuttle flight. The crew would be assigned about 1 year prior to launch. The STS-130/ISS-20A mission was tasked to accomplish four primary objectives during an estimated 11-day mission, as defined by the Space Shuttle Program and ISS Program. These objectives included:

- Launch the orbiter with Node 3 module and Cupola
- Install Node 3 module on the ISS (but do not activate or connect anything)
- Transfer critical items

- Land the orbiter

During one or more space station increments after the mission, the following would be accomplished:

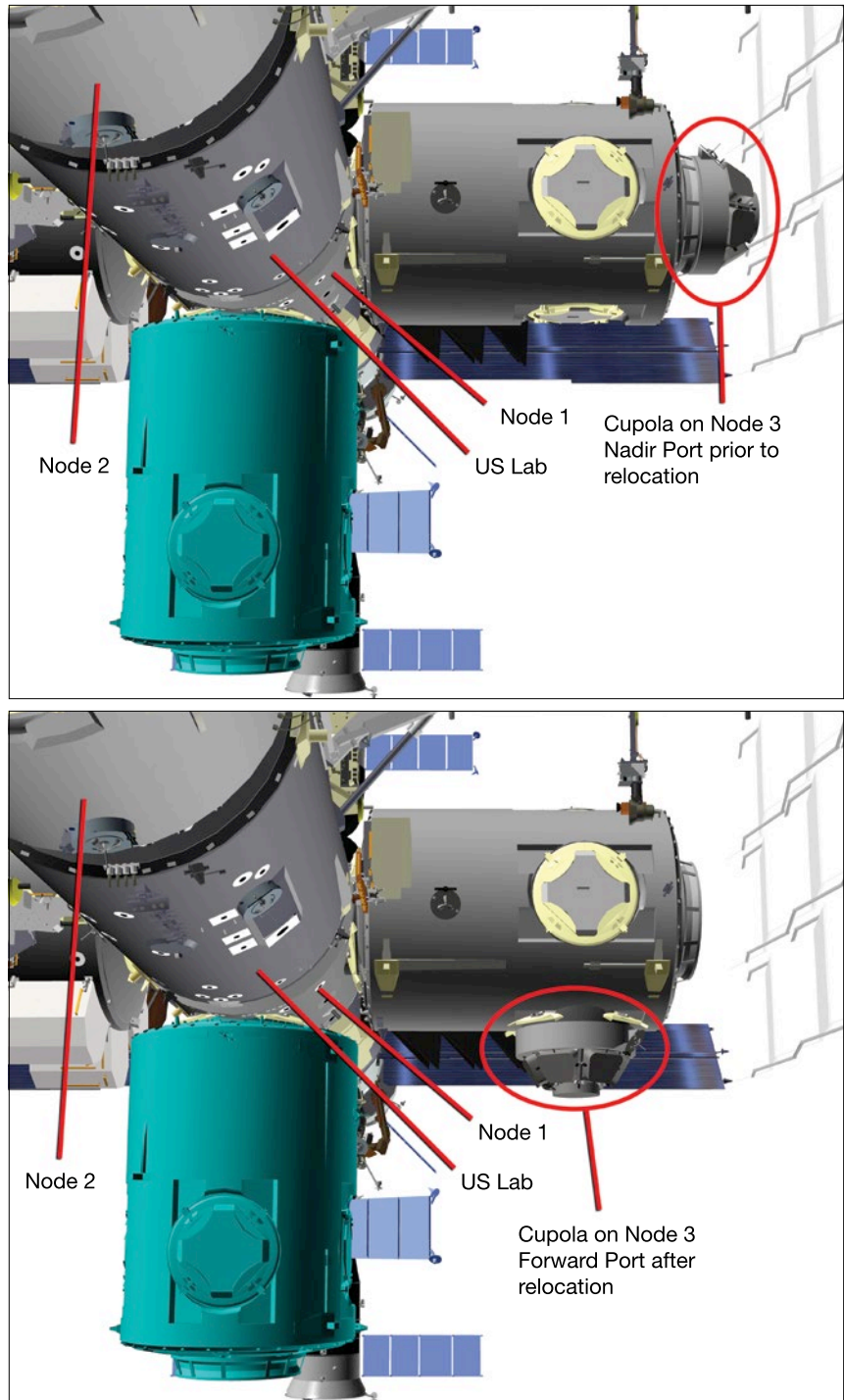
- Attach the power and cooling lines from Node 3 to the main systems of the ISS
- De-mate the Cupola from its launch configuration, at the end of Node 3 module (required for it to fit into the orbiter’s cargo bay, see Figure 2 in Chapter 3), and attach it the nadir side of the module
- Relocate all the regenerative life support systems and exercise equipment to Node 3, which was located throughout the US On-orbit Segment

About 12 to 18 months in advance of an assembly mission, NASA assigned a lead from each Space Shuttle and ISS discipline. The lead’s job was to oversee every aspect of his or her system throughout the process of developing, training for, and executing a mission. This included training the astronauts—both the ISS expedition and the Space Shuttle crews. A designated flight director led and directed each team during the mission development as program requirements and objectives were translated into a timeline, flight rules, procedures, and crew training. Besides being the point of contact for developing the plan, the discipline lead typically worked the primary console shift for the mission. Usually, the lead was a senior flight controller who had supported multiple previous missions as an off-shift controller, a backup to a mission lead, or a backroom controller (see Introduction) before being assigned a mission of his or her own. Some flight controllers had the privilege of working multiple missions as a lead over the course of their careers. Typically 6 to 12 months in advance

of a mission, the teams of a flight controller and a flight director would be assigned for the other two shifts (missions always worked with three 9-hour shifts around the clock).

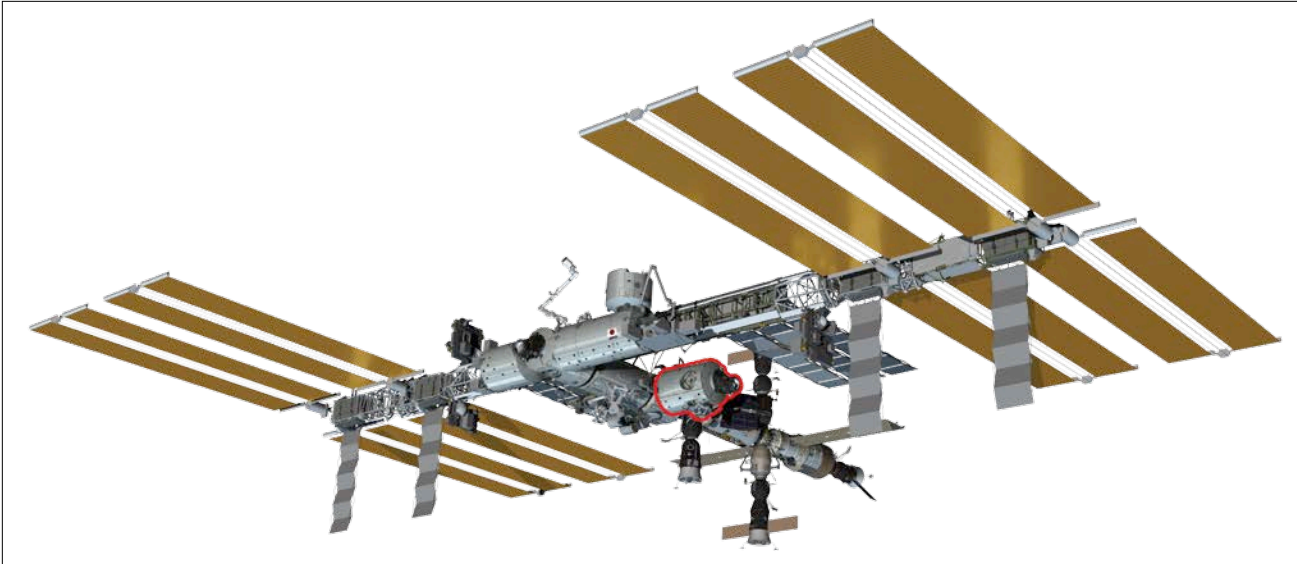
Several flight controllers had to be assigned more than 2 years prior to the STS-130/ISS-20A mission. These assignments included the leads for EVA, Operations Support Officer (OSO), and the Environmental Control and Life Support System (ECLSS). The lead EVA officer is usually one of the first to be assigned to a mission because spacewalks take a long time to plan, train for, and execute. However, the lead OSO would also be busy on this flight because the STS-130/ISS-20A mission involved a lot of hardware changes and the berthing of a module. In fact, because the OSO task was so large, several people were assigned at an early stage, including one whose main job was to focus on the Node 3 module whereas a separate person focused on the Cupola. Major changes to the ECLSS, including additional components in the regenerative environmental control system, were scheduled to occur during and after 20A.

Normally, mission preparation ramped up slowly as the plan was developed, first taking the major objectives listed above and creating a timeline as tasks were added. Preparation for 20A got off to a busy start as the ISS Program officials considered changing the location of Node 3 on the ISS. Originally, the module was to hang down in the nadir direction, pointing toward the Earth with the Cupola facing forward (the direction the ISS flies around the Earth), as shown in Figure 1. In this configuration, NASA's crewed vehicle, Orion, and the Japan Aerospace Exploration Agency's uncrewed cargo ship, H-II Transfer Vehicle (HTV), were to



**Figure 1.** Initially, the Node module was supposed to project nadir (teal blue silhouette); however, it was changed to the port side. The Cupola would be launched on the end of Node 3 to fit in the cargo bay of the orbiter, and then relocated to its permanent position through use of the robotic arm. Inset: launch configuration of the module pair with Cupola on the end of Node 3.

Images courtesy of MAGIK Robotic Analysis Team



**Figure 2.** Drawing of the ISS now showing Node 3 berthed on the port side (red outline).

be attached to the space station at the nadir side of Node 3. But it was realized that interference could occur with the Russian Mini-Research Module projecting nadir from the Functional Cargo Block module. The nadir of the Mini-Research Module was also to be the location for the Soyuz and, possibly, Progress vehicles. Although visiting vehicles such as HTV, Orion, and Soyuz could likely dock and undock with no interference, the ISS Program officials decided to ensure a certain amount of clearance due to unexpected errors, uncertainties in sensors, or systems failures. A miscalculation could cause a collision (similar to when a Progress vehicle struck the Russian Mir station in 1997 with US astronaut Michael Foale on board), destroying a module, or worse, the entire station.

To solve the clearance issue, ISS Program officials asked whether Node 3 module could be installed on the port (left) direction off of Node 1, as shown in Figure 1. Although the berthing mechanisms were designed to allow a module to be mounted in any orientation, the plumbing to that

module was not as accommodating. All of the ventilation lines, computer circuits, water tubes, nitrogen lines, and communication cables had been installed years earlier in Node 1 under the assumption that Node 3 would be on the nadir. To place Node 3 on the port side meant all these had to be rerouted—in space. Furthermore, the electrical power cables and the external ammonia lines used for cooling the Node electronics would have to be rerouted. Figures 1 and 2 show the final proposed configuration.

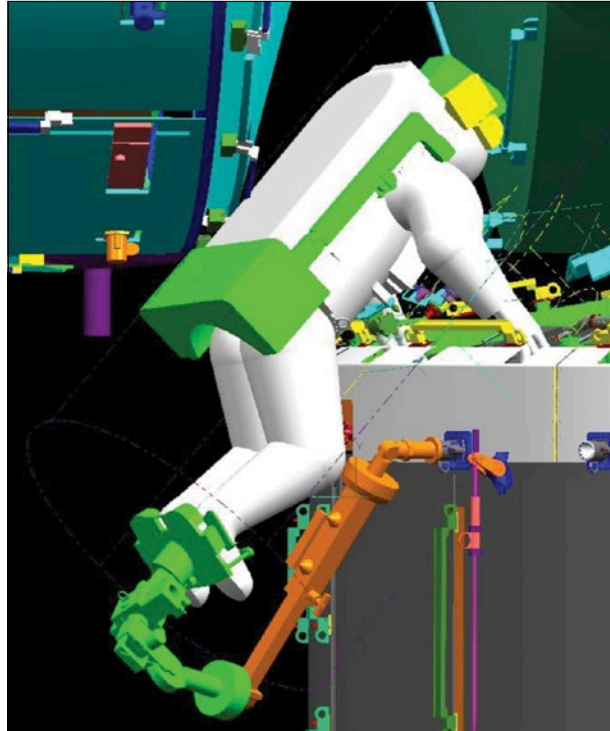
As was typical of the flight control and engineering teams, the question was not whether they could do this, but how they could make it work. The first task was to figure out how to modify the Node 1 module that was already on orbit to accommodate the change and make sure the hardware and procedures could be done by the ISS crew. The task was analogous to modifying a bedroom by moving the bathroom to the other side of the room. The changes also would have to be somehow verified in advance to ensure that everything aligned just right when Node 3 was installed

during the mission. Node 1 was already in orbit, so no direct fit checks could be performed. The teams had to use the Node 1 mock-up in the training facility. The mission would be a complete disaster if the shuttle was launched and then Node 3 could not be physically mated to Node 1. Even if the modifications to Node 1 could be made, they had to be done in the limited time available to the astronauts with the training that could be accommodated in the already-packed training schedules. If the modifications were not completed before NASA retired the Space Shuttle fleet, Node 3 module might never make it to orbit.

The first of many issues arose as this was being worked out. Although the berthing mechanism could, in principle, accommodate a module in any one of four orientations 90 degrees apart, bumpers existed on both modules to provide additional protection when two modules were mated. The result was that Node 3 could only be installed in two of four orientations on Node 1. Either option had the module lights on the back

wall (i.e., away from the direction of motion) or the forward wall (i.e., toward the direction of motion) from a crew perspective. This seemingly minor issue was an important one for the crew. No “up” or “down” exists in space; therefore, any reference frame is artificially introduced. The lights on all of the other modules were in the same orientation (on the “ceiling”) to provide an “up.” If this one module was different, it could be disorienting for the crew, especially during an emergency where visibility was greatly reduced due to smoke. If the node was rotated 90 degrees, the lights would again be on the “ceiling.” To do this, the bumpers from Node 3 would have to be removed and the plumbing would have to be rerouted a little differently on Node 1. Removing the bumpers was relatively easy with Node 3 still on the ground. Since the plan was to gut Node 1, it really didn’t matter where the lines were routed; therefore, changing the destination by a few more feet was not an issue. The biggest roadblock was actually external.

Two boxes—InterFace Heat eXchangers (see Chapter 11)—are located on the outside of Node 3 where the cool ammonia on the outside removes heat from the internal water lines. In the new orientation for Node 3, an astronaut would not be able to replace these units due to interference from the Laboratory module (Figure 3). Although the likelihood of a failure was estimated to be one failure in 29 years of continuous operation, the impact was significant: if either one of these heat exchangers actually failed, half the systems in Node 3 would have to be shut down permanently. In 2007, the hope was that the ISS would be flying until at least 2028; therefore, the risk was real enough to spend some time considering the overall situation.



**Figure 3.** A computer-aided design drawing showing an astronaut working on Node 3 heat exchanger with the Laboratory module over the left shoulder. Note that there are just a few centimeters (inches) of clearance between the astronaut’s life support backpack and the Laboratory module. It would be nearly impossible to work in such a small area without banging into the module and possibly damaging the spacesuit.

With support from the engineering community, the flight control team began to work out a plausible repair scenario. If a heat exchanger needed to be repaired, the team could unberth Node 3 using the robotic arm, rotate it 90 degrees, rebirth it temporarily, perform the repair, and return it to its normal configuration. This also meant the crew would have to disconnect the external ammonia cooling and electrical power lines before the operation started, and reconnect them when done. At least two EVAs would be added to any repair operation, in addition to potentially exposing the crew to toxic ammonia. This whole process would not be a trivial operation since everything in Node 3 would have to be shut down for days, if not weeks, while the crew conducted multiple spacewalks and never-before-performed robotics operations. Since Node 3 would house many of the vital life support systems, shutting it down for any length of

time would impact the mission. The solution was to lengthen the electrical lines significantly so that they would not have to be disconnected (the ammonia lines already had enough slack in them to remain connected). This complicated pas de deux took several months to work out with confidence, and included several test dives in the Neutral Buoyancy Laboratory (NBL). Once the team was comfortable that this repair could be performed, if ever needed, it was agreed to reorient the module to make it seem more natural for the crew.

Making the modifications to Node 1 would require extensive work. The OSO team estimated that at least 120 man-hours would be needed to modify Node 1 on orbit. To add to the difficulty, some tasks could not be performed prior to the installation of Node 3. For example, water and oxygen lines run between the modules (see Chapter 3). If Node 3 was ever struck by debris and depressed, the

crew needed to be able to close the hatch to preserve crew members and the rest of the ISS. Therefore, these oxygen and water lines could not run through the hatchways. The lines are actually located within the aluminum structure of Nodes 1 and 3, passing through what is called the bulkhead. The required modifications to Node 3 were made prior to launch. However, for Node 1, this meant the crew had to make new holes in the port side, reroute the lines, reseal the bulkhead, and carefully check for leaks to ensure the integrity of the new seals. To perform the leak checks, the crew first needed to make the modifications and then measure for leakage on both sides of the seal. This was not possible without Node 3 in place. At that time, the other side of the wall of Node 1 was a vacuum. Per the initial mission plan, Node 3 would be installed and the crew would perform the modifications after the shuttle left. This meant, however, that the many hours needed to activate and outfit the module would have to be performed by three people—without the benefit of the seven extra astronauts that were available during a shuttle mission.

The flight control team came up with an interesting proposal. A small connector module called the Pressurized Mating Adapter (PMA)3 resided on the ISS. Atlantis docked with PMA3 during the STS-98/ISS-5A mission, but the module was not currently being used. This module could be moved by the robotic arm and installed on Node 1, thus providing a pressurized area in which to make the changes. The module would be moved back to its original location upon completion of the modifications. If the 120 hours of crew time could be found during the increment for this task, the modifications to Node 1 could be performed prior to the ISS-20A

mission. This meant Node 3 could be connected and activated during the flight (i.e., “plug-and-play,” as the team called it) when those extra sets of hands are available. As with the change in the port location of Node 3, this had to be carefully coordinated and reviewed, especially since it meant taking the expedition crew away from research during the increment. However, a little investment in the time of the increment would significantly increase the larger shuttle crew’s efficiency. The more tasks completed during the shuttle mission, the less work for subsequent increments. This resulted in a net gain of increment time in which to focus on research. Many reviews and meetings later, the idea was given approval by the ISS Program.

Originally, the modification hardware was to go up on 20A because it would be installed after the flight. With the new plan, the design, fabrication, and testing had to be accelerated to go up on an earlier shuttle flight. This proved to be a real challenge to the Boeing team members, but they worked extremely hard to pull this off.

Another challenge discovered at this point was that the planned route of the power cables would be blocked as soon as Node 3 was installed. Therefore, the power cables had to be installed prior to the 20A mission. The STS-128/ISS-17A team members picked up this task because they had some spare EVA time.

In 2008, the timeline leading to 20A changed to the following series of events:

- During the interval following the second Japanese/American mission, STS-127/2 J/A, the ISS crew would move PMA3 from Node 1 nadir to Node 1 port using the station’s robotic arm

- On STS-128/ISS-17A, the crew would route the power cables from nadir to port during an EVA
- After STS-128/ISS-17A, some Node 1 modification work would begin if the parts could be accelerated to be ready in time
- STS-129/ISS-Utilization Logistics Flight (ULF)-3 would bring up the remainder of the Node 1 hardware and finish most of the modifications
- After ULF-3, the PMA3 would be relocated back to its pre-2 J/A location on the nadir of Node 1 by the ISS crew, again using the station’s robotic arm.

20A crew would install Node 3  
The 11-day mission now looked like this:

- Launch the orbiter with Node 3 and Cupola
- Install Node 3 on the ISS
- Install ammonia lines, activate the module, and integrate the ammonia cooling into the system
- Transfer critical items
- Land the orbiter

Finally, the following would be completed after the mission:

- Relocate the Cupola from the end cap of Node 3 to its permanent nadir location
- Relocate the life support systems into Node 3 and activate
- Move the Advanced Resistive Exercise Device into Node 3
- Move the Treadmill 2 (T2) into Node 3

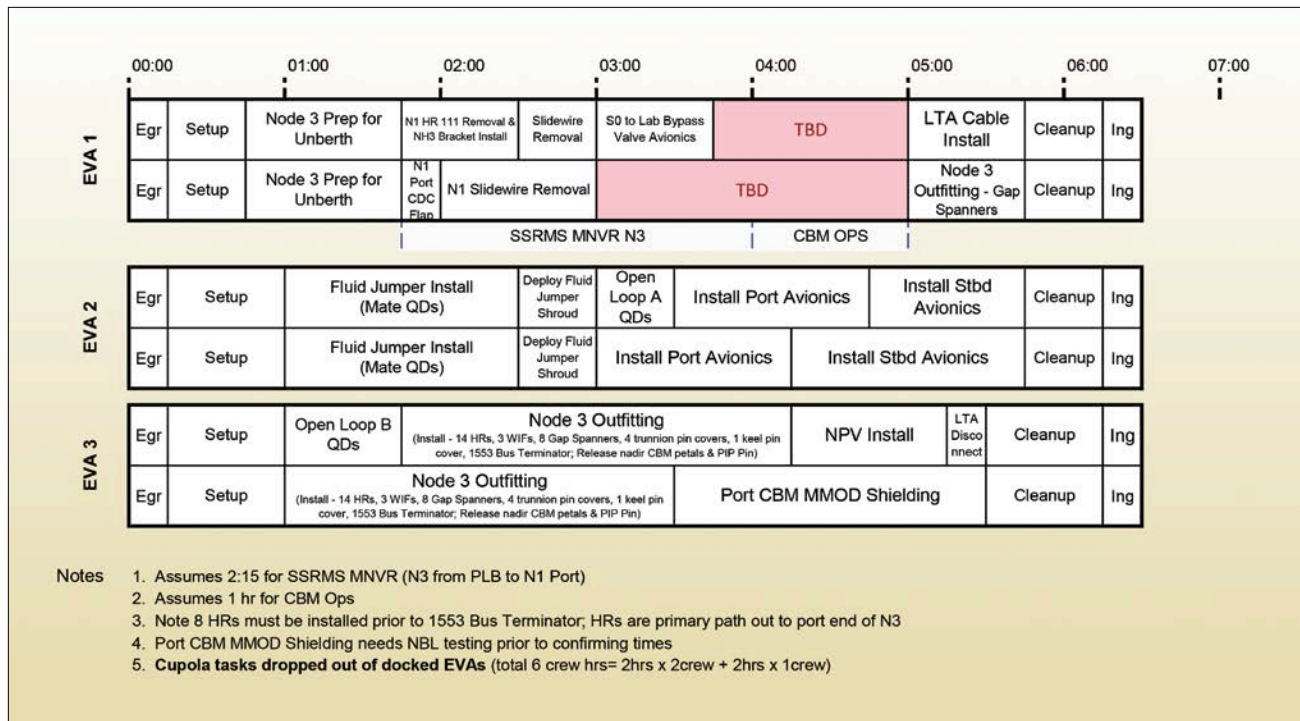
## Spacewalks

The spacewalk plan for the mission, as dictated by the key mission objectives, was evolving as well. To help preserve the limited oxygen on the ISS, it was preferable to perform spacewalks during Space Shuttle missions so that the tanks could be topped off before the orbiter undocked. Therefore, the ISS Program officials preferred to schedule as many spacewalks as practical during a docked mission. Over the life of the ISS assembly, the number of spacewalks grew from one, to two, and sometimes three during shuttle missions. By the fall of 2008, three spacewalks were standard, as shown in Figure 4. Tasks similar to those performed during previous missions were well known

and their time estimates were pretty accurate. For new tasks, however, the performance estimate was usually pretty conservative until dives in the NBL could provide a better indication of the required time.

The first EVA accomplished removing Node 3 from the orbiter cargo bay and berthing it on the ISS. The first thing the crew did was disconnect the Launch-To-Activation (LTA) jumpers. The LTA jumpers provided power to the heaters in the module, thereby keeping the hardware from freezing until the Thermal Control System was fully functional. The protective flap covering the hatch window (see Chapter 3) needed to be opened to allow the crew that was using the Centerline Berthing Camera

System to see the incoming Node 3. The shuttle crew used the SSRMS to grapple Node 3 (see Chapter 15) and move it into the berthing position. Although a number of small tasks needed to be done on the outside of Node 3 (e.g., installing hand holds used for future spacewalks), this could not be done while the SSRMS was moving the node. Therefore, the team needed to find other tasks to fill this large gap in the timeline. Once the module was berthed, the astronauts reconnected the critical LTA cables. These tasks consumed all of the time available for the first EVA. In fact, it took so long to move and bolt the module that the team ran the risk of running out of time before completing that task.



**Figure 4.** STS-130/ISS-20A EVA timeline from October 2008. Note that there is still open time on the first spacewalk since the crew could not touch Node 3 while the Space Station Robotics Manipulator System (SSRMS) was maneuvering Node 3 into position prior to mating to Node 1. The Launch-to-Activation (LTA) cable, which is used to keep the module from freezing, is disconnected during the installation and reinstalled at the end of the first spacewalk until the internal systems can be activated on a later mission day. The loop A and B Quick Disconnects (QDs) indicate where the ammonia lines are integrated into each of the cooling systems. One astronaut would be on the end of the SSRMS during the removal of the Multilayer Insulation (MLI) that protected the Cupola until it was activated, as well as the removal of the locks that held the protective windows in place during ascent. Note that the timeline mentions jettisoning the MLI, but this was later deleted in case the insulation was needed in the future (i.e., in case the Cupola had to be relocated).

The second spacewalk primarily focused on installing the ammonia jumpers along with the main power and data connections that had been previously installed on the outside of the ISS and routed. The ammonia lines had to be installed first for two reasons: it was the main objective of the spacewalk for that day; and ammonia could leak out when integrating the ammonia hoses with those already in use on the ISS. Ammonia is highly toxic and can be tricky to see. Just a little on one of the suits could kill the entire crew once the crew members got back inside. The EVA team developed complicated procedures to detect ammonia and clean the crew before opening the hatch. Among other things, the affected crew member had to sublime the crystals off the suit using a warm metal tool. Then, he or she would float to a sunny spot in space and hang out for a while to allow any possible remaining ice crystals to evaporate. Once in the airlock after repressurization to 259 mm Hg (5 psi), the crew member measured the amount of ammonia in the air before fully repressing and removing his or her helmet. If ammonia was detected, the contaminated atmosphere would be vented overboard and fresh air would be pumped in. Again, the check was performed and repeated until it was safe for the crew. Since the spacesuits only had a limited amount of consumables (e.g., battery power, oxygen), time for these cleanup procedures (~90 minutes) had to be planned for in the timeline.

At that point, only one more spacewalk was planned. The intent was to prepare the Cupola for its later relocation from its launch position to its permanent nadir location (see Figure 1). This meant removing the

insulation and locking bolts on the external shutters that were required to prevent launch vibrations from causing damage. Since the insulation was large and bulky, the team decided to jettison it (i.e., throw it away in space so it would reenter Earth's atmosphere and burn) rather than return it to Earth inside the shuttle. Since there was a chance that the Cupola might need to be moved again in the future, the team later changed this decision and the insulation was taken inside and stored on the ISS.

As team members better understood the time required to perform each activity, they saw several opportunities to get ahead. In particular, they concluded that there might be time to perform the Cupola relocation. This task would benefit from the extra available shuttle astronauts, and its completion during the shuttle mission would reduce the crew's workload in the smaller increment. Therefore, in the spring of 2009, the team added the Cupola relocation to the end of the second EVA. This also meant a quick activation of the module because electronics were needed to operate the berthing mechanisms and cooling was needed to prevent the electronics from overheating. Choreography would be tight.

Integrating Node 3 cooling lines into the existing ISS systems meant shutting down those systems. As discussed in Chapter 11, the external cooling system is broken into two functionally redundant, separate loops—A and B. Choreography would then look something similar to this:

- Power down systems on loop A
- Turn off loop A cooling
- Astronauts to disconnect the hoses and integrate Node 3 lines on the A side

- Turn on loop A cooling
- Power up systems on loop A
- Verify everything is working properly
- Repeat for loop B

This took a fair amount of time. Spacewalking astronauts had approximately 6.5 hours to conduct the EVA (see Chapter 17). Therefore, only one set of lines would be opened on this EVA. Next, the ground activated the key systems of Node 3. Once the module was basically working, the attachment mechanisms could be used to relocate the Cupola. Although this sounds straightforward, any glitch would derail the entire plan. The flight control team and training team began extensive work to refine the activation procedures and to train them very carefully.

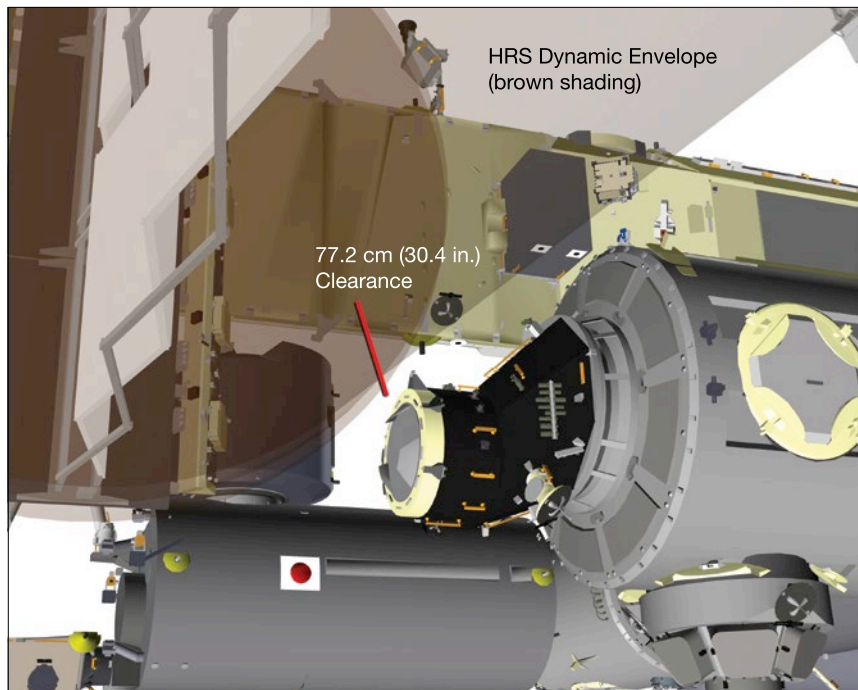
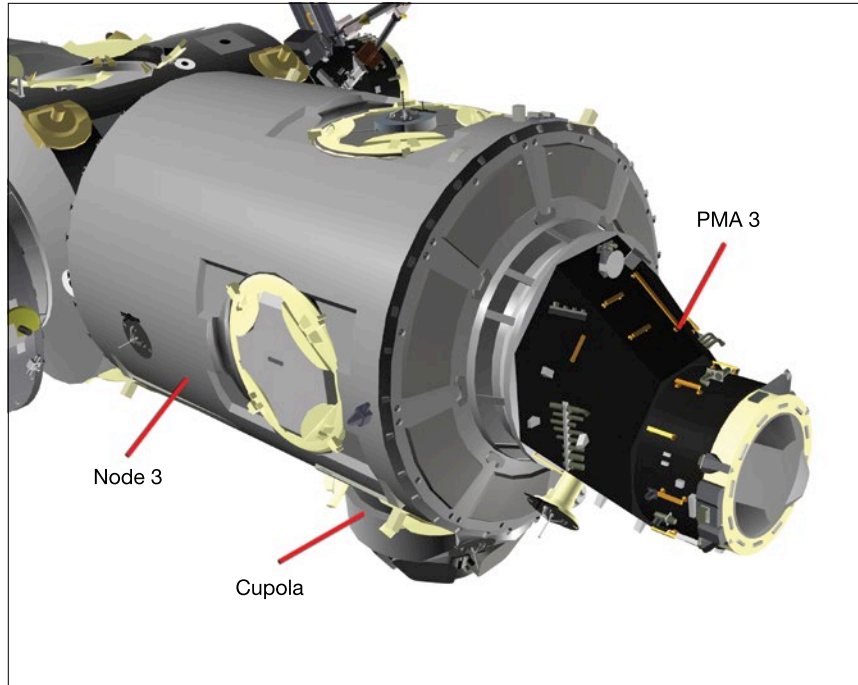
### *Remodeling*

With the current EVA timelines, some free time was still available during the mission. The ISS Program officials asked whether the team could move the PMA3 module from its current temporary position to its new home on the end of Node 3—i.e., the port end (Figure 5)—where the Cupola was located at the time of launch. After the robotics, EVA, and OSO teams assessed the proposal, a workable plan was developed; however, the plan required adding another day to complete the mission.

Adding days to a shuttle mission required substantial analysis to ensure the supplies required for the seven-member crew could fit on the already busy and heavy mission. With the Space Shuttle Program winding down, the ISS Program was looking to take up as much equipment and supplies as possible.

Therefore, a trade occurred among supplies and hardware for the ISS, supplies for the shuttle crew for an extra day, and the amount of work those additional astronauts could perform in the allotted time. An additional factor was that as the mission got longer, the team had to allow the crew a day off to rest.

Also around this time, the ECLSS team realized that with the many available hands of the shuttle and increment astronauts, significant progress could be made in relocating the regenerative life support and exercise racks that were destined to be installed. This promised to be a complicated task. Much of the US Segment life support system would have to be shut down, transferred, installed, and reactivated. This large amount of work had to be accomplished in as short a window as possible because of the critical need for life support and the additional demand of seven more people on the station at the time. Since the team had to add a day to the mission to relocate the PMA3, this provided an extra day to start the rack relocations (i.e., two crew would perform the PMA3 robotics operations while the remaining crews could work on configuring Node 3). It was assumed that the programs would find this worth the cost of adding supplies to the mission. By the end of the summer of 2009, the mission had grown to a 13-day mission. However, to be conservative and to allow for things going wrong, the additional day was considered optional and would be officially added to the timeline only during the flight if all was proceeding reasonably according to plan. If things did not work out well, these tasks would fall to future increments after the orbiter departed.



**Figure 5.** The PMA3 relocated on the port end of Node 3 (top), showing the tight clearance with the radiator (bottom) where the brown shading illustrates the dynamic clearance envelope of the moving radiator.

Images courtesy of MAGIK Robotic Analysis Team



Node 3 was closed off for a couple of days, and was therefore unavailable for the astronauts to begin any outfitting. If the crew could work in Node 3 and prepare the Cupola for relocation, this task could be done during the docked shuttle mission. Four key issues had to be overcome for this to occur. First, although the modules were constructed in clean rooms, there were always small bits of debris that could not be found and removed on Earth. Once in space, these particles float freely, posing an eye injury or inhalation risk. Therefore, for the new modules, the safety engineers required the fans be up and running for some time before the crew could ingress. In this way, the filters would have time to capture all the loose debris. The second concern was that carbon dioxide and humidity would build up inside Node 3 if no airflow was present in the module; furthermore, the buildup of humidity would result in condensation. Next, the module would be dark inside since the power would not be available for lights. A final issue was the inability to determine whether ammonia was somehow leaking into the cabin. Normally, the pumps and computers have sensors to detect the presence of ammonia.

The ECLSS and Thermal Operations and Resources teams, with support from the BioMedical Engineer group and Boeing engineers, came up with workable solutions. The astronauts would wear eye goggles and surgical masks to prevent the debris from causing any injury, even though these options weren't particularly comfortable.

To solve the second issue, the ECLSS team combined gray tape with some unused ducting that was tucked away with another duct (one that

was normally used to help pump air into the orbiter). This effort created a 7-m (23-ft) long duct that would be relocated into the Cupola during the time the astronauts were inside. If the crew members were in Node 3, they were not going to be on the orbiter. Therefore, the duct was connected to an IntraModule Ventilation fan in Node 1 and dragged into the inactive Cupola vent. Note that any cables or hoses passing through a hatchway were normally not allowed because if a catastrophic cabin leak were to occur, the crew would have to be able to exit the module and quickly close the hatch. The ECLSS team worked out a plan with the astronauts so that this could be done quickly during the small window of time in which the astronauts were inside Node 3.

Portable lights ensured visibility. Finally, the team analyzed and concluded that if the ammonia was not flowing through any of the cooling lines, the risk of a leak was acceptably low enough to allow the crew to be inside the module. This mission was evolving into one of the most challenging for the ECLSS team, as it had for the OSO team.

With approval from both programs, work to add these tasks to the mission began in earnest. As with any task, the PMA3 relocation grew more complicated as the team worked out additional details. With the PMA3 on the end (i.e., port side) of Node 3, the clearance between the farther port radiator panel and the module was going to be tight (Figure 5, bottom). In fact, at this point, the team didn't even know whether there was enough clearance. When thousands of parts have been built by many different people from around the world, pinpointing the measurement of the final assembled structure was not an

easy task. The size of all parts were recorded in drawings and in computer models, but verification was required to ensure everything was actually built as planned. Thermal expansion and, more critically, the flexing of the radiator panel as it moved also had to be taken into account. After careful calculation, engineers estimated that there was slightly more than 2 feet of clearance. Yet, that was true only if the calculations were right. In the event of a calculation error, the radiator and PMA3 could endure serious damage.

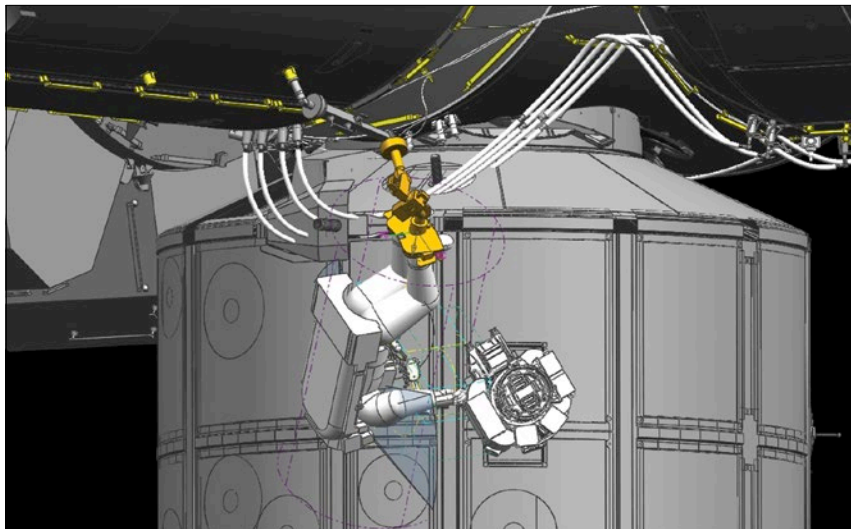
The station team developed a conservative plan in case of calculation errors. After Node 3 was installed on the ISS with the Cupola still positioned for launch, the robotic cameras took images that were used to measure the exact clearance. Although the PMA3 was different than the Cupola, this was much closer to reality and permitted the engineering team to get more precise measurements. Images were taken from multiple positions to generate photogrammetry for a three-dimensional (3-D) model. After Node 3 was installed early in the mission, and before the team was given the green light to move the PMA3, engineers analyzed the 3-D model to ensure their preflight calculations were right. The team also had to develop a flight rule that stated under what conditions it would be "go" for the relocation.

The team remained cautious. The plan was to move the PMA3 between the second and third EVA. This meant the Cupola had to be moved quickly after Node 3 was up and running to open up that berthing port for the crew to hook up the heater cables on PMA3 during the third spacewalk. Even so, the team planned to methodically move the

radiator toward its final position on the PMA3 and watch with the cameras to confirm the clearance. After plenty of margin was confirmed, the radiator was allowed to rotate freely and be “go” for the relocation.

A new problem surfaced in the fall of 2009. With the decision to install the new Permanent Multipurpose Module (PMM) on the nadir side of Node 1, concern arose that the billowy insulation over the ammonia lines that ran right beside the Node 1 nadir berthing port might interfere with the module during installation. Analysis showed that the lines would pass *through* the PMM (Figure 6). This is what happens when late changes are made to a program that has been working on these issues for years. The team had to adapt.

Once the issue was identified, the team came up with some modifications to the insulation and tie-down plan (Figure 7). Newly mocked-up ammonia lines were built and the crew practiced the EVA in the water at the NBL. The EVA team became concerned that the modifications were not adequate enough to ensure clearance with the PMA3. With approximately 4 months remaining before flight, it was getting late to work out some of these issues. The team convinced the ISS Program officials that it was prudent to temporarily shuffle the PMA3 to the top of the Node 2 zenith to ensure it was not in the way. This meant a lot of new, last-minute work, but this removed all the residual risk. Training for the task of moving the PMA3 also had to be quickly performed and scheduled during Expedition 22—less than a month before the mission. Fortunately, the ground and crews were becoming highly experienced at moving PMA3.



**Figure 6.** A computer-generated analysis showed the ammonia hoses (four white lines) for Node 3 (upper left) would pass through the PMM near the astronaut's feet on their way to Node 1 (upper right).



**Figure 7.** The spacewalking astronauts from STS-130/ISS-20A and EVA team try to figure out a new routing of the ammonia lines and the insulation using a crude mock-up of where the connectors would be on the various modules.

The other half of the ammonia lines would be integrated on the third EVA. Within this time frame, Boeing engineers worked out a new plan for the ammonia lines so they would not interfere with the PMM. Elbows with

90-degree turn would be added to the lines to angle them away from the PMM. Tethers would then be used to tie the lines back. This required a great deal of analysis because the tethers had to be installed prior to the

lines being pressurized (they might be too stiff to move after), but they had to be strong enough not to break when the hoses were pressurized.

At this point, the mission had changed a great deal. The plan now included the following:

- Launch the orbiter with Node 3 and Cupola
- Install Node 3 on the ISS during the first spacewalk
- Outfit the vestibule of Node 3 in preparation for activation and ingress
- During the second spacewalk, install two pair of the ammonia lines and open one pair to begin cooling and

allowing for activating half of the module. As soon as the systems were working, relocate the Cupola from the port end of Node 3 to its nadir side. Perform 3-D imagery analysis to verify radiator clearance.

- The next day, move the PMA3 from its temporary location on top (zenith) of Node 2 to the port end of Node 3
- During the third spacewalk, integrate the second ammonia loop, open the shutters on the Cupola, and take photogrammetry to verify the PMA3 will not interfere with the Thermal Radiator Rotary Joint and that the PMM will not interfere with the ammonia lines

- Transfer critical items including life support systems
- Land the orbiter

### ***The Challenge of the Ammonia Lines***

The ammonia lines (see Chapter 11) actually turned out to be another major challenge for this flight. The four lines needed to be about 8 m (~25 ft) long—the longest lines on the ISS. In addition, the ammonia could be at a fairly high pressure (3,400 kPa or 500 psi—more than 10 times the pressure in a typical car tire) to ensure enough fluid was passing fast enough to provide an adequate amount of heat-removal capability. Once in place and pressurized, a rigid line

## **What's in a name?**

In 2009, NASA initiated a novel public outreach project: have the public name Node 3. Each module of the ISS, however, had been given a friendly name by its country of origin (see Introduction); therefore, NASA set up a website and asked the public to submit names for Node 3. The most popular name would be selected. Comedian Stephen Colbert of the Comedy Central show *The Colbert Report* tried to get his audience to name Node 3 after him. This campaign proved hugely successful and his entry (the “Colbert module”) was at the top. By law, NASA could not name a module after a private citizen or commercial entity, which put the agency in a difficult situation. Colbert did a great job of raising awareness of the mission. To show appreciation for his efforts, NASA sidestepped the issue directly by naming the module *Tranquility* and coming up with a consolation prize: naming the new treadmill in Node 3 after Colbert. Initially called by the accurate-but-unexciting name of T2, the treadmill was rechristened the Combined Operational Load Bearing External Resistance Treadmill, or COLBERT (Figure 8). It even had an official logo.

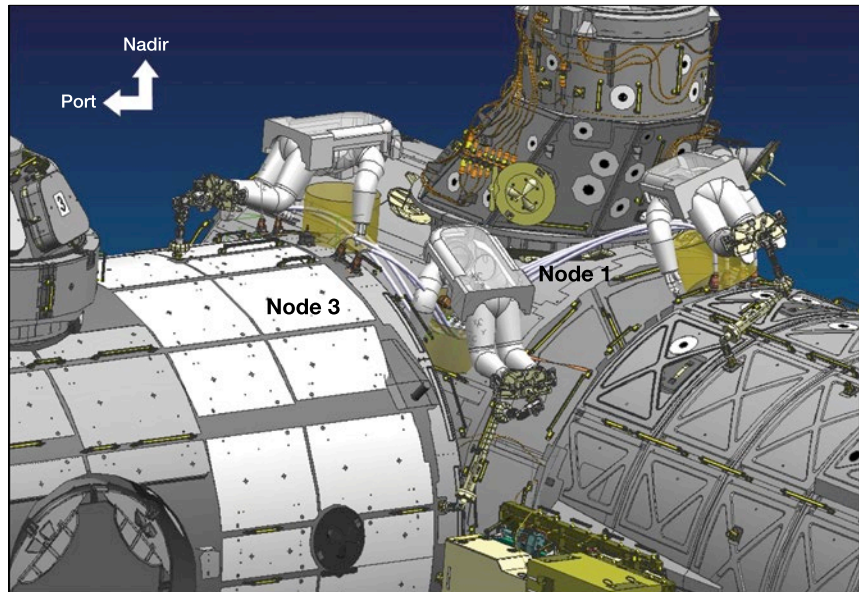


**Figure 8.** Tom Marshburn of Expedition 34 exercising on the COLBERT in 2012.

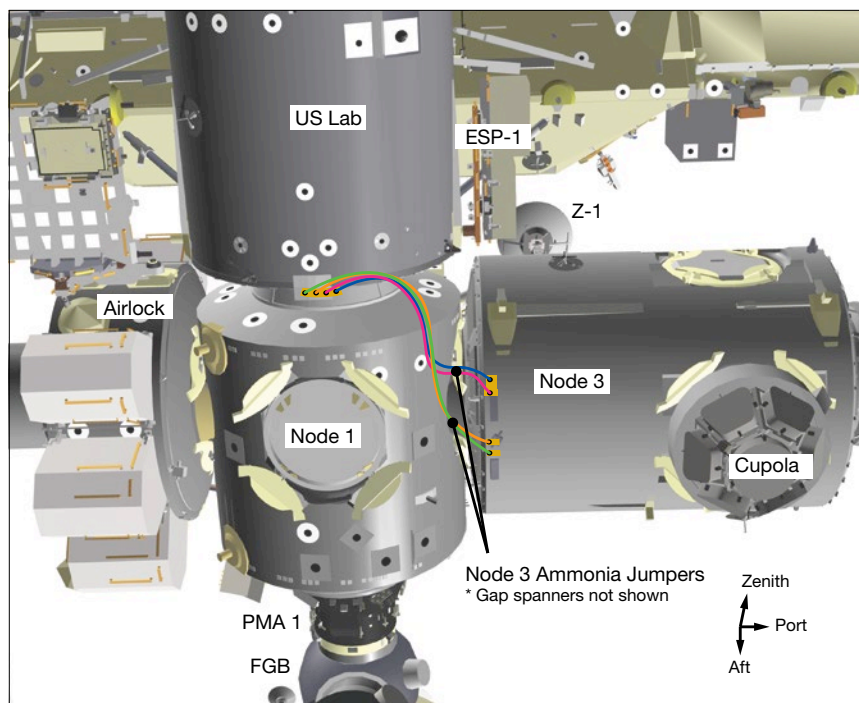
was not an issue; however, the crew members needed to be able to route and install the lines while wearing their bulky space suits. Therefore, NASA chose a flexible design. A line of flexible hose was to be attached to longer hoses using a braided sleeve welded to the joint. This is shown in Figures 9 and 10. The hoses were scheduled to be completed in May 2009 (9 months prior to flight).

A significant setback occurred in July 2009 (about 7 months prior to flight) when an ammonia hose exploded at 50,300 mm Hg (973 psi) during pressure testing on the ground, causing significant damage to a second line nearby. Normally, the lines operated at approximately 20,000 mm Hg (380 psi) with a program requirement to be able to withstand pressures of 52,000 mm Hg (1000 psi). A safety valve should open at 23,300 mm Hg (450 psi) completely venting the lines in the event of a problem, such as a pump running at too high of a speed. The hoses were tested up to 52,000 mm Hg (1000 psi) to ensure that the lines would not rupture if the valve itself failed. Analysis of the exploded hose seemed to indicate that the explosion was the result of a manufacturing issue and not a design problem, thus new lines were produced. The number of braids in the welding was doubled to improve margin.

The new hoses began testing in November 2009. One of the hoses showed a leak. Metallurgical analysis revealed that liquid-metal-induced embrittlement during the welding process led to the failure. At this point, the team was less than 3 months to launch. To add insult to injury, a third hose that had passed testing was damaged during shipping



**Figure 9.** Graphic showing where the four ammonia lines would be routed from the S0 truss to Node 3. (Note that this figure is meant to show crew access for a given astronaut. Only two astronauts would actually perform the spacewalk.)

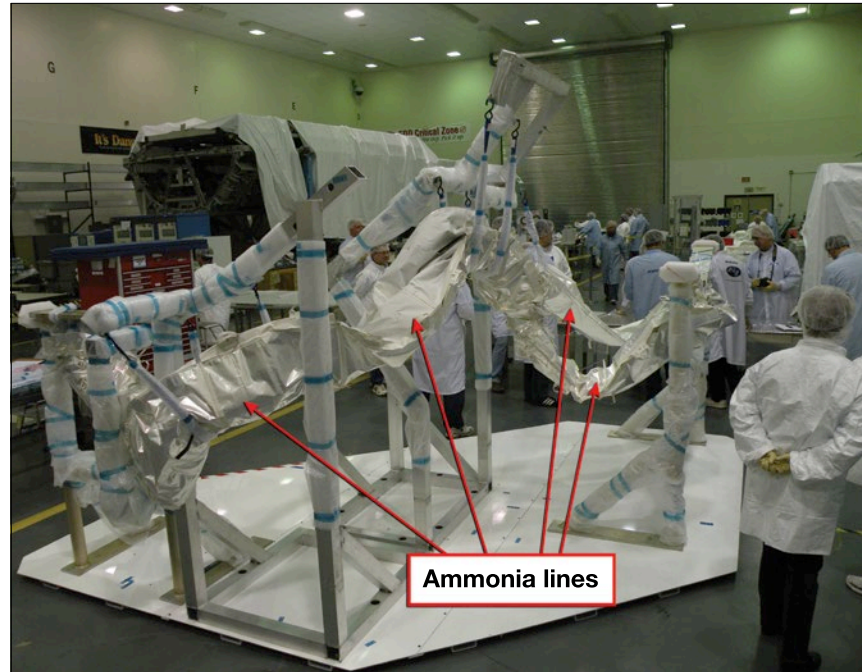


**Figure 10.** A schematic showing the routing of the ammonia lines (colored). There are four ammonia lines—one for the ammonia flowing to and one for the ammonia flowing away from the pump for each the A side and B side.

Images courtesy of MAGIK Robotic Analysis Team

from the manufacturer. Of great concern was that the damage seemed greater than one might expect from simply dropping the container. This led some to think a critical design flaw would prevent the lines from meeting their stringent requirements.

At this point, a “tiger team” was formed. A tiger team is a panel of experts given the authority to focus on a particular issue until a resolution is found. At an already busy time, numerous reviews and meetings were occurring at all hours of the day and night, all over the country. When the great sleeping beast that is NASA awoke, all resources turned to this problem. Many members of the 20A flight control and engineering teams were busy supporting the tiger team. In addition to understanding the issues, the team had to identify impacts that any proposed solution would present to the mission, and then figure out how to modify procedures or training. All of this had to be done while continuing the other ongoing work and training. On any mission, the teams sprinted to the finish line to have everything in place. The extra work provided additional pressures and the lead flight director had to ensure that members of the operations team did not burn themselves out before the mission. Several parallel paths were chosen. First, more of the original hoses were being produced. With the revelation that the embrittlement was caused by welding, a new welding process was adopted to hopefully prevent this from happening. In addition, hoses using a new design were being built. Instead of the flexible line and sleeve, the middle would be a solid tube and a basic metal-to-metal, or butt-weld type



**Figure 11.** Engineers at Marshall Space Flight Center built a test rig that allowed the astronauts to roughly lay out the final ammonia lines (wrapped in white insulation, as seen in the photograph) with realistic attachment points days before the mission was scheduled to launch.

would be used. Multiple versions of each type were manufactured to allow for further problems.

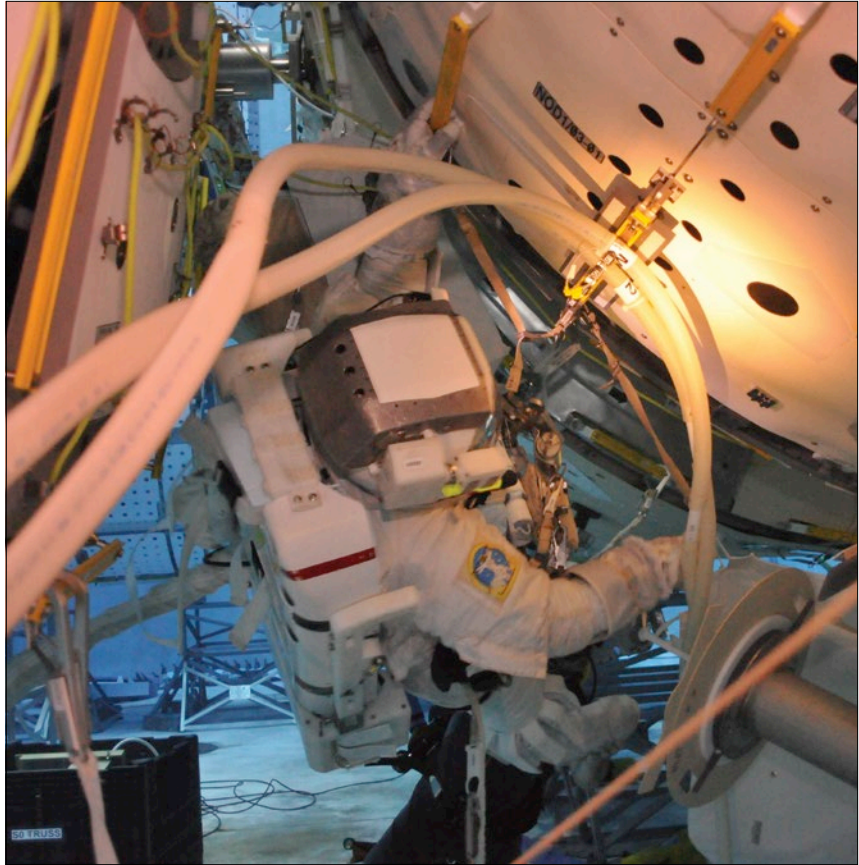
The new design really was simply an application of previous techniques. The method was previously used on the ISS, yet the length had never before been used either in space or on the ground. In fact, since time was short, leftover hoses from previous evaluations were to be used, thereby reducing the amount of testing. These hoses were dubbed “franken hoses” because they were put together from several pieces. The welding process was tried and true. In January, the new lines were tested to their bursting point of 26,900 mm Hg (520 psi). Although the updated braided hoses were also ready, ISS Program personnel decided to go with the franken hoses.

The franken hoses were being completed literally as the crew went into quarantine. Spacewalkers Bob Behnken and Nick Patrick left quarantine and flew to Huntsville, Alabama, where the testing equipment and hoses were located, and where the two astronauts would be able to handle the items in advance. In fact, engineers at Marshall Space Flight Center quickly built a test stand that roughly represented the attachment points (Figure 11). Engineers were concerned that the equipment would be too stiff, but the astronauts felt they could work with the lines. After familiarizing themselves with the lines, the crew packed the hoses into a special EVA bag for shipping to Kennedy Space Center where the items would be loaded onto Space Shuttle Atlantis.

Image courtesy of Art Thomason

## Training

Training began in earnest approximately 6 months prior to the planned mission launch. Several types of training were involved. Since the teams were composed of experienced flight controllers and flight directors, the training at this point was called “flight specific” in that it dealt with the actual mission instead of any generic skills. On the Space Shuttle side, the team—i.e., the flight control team and the astronauts—performed a number of simulations, primarily practicing launching, landing, and aborts. The ISS teams also trained. Flight controllers on the ISS side of the house simulated the spacewalks, as well as the berthing, moving, and activation of modules during approximately a dozen simulations (sims). A key series of sims for the ISS team was the powering down of half the systems, integrating the loop A or B ammonia lines, and activating Node 3 and Cupola modules. Owing to the complexity of this task, the EVA steps were role-played during these sims instead of having the actual astronauts perform the steps in the NBL at the same time. Several joints sims were conducted between the two program teams, especially for rendezvous and docking. The station training lead and the shuttle simulation supervisor were key members of the operations team. Not only did they ensure that the crew and flight control team were trained and ready for the mission, they also poked at the timeline or flight rules to look for any issues the team had not considered. For example, looking into the timeline or flight rules might reveal the team had not allowed enough time



**Figure 12.** Astronaut Robert (Bob) Behnken installs a clamp to hold down the ammonia lines during a training run in the NBL.

for an activity, or a flight rule that was perfect for a nominal situation completely fell apart if something went wrong. The trainers would throw numerous malfunctions at the flight control team. This helped that team gain the confidence needed to deal with real problems in space while remaining composed. Although the specific simulated failures may not occur during the mission, the team knew how to work the problems in a cool and integrated fashion. The flight directors worked closely with the station training lead and shuttle simulation supervisor to ensure the core elements of the

mission would be fully trained; however, the specifics were left to the training team.

As the months went on, the flight directors ensured the controllers worked seamlessly as a team and that the plans were ready for the real mission. Since everyone was so nervous about the ammonia lines, the sneaky training team even threw in a simulated ammonia leak during one of the training runs. The team worked through it in the simulation, but everyone realized the situation had not been thought through completely. Therefore, the team cleaned up the procedures and



**Figure 13.** The billowy white insulation surrounding the ammonia lines at the NBL mock-up. This insulation drove the decision earlier on how to move PMA3 so as to not interfere with the PMM. Note that when the bag that held the ammonia lines was opened in the pool, the lines would shoot out toward the bottom like a crazed jack-in-the-box due to the orientation of the mock-ups in the water. Due to the problems with ammonia lines, as described, the final flight units were not ready for the mission until a few days before the mission. The spacewalking crew members wanted to handle the final items so they would have an idea as to what to expect on orbit. Therefore, the final days before the launch, they flew to Huntsville, Alabama, where the lines were being manufactured. Not only did they handle the ammonia jumpers, they packed the specially designed bag. The packed hoses were then rushed to the launch pad and stored in the orbiter. The crew members flew back to their quarantine facility at Kennedy Space Center.

trained everyone with additional review and simulations.

A key part of the training was having the crew practice the spacewalks. The crew and EVA team, as well as the lead station flight director, conducted many dives in the NBL to practice the timelines. Although EVAs are always tricky, the ammonia lines were, once again, the biggest challenge (Figure 12). The crew needed to extensively

practice the installation in the NBL because the ammonia lines were long, stiff, and covered by bulky insulation (Figure 13). The team also tried to figure out how best to carry such long lines out to the worksite, and then unpack and install them. Imagine carrying four stiff 8-m (25-ft) long rubber garden hoses from the garage. Then imagine doing it in weightlessness. A new bag was designed to hold the hoses. The crew practiced, in the

water, how best to position and open the bag, and remove and install the lines without getting a big tangled hydra on orbit. Due to the presence of gravity in the NBL, the hoses tended to come springing out of the bag like a crazed jack-in-the-box—or even something more disturbing, like in a scene from the movie *Alien*—once the crew opened the bag on the bottom of the mock-up.

## The Making of a Crew Member

*Robert Behnken, Lead Spacewalker*

*STS-130/ISS-20A*

During the making of a mission into space, whether it is a short-duration, long-duration, first, or last flight, crew members need to strike a balance between taking enough ownership that they are ready for all the tasks they will face, but not taking so much ownership that they become too disappointed should the mission change before their eyes. NASA has plans for lots of exciting missions that have not been done, and none of us can do them all! For STS-130/ISS-20A and ISS Increment 22, the missions covered a wide range of exciting tasks right up until they were executed.

As a part of the many mission permutations, after the Columbia accident in 2003 and prior to the Space Shuttle Return to Flight in 2005, NASA built plans to keep the station populated in the face of an unpredictable shuttle launch schedule. I was part of a group of astronauts assigned to prepare for the ISS missions without a firm mission date. Our supervisor at that time was fellow astronaut and ISS veteran Peggy Whitson. I still remember her words to us as we began training: "The good news is you are all assigned to missions to the ISS. The bad news is I can't tell you when they will be or how you will get there!" Officially, we were known as the "ISS Training Pool" ... or "в бассейне" (literally "in the pool") to our cosmonaut friends. (They found this quite humorous. To them, it implied we were on vacation in a "swimming pool" while they were hard at work!) And so we started, knowing we were headed to space but not knowing whether we were preparing for shuttle or Soyuz flights. When foam insulation again separated from the external tank during the STS-114/ISS-LF-1 (Return to Flight mission) launch, the launch manifest continued to evolve and we did our best to prepare for all options.

Over the course of the next year and a half, those of us in the ISS Training Pool became certified operators and specialists on various ISS systems, continued our



**Figure 14.** Bob Behnken and Nick Patrick installing ammonia lines and associated insulating blanket during the second STS-130 spacewalk. Limited consumables dictated that the installation plan proceed precisely according to schedule to ensure enough clean-up time after the predicted ammonia leakage time frame.

study of the Russian language, and traveled to Star City to be trained on the Russian portion of the ISS. From time to time we would hear snippets from the training or the planning flight controllers on what NASA had in store for us, and we would receive congratulations from cosmonauts that had seen our names on future manifests (sometimes as their crewmates). Through it all, we tried to not get our hearts set on any particular solution and to prepare the best we could for spaceflights...however and whenever they came. Largely outside our day-to-day life as assigned astronauts, NASA continued to make progress on the challenges with the shuttle external tank, and the flight manifest began to stabilize. For those of us who were prepping in the ISS Training Pool for uncertain missions, things became a lot clearer. For me, it meant leaving the "swimming pool" and preparing for the longest shuttle-docked mission to the ISS and the first five-spacewalk mission to the ISS, and leaving behind a Soyuz flight to the space station in the Increment 22 time frame.

The shuttle manifest continued to remain relatively stable for the next year. In March 2008, my shuttle crew and I completed STS-123/ISS-1J/A, finished our post-flight activities, and began technical jobs back within the astronaut office. I was assigned to future program support



(vehicle development for exploration missions after space shuttle retirement), and was surprised late that year to learn that I was headed toward another shuttle mission on STS-130. After looking closely at the manifest, it became clear that this mission would likely be during Increment 22 in the time frame I would have been on board the ISS, had my path continued on the Soyuz route 2 years earlier.

As the rest of the chapter outlines, the assembly mission STS-130 and its associated hardware took a twisted route to its final incarnation, just like I did as a crew member. Over the years, the cupola was an on-again/off-again part of the ISS. Certainly no mission would be dedicated to delivering it, and much of the space station's primary function could be performed without it. But, in the end, the value of having an observation port for visiting vehicles carried it to orbit. Node 3 was relocated even before it was ever installed and, as described in the chapter, the number of little things that had to come together to make that possible is just amazing. The fact that they all came together on schedule to allow for module activation during the STS-130 mission was an added plus for our shuttle crew (although it wasn't something we could have our hearts set on). At one point during the ammonia flex line development and test sequence, when the schedule seemed particularly challenging, the idea of delaying install and activation to a future shuttle crew was considered. Having trained dozens of hours for these tasks in NASA's Neutral Buoyancy Laboratory (NBL) and assisted with the development of the hardware itself, both myself and my spacewalking partner Nick Patrick knew that this task would not be easy, even for us, and that it would be extremely challenging if someone else picked it up on short notice and tried to squeeze it into their already-packed mission timeline.

Module activations for new parts of the ISS delivered by space shuttle generally involved the same basic steps. One: move module from payload bay to ISS. Two: connect power and cooling. Three: gracefully incorporate the new hardware into the rest of the ISS system. For Node 3, Step 2 was above average in difficulty, and it was

the one being considered for transfer to a future flight if the ammonia flex line hardware was not available at launch time. The install required four stainless steel flex lines to be installed and then wrapped in a large insulating blanket. Normally it is pretty challenging if a spacewalk has to install something that is bigger than a crew member. In our case, this spacewalk had five big items, and keeping them under control simultaneously was even more challenging. After several months of development, Nick and I and the rest of our team had a pretty slick process for getting it all done and even looking graceful while we did it. Gone were the days of all the hardware falling to the floor of the NBL as the initial scene from our spacewalking show. As the lead spacewalker for STS-130, I remember being asked about the spacewalk content being moved to the next shuttle crew, and how some felt our crew should advocate to the ISS Program that we should keep the content. My input was that we should let the other crew try the install and see how they felt about taking this content on. As with the ISS training that I started years before for an uncertain mission, I felt we would execute whatever mission they eventually put in front of us whether or not it included ammonia flex lines and insulation. In the end, the follow-on crew members that attempted our "EVA 2" were the strongest advocates for STS-130 to keep the content. For them, 6 to 7 hours of wrestling ammonia lines and insulating blankets made it clear that this EVA had more than its share of blood, sweat, and tears to extract from the installation crew and, in their minds, they were happy to have it be ours!

During my time on orbit during STS-130, I had a great appreciation for all that had gone into the development of the mission (Figure 14). My discussion with the ISS commander regarding how we could task his crew to assist with our spacewalking preparations really drove home all the alternatives for which we had prepared. Having trained for that crew years before, I really understood what they could do for us and what we could do for them. In the end, both the Increment 22 and STS-130 crews were really proud to be a part of the mission.

## Fly

After an unusually lengthy and busy interval of preparation, it was finally time to fly. The road was long, but everyone was ready by February. The training was done. The multitude of programmatic reviews were complete at NASA, culminating in the Flight Readiness Review. The consoles were stocked with office supplies and extra food. The mission was scheduled to

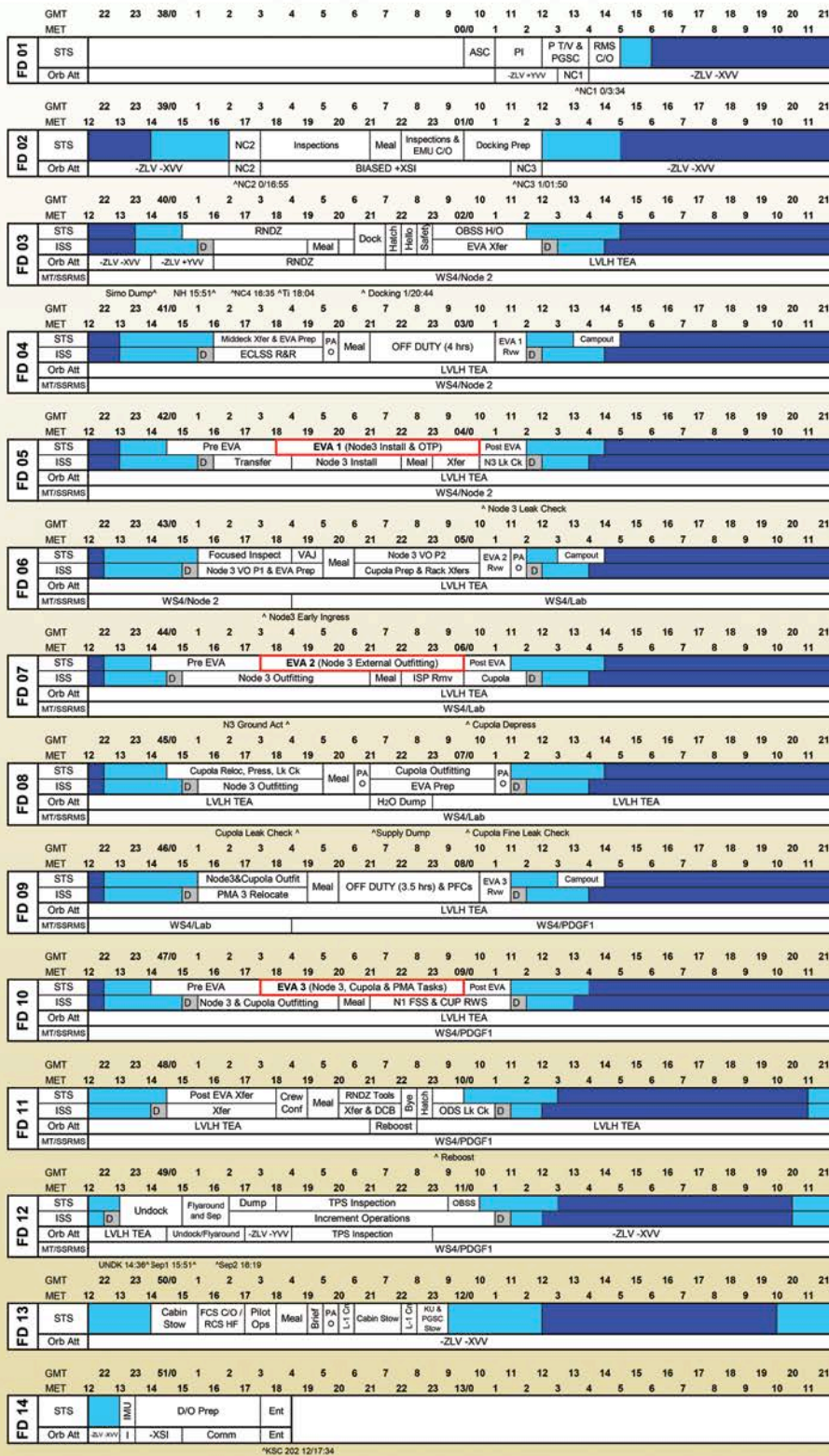
lift off on February 7, 2010, but was delayed due to poor weather. After a frenetic rush toward the mission for many years, there was an eerie calm—not unlike that slow creep up and over the first hill by a roller coaster before it takes a deep plunge. On February 8, Space Shuttle Endeavour launched perfectly (Figure 15). The final mission timeline and plan for the spacewalks are shown in Figures 16 and 17, respectively.

The Space Shuttle flight control team and its flight director monitored all the systems of the orbiter while preparing for rendezvous and docking. Things were a little quieter in the space station flight control room, since their part of the mission did not begin until final rendezvous. This gave the team time to make the last updates of procedures and provided an opportunity for the flight director to, once again, write down a



**Figure 15.** Launch of Space Shuttle Endeavour on February 8, 2010 (left). View of Endeavour's cargo bay from the ISS showing Node 3 with Cupola attached to the end. Due to the weight of the module, the rest of the cargo bay was empty.

**STS-130/20A Overview Timeline 13+1+2 (3 EVAs)  
GMTLO 038/09:39:39 Feb 7th, 2010**



**Figure 16.** The final overview timeline used to execute the 20A mission. Shuttle missions went by Flight Days with the first beginning at the moment of launch, even if the astronauts had been awake for a while. Twenty-four hours later, Flight Day 2 would begin, and so on. This graphic illustrates the major events that the Shuttle and ISS crews performed. Other key activities—just as “N3 ground act” (approximately 04:00 GMT on Flight Day 07), which was performed by the ground—appear above the Flight Day events. Note that the flight control team and the astronauts followed a much more detailed timeline as shown in Chapter 1, but this provides a quick view of the key events and how they relate to each other.



**Figure 17.** The final EVA timelines. EVA 1 consisted of preparing Node 3 for berthing. First the LTA power cable that powered the heaters was disconnected and bolts holding the module in the cargo bay were released. While the robotic arm was moving Node 3 from the orbiter cargo bay to its berthing spot, the crew performed other tasks such as positioning the bag that holds the ammonia hoses and removing the Orbital Replacement Unit Tool Platform. Once berthed, the spacewalking astronauts reconnected the heater cable as well as an avionics computer cable that would allow the computers to talk to the rest of the ISS systems. On EVA 2, the ammonia line of the “A” side of the cooling system was installed, and MLI (see Figure 14) was installed. This was repeated on the “B” side. The trunnions, which helped hold the module securely in the cargo bay, were then covered to prevent heat from leaking away from the module. During EVA 3, the Loop “B” cooling was fully integrated into the ISS system (Loops B QDs) followed by removal of the MLI that protected the Cupola and the releasing of locks that held the shutters in place during launch. The LTA heater cable, which was no longer needed since Node 3 systems were now fully functional, was removed. Other small tasks were performed on all three EVAs. The Get Ahead section on the last spacewalk consisted of a list of small tasks that were not required for STS-130/ISS-20A but that had to be performed at some point; time permitting, the EVA officer picked tasks from a list of various options for the crew to perform.

list of open issues—or worse, think about the things that they might have forgotten. However, issues constantly surfaced. Big and small trades were made at every turn. The Oxygen Generator Assembly failed a few days prior to the launch of Endeavour. The engineers pushed to have it fixed before the rack was relocated into Node 3. That way, if it couldn’t be reactivated, it was definitely related to the move and not the original, yet-to-be-diagnosed failure. The ISS team revised their timeline to squeeze in some repair work. A cooling valve on the Columbus module was not working properly, thus the team had to evaluate how it would impact the shutting down of the ammonia loops. Several

meetings were held where the flight controllers concluded that only minor impacts could be accommodated in the procedures. A recent longeron shadowing event (see Chapter 9) had ISS Program management concerned that damage may have been done to the mast. They wanted high-resolution photographs to inspect for possible damage. The windows on the orbiter’s aft flight deck offered the best viewing location. However, the ultraviolet window screen would have to be removed to produce the sharpest photographs—an option that violated safety rules. Then the team got word that the president of the United States, Barack Obama, wanted to talk to the crew during the mission. The president’s schedule

would drive the linkup, which meant the astronauts would not be speaking with the president during the prime part of their workday since it took place in the middle of the night, Eastern Standard Time. The flight directors began adjusting the schedule to make it work. Besides the public relations aspect, it would be a nice treat to give a hardworking crew during the mission.

The flight control team was used to working around these types of issues. By all standards, the mission was going smoothly. The training and hard work of numerous people over the years was paying off. The first significant issues with the intricate ballet of module movements came



**Figure 18.** The 7-m (23-ft) long duct extended through Node 3 and into the Cupola to ensure proper airflow. Pictured are NASA astronauts Jeffrey Williams (center), Expedition 22 commander; Terry Virtz (left), STS-130 pilot; and Nicholas Patrick, STS-130 mission specialist.

when the crew ingressed the Cupola on Day 6 of the mission to ready it for the relocation. To ensure adequate airflow with the 7 m (23 ft) duct (Figure 18), the crew used a device to measure the airflow and found it to be much less than expected. Per flight rules, fewer crew members were permitted in the area. Next, the crew went in and installed a protective cover over the Cupola to thermally shield it during the relocation. Unfortunately, the cover could not be installed on the ground and launched into position because the vibrations caused by the launch were greater than the structure of the Cupola could withstand if the cover was in place. When crew members installed the cover, they noted that the clearance

between the cover and some brackets was too small—a thin metal ruler barely fit between the bracket and the insulation. If the clearances were even tighter on the nadir port, the Cupola could not be mated.

The contingency teams, including Team 4 (see Chapter 20), roared to life to analyze the problem. There was only a small window of time before things such as the PMA3 relocation dropped off the mission if the ballet got backed up. The teams considered different options. Could they do the move without the cover? What was the expected clearance on the nadir port since the module had never actually been physically mated together? Would the motors have

enough force to bend the brackets without damaging the structure if there was interference? The root of the problem quickly became apparent: to save file size, the computer models did not include bolts since thousands of bolts added megabytes to each drawing. What seemed like a small issue became a significant wrinkle.

The mission was not placed on hold while that problem was being worked. While preparing Patrick's space suit for the second EVA, the team discovered that the fan speed of the water pump was far less than expected. If it failed during the spacewalk, it could jeopardize his life and cause the flight control team to abort the EVA.

Unfortunately, repairing the suit required two crew members for 2.5 hours, which translated into the need for a significant amount of schedule replanning.

It was common for the simulation team to be maligned for coming up with diabolical scenarios. Yet, their efforts paid off when, as if on cue, Patrick got a small spray of ammonia during the second EVA. Everyone knew what to do and how long it would take. The flight control team worked through the procedures, and no ammonia was detected in the atmosphere. Vindicated, the training lead knew his training had been successful.

After a number of meetings around the clock, the teams determined that there would be barely enough clearance for the Cupola to fit on Node 3 nadir. If enough clearance did not exist, it was likely some of the brackets would bend but nothing would break. This, however, was considered unlikely. The teams pressed ahead toward the relocation. After the second spacewalk, the Node 3 module was activated for the first time using half of the power and cooling systems (Figure 19). After the activation, one of the key Multiplexer/DeMultiplexers (MDMs) controlling Node 3 nadir Common Berthing Mechanism (CBM), where the cupola would be mated, failed into the diagnostic safe mode (see Chapter 5). While the flight control team tried to quickly interpret the cause, the flight director ensured the team didn't get too far behind on the timeline and that the most critical objectives could still be accomplished. After a power cycle, the MDM was operating again and preparations for the mating could



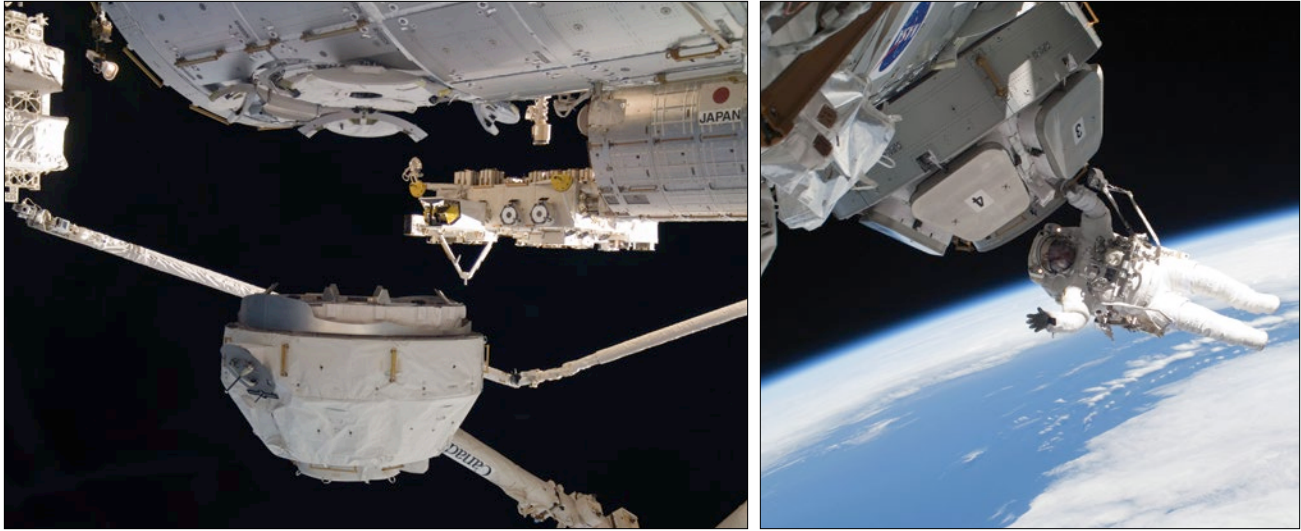
**Figure 19.** Flight Director Robert Dempsey and Capsule Communicator (i.e., CAPCOM) Hal Getzelman in Mission Control focus on activating Node 3 module during the STS-130/ISS-20A mission.

continue. However, this was not the only challenge keeping the Onboard Data and Information Network officers in particular, and the team in general, occupied. The computer system in the Columbus module had experienced an unknown failure and was not working.

Flight Day 8 arrived, and it was time to relocate the Cupola. Problems in the CBM—basically, the system of bolts used to fasten modules together—rarely occurred on orbit, so it came as a bit of a surprise when in Mission Control OSO saw an indication that one of the bolts had jammed while trying to detach the Cupola. After quick discussions with the engineering team, OSO and the flight director decided to force the bolt to push harder. The bolt released, but a second one jammed. And then a third. This scenario was completely unexpected. The ground team had to stop to assess the situation, and to avoid damage to the hardware. However, it was like having an automobile tire half

off, and not a good place to be in the long term. In real time, the team deduced that gravity caused the bolts to tighten unevenly during installation at Kennedy Space Center, unlike previous modules that were bolted together exclusively on orbit. Therefore, the forces on the bolt would be uneven as the Cupola was being de-mated (this is analogous to removing the adjacent lug nuts, rather than opposing nuts, while changing a tire). As in a simulation, the flight control methodically nudged and tweaked the bolts. Soon, the Cupola was free and moving to the Node (Figure 20). The clearances were fine, the MDM continued to operate, and the CBM bolts worked smoothly as the Cupola was firmly mated to the bottom of Node 3.

Since things were now running smoothly, the Space Shuttle Program and ISS Program teams agreed to use the extra mission day for the rack transfers. On the 8th day of the mission, the crew was like an army of ants, removing bolts that would hold

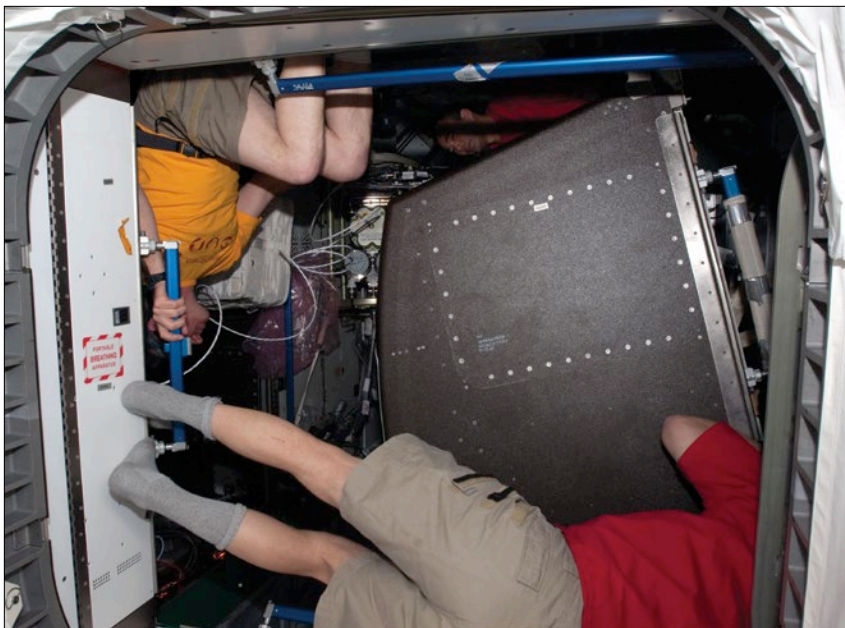


**Figure 20.** Cupola being maneuvered into position on the nadir side of Node 3 (left), and astronaut Patrick, during the third spacewalk, after removing the insulation that protected the module from launch until its heating system was operational (right).

things in place during the tremendous vibrations during launch, removing items stowed in Node 3, moving the life support racks and exercise equipment into place, and trying to secure all the elements. It was slow

work. Each rack was shut down and carefully moved to the new location (Figure 21). The flight control team then powered the system back up. Every rack experienced some small hiccup during the relocation—a

cable not connected properly, the software not exactly as it had been tested on the ground, air bubbles in the plumbing—and the team had to work through each issue. As with the OSO position, the ECLSS team had so much going on that two front room flight controllers had to work the various rack activities. Each system was so busy with its own activities. The flight director had to ensure everyone worked as a team in completing the critical activities on the timeline while deferring, and replanning, those that needed to be moved, and while working with the engineering support team and the Europeans on the various other working issues. The role of the flight director is not unlike that of a Chinese acrobat who balances several spinning plates on poles. Every shift presents a new wrinkle, such as when the lead EVA officer came down with food poisoning and had to go home for a while, creating yet one more issue for the flight director to balance and work through.



**Figure 21.** Astronauts maneuver one of the many racks relocated to Node 3 module during the mission. As two crew members pushed a rack into a place, a third crew member helped guide it. All the power, data, and cooling cables would then be mated.



**Figure 22.** President Barack Obama talks to the astronauts (seen in a video linkup in the top right of the picture) while students look on. Although the president could see the astronauts, no video was transmitted in other direction; therefore, the astronauts could not see what was happening at the White House.

Due to the length of the mission and the intense work being performed to that point, part of the 9th day of the flight was crew time off. At this time, the crew members get to rest and enjoy some views from the Cupola. But first, as soon as the crew members awoke, they had a linkup with the president (Figure 22). After a brief period of rest, the crew began preparing for the final spacewalk, which would take place the next day.

Analysis of imagery taken during the first spacewalk revealed that

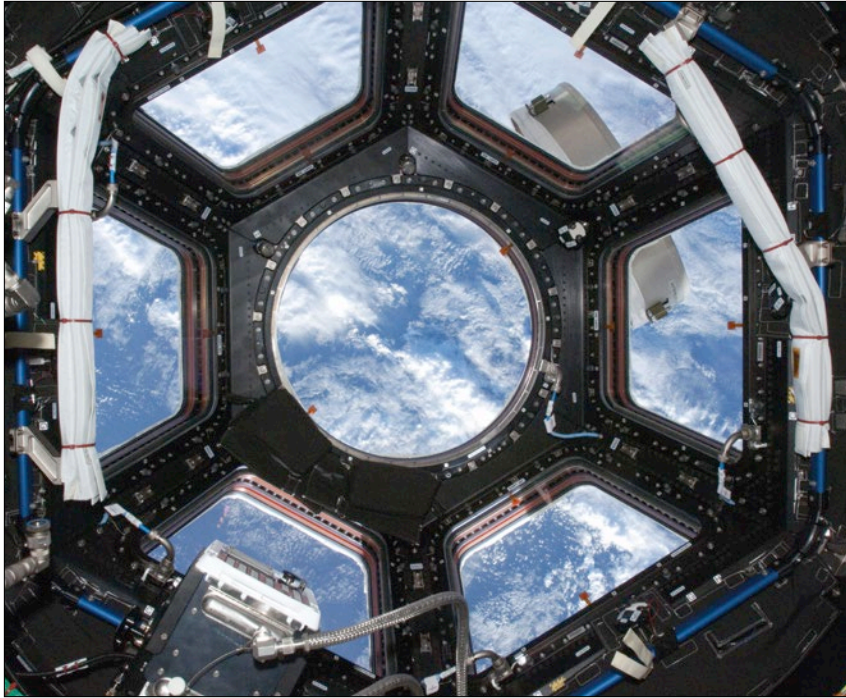
the clearance with the radiator and the PMA3 should be sufficient. Therefore, PMA3 was relocated to the end of Node 3. As an extra precaution, the radiator was slowly rotated as the Thermal Operations and Resources flight control team watched to ensure there would be no contact. The team confirmed that everything was good.

Without incident, EVA 3 integrated the B side of the ammonia lines, this time with no ammonia leak. Insulation was removed from the

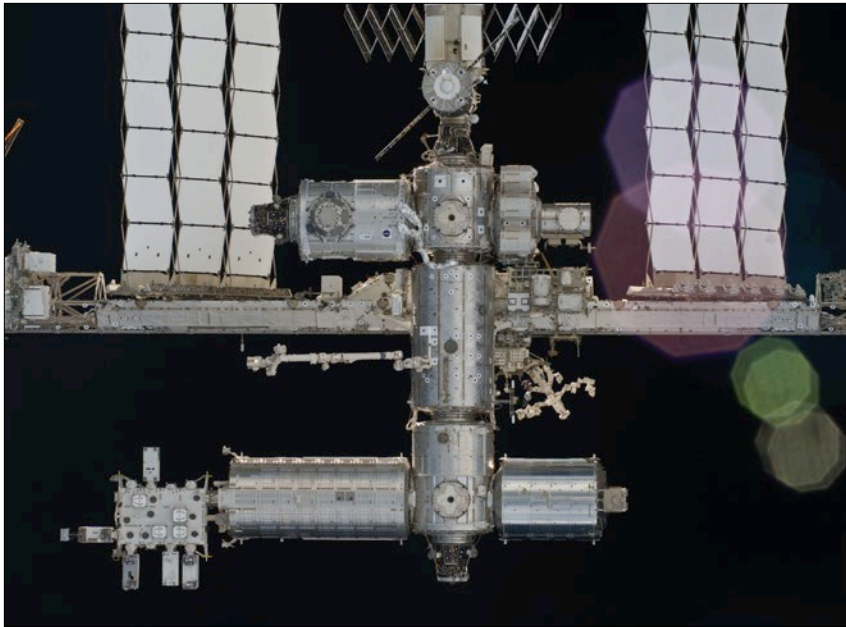
Cupola shutters during the spacewalk, and the windows were opened for the first time. Even in a business routinely filled with amazing visuals—a Space Shuttle launch, the ISS floating above the Earth, a person in a space suit floating among the heavens—the view from the Cupola was stunning (Figure 23).

As quickly as the storm began, the mission started to wind down. Although not every task was complete, it was time for the crew of Endeavour to undock and





**Figure 23.** View of Earth from the newly installed Cupola.



**Figure 24.** The underside of the ISS, as photographed by astronauts aboard the undocking shuttle, showing the newly installed Node 3 and the Cupola.

return home. Far more had been accomplished than had been planned for even a year prior to the mission. Endeavour undocked on February 20 and flew around the station. Photos were taken of the new installed module (Figure 24). The ISS crew took a much-needed break and then completed the outfitting of Node 3 and the Cupola over the next few weeks. On February 21, 2010, Endeavour made a flawless nighttime landing at Kennedy Space Center.

## Epilogue

The final task of any mission is to conduct a “Lessons Learned” review. Even though more than 100 shuttle flights had flown and dozens of ISS assembly missions had been conducted, NASA still learned from its mistakes. Every organization examined every step, from planning through training and into execution. The flight control team generated recommendations in each area and the flight director conducted a panel to determine which of those should be elevated and instituted in future missions. For example, it was agreed that all future spacewalks that entailed working with the ammonia lines would conduct some sort of contamination scenario in a simulation. But it was not all about criticism. Things that worked well were also highlighted so that other teams in the future can carry those practices forward to help ensure everything goes as smoothly, or better. This is a key part of the Flight Operations Directorate culture,



**Figure 25.** Lead OSO Kyle Brewer (left) and Lead ECLSS Officer John Garr (right) hang the 20A mission and module patches in the control room following the successful mission in 2010.

and this work ethic is reflected in the competence and teamwork statements in the Foundations (See Introduction).

The operations team conducts two major ceremonies after each mission. The first—and, to many, more meaningful—is the hanging of the plaque. Since the days of project Mercury, the flight director would pick the person, persons, or team that did the most outstanding job during the mission and let the honoree(s) hang the mission plaque (Figure 25) that had been displayed at the flight director’s console during the flight. Actually, two plaques—crew mission patch and ISS mission patch—were awarded for a given Space Shuttle assembly mission.

The second ceremony was held at Space Center Houston—the Johnson Space Center visitor center. Here, the crew showed video and narrated highlights from the mission. Various individual and team recognitions were awarded at this ceremony. However, a few minutes of recognition and thanks by the managers of the Space Shuttle and ISS Programs and the lead flight directors never fully reflected the immense amount of effort that went into the mission.

Although the ceremony marked the official end of one mission, the teams (Figure 26) were already poised to start the process all over again.

Later that year, when NASA was trying to figure out what to do after President Obama redirected the Constellation Program, some officials at the space agency wrote a press release stating that Node 3 could be detached from the space station and incorporated as part of a new vehicle that would go to an asteroid. Flight Director Robert Dempsey shook his head, laughed, and uttered the words that the whole team was thinking: “If they only knew how hard that would be.”



**Figure 26.** The seven flight directors and their teams that supported STS-130/ISS-20A. The ISS teams are pictured on the left (from top to bottom): the Galileo team on the prime shift (orbit 1), the Tungsten team (orbit 2), and the planning shift team led by Saturn Flight (orbit 3). The Space Shuttle teams are shown on the right (from top to bottom): Defiant (orbit 1), Viper (orbit 2), and Venture Flight (orbit 3). Amethyst Flight, with the launch or ascent team, is located bottom center.





## Chapter 5 **Systems:**

Command and  
Data Handling—  
The Brains  
of the International  
Space Station



Astronaut Susan Helms does a little "light reading" on the International Space Station.

**Brains. That is essentially what the Command and Data Handling (C&DH) system is for a spacecraft.**

Part of what is termed *avionics*, the C&DH system is responsible for the control of the primary systems of a spacecraft.

Early spacecraft used electrical and mechanical switches to operate the vehicle. From the beginning of the Space Age, up through the Space Shuttle era, the astronaut was a primary component of the C&DH system—adjusting dials as needed, throwing a switch to configure a system, and responding

when a component malfunctioned. Over time, computers played an ever-more-crucial role. Computers performed critical calculations that required accuracy and speed such as calculating the trajectory of a spacecraft as it descended to the lunar surface. The lunar module navigation computer possessed less than 40 kilobytes of memory and ran with a processing speed of 2.048 megahertz (MHz). By comparison, a basic Apple iPhone in 2014 contained 200 times more memory, ran 1,000 times faster, and produced pictures typically 2 megabytes (MB) in size. For the International Space Station (ISS), the

crew would no longer be a primary component of the C&DH system. Computers took over virtually every aspect of the vehicle's operations. Whereas the crew on the Space Shuttle interacted with the flight systems primarily through the use of switches or dials, nearly all aspects of the spacecraft operating system on the ISS are operated by computer interface and are therefore readily operable by the ground control team (i.e., the ground). This frees the crew to focus on research.

The C&DH system directs the operations of other systems via

“command” while moving, or handling, information around the vehicle. In essence, C&DH would be familiar to the average person as the computer network. A command is a set of instructions telling a computer to perform an action. For example, the print command is common among computer users on Earth. Spacecraft employ a variety of C&DH systems, depending on the functional need of the vehicle and its architecture. Complicating matters further, the ISS C&DH system—the largest such system ever operated in space—is in fact an amalgam of computer networks developed in multiple countries. Each segment, Russian and United States On-orbit Segment (USOS), has its own architecture bridged by Node 1, aptly named Unity. The USOS is split into the American, European, and Japanese modules, each with its own computer network. As part of its function, the C&DH system will detect failures—whether they involve a piece of hardware such as a valve or are in the computer system itself—and alert the crew and ground via alarm. Astronauts use a laptop called the Portable Computer System (PCS) to interface with the C&DH system. Using this laptop, they can run procedures that operate the vast majority of ISS systems, although the ground tries to perform most procedures to free up the crew for research. Due to its important role in operating the spacecraft, the C&DH system (including the PCS) is classified as critical and therefore requires robust hardware or redundant components to ensure proper operation as well as exhaustive software testing. Astronauts also have a separate

laptop called the Station Support Computer (SSC) upon which they can view the timeline and read procedures. SSCs are not linked to the C&DH system; because the SSCs provide only a support role (i.e., perform no critical function that would impact operating the ISS if an SSC failed), they are not considered critical. The SSC laptops connect to a Local Area Network (LAN) that would be familiar to anyone using laptops on a network. Payloads are generally controlled from the SSC. Through the SSC, astronauts can read email, access the internet, and use an Internet Protocol (IP) phone.

Initially, the Onboard Data Interfaces and Network (ODIN) officer operated the ISS C&DH system. Later, the ODIN function merged with the Communications and Tracking Officer function to form the Communications Radio Frequency Onboard Network Utilization Specialist (CRONUS) position. ODIN was supported in the back room by a resource avionics engineer. Although the SSCs are computers, they are not part of the C&DH system. Rather, the SSCs are handled by the PLugin-plan and UTILization Officer flight control position (see Introduction)—also known as PLUTO—and are not discussed here.

## Overview

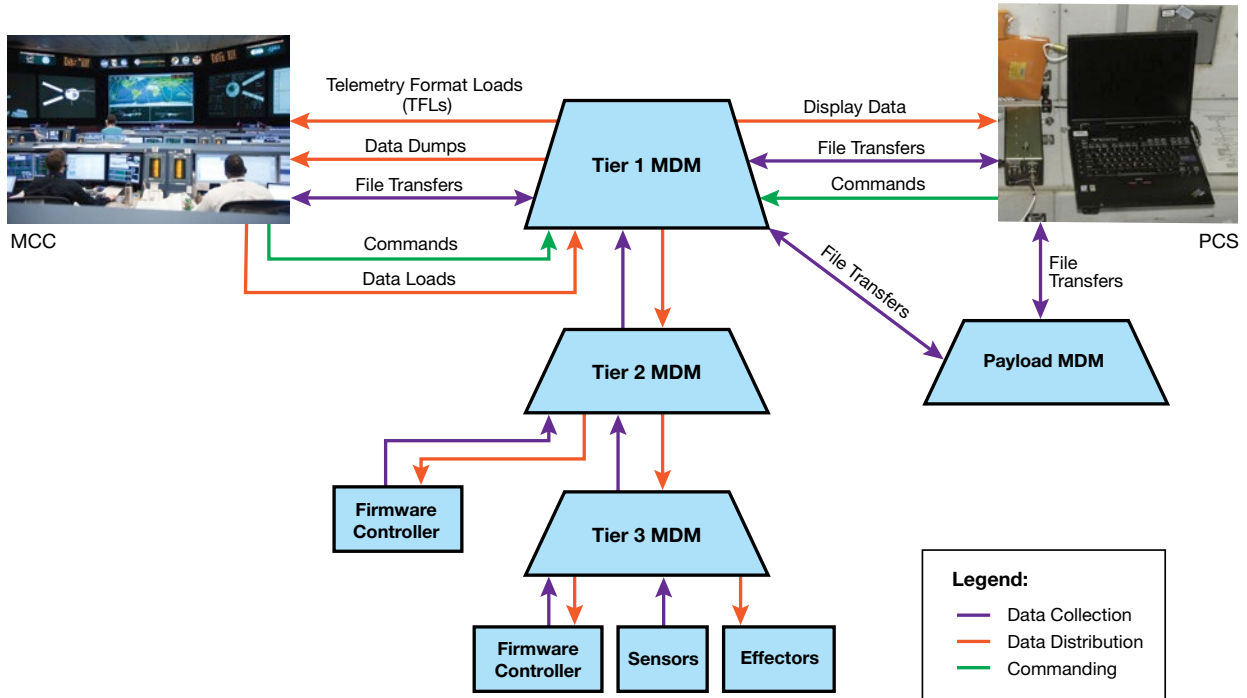
The USOS C&DH system consists primarily of 46 nearly identical computers networked into a top-down tiered structure, as illustrated in Figure 1. At the top of the pyramid is the Command and Control System (CCS), a triply redundant set of computers located in the Laboratory

Module that act as the brains of the USOS. Only one computer controls the system at a given time; if that computer fails, the second or third will take over operations. Due to the critical role of the CCS, three computers are required to ensure that multiple failures would not disrupt the control of the vehicle. The ground directly interfaces with the CCS via uplinked commands through the Communication and Tracking (C&T) system (see Chapter 13), whereas the crew can interact using a PCS. The CCS interfaces directly with the top-level computer on the Russian Segment known as the Service Module Central Computer (SMCC), as well as the computers in the European and Japanese modules.

The local tier (Tier 2) is located below the control tier. Computers at the local level control most spacecraft functions as well as the partner modules. Computers inside the ISS control such functions as the regenerative life support systems, ventilation, and temperature control while those on the exterior control heat rejection and the giant solar arrays. Another Tier 2 function is that of Guidance, Navigation, and Control (GNC), which drives the Control Moment Gyros while calculating the trajectory of the ISS using Global Positioning Satellite (GPS) sensors. Although still important, the Tier 2 computers are not as critical as the CCS and, therefore, have only a single backup in case of failure.

At the bottom of the triangle is the user tier, indicated as Tier 3. This tier is responsible for control of all sensors and end effectors that are wired to computer cards within the

## CDC Tier Interfaces



**Figure 1.** Representation of the USOS C&DH system illustrating the tiered nature of the computer system. Tier 1 (the top tier) is the control tier, directing (red lines) all the lower-level computers. Data, or telemetry (purple lines), rise from the lower tiers back to the top where it is radioed to the ground control team or sent to the crew's portable computer system. Tier 2 (the local tier) is where major functions such as guidance or thermal control are performed. All the sensors, fans, pumps, valves, etc. are controlled at Tier 3 (the user tier).

Tier 3 Multiplexer/DeMultiplexers (MDMs). Sensors include devices that can measure the carbon dioxide or oxygen level of the crew's atmosphere, the pressure inside a cooling loop, the speed of a fan, or the temperature of something. These devices are wired to an Input/Output (I/O) card in the computer. The value read by the sensor is transmitted to the card, which the computer will output to the Tier 2 MDM above it, where it is passed to the Command & Control (C&C) MDM for downlink to the ground. End effectors are items with moving parts, such as a switch or a motor, to effect a change. Some end effectors actually

fire pyrotechnics (i.e., explosives) such as those used to release straps holding collapsed radiators in place for launch. Solenoid Driver Output Cards provide the interface between the MDM and the end effectors. When power is applied to the card, a solenoid will physically move to push or pull an item such as a valve into position. The ISS has thousands of these sensors and effectors, and almost all are replaceable on orbit if a repair is required. The Remote Power Control Modules (RPCMs), which are effectively circuit breakers that can be opened or closed via computer, are the most common type of effectors.

Robustness at the user tier level (Tier 3) is achieved through redundancy of the systems. For example, a critical system may have two independent power feeds so that no interruption of electricity occurs if one power feed fails. Another example is where two separate heaters exist when only one would ever be needed. Tier 3 computers do not have backup MDMs since the systems themselves have layers of redundancy to protect against critical failures; of course, spare boxes are available on orbit to replace failed boxes. A summary of all the tier computers is provided in Table 1.



**Table 1.** A Summary of the Computers and their Functions on the ISS

Multiplexer/ DeMultiplexer	Configuration	Major Software Functions
<b>TIER 1</b>		
C&C-1 C&C-2 C&C-3	<ul style="list-style-type: none"> <li>• Three fully redundant MDMs</li> <li>• All powered on</li> <li>• One operating as Primary</li> <li>• Located internal to US Lab</li> </ul>	<ul style="list-style-type: none"> <li>• Process commands from Mission Control Center-Houston and PCS provide telemetry to Mission Control Center-Houston and data to PCS, redundancy management for Tier 2 MDMs, and time management. They also control station modes, software interface to International Partners, and File Transfer management.</li> <li>• Emergency and Vehicle Safing: Execute commands to safe vehicle in response to an emergency event</li> <li>• Manage S-band, Ku-band, ultra-high frequency, audio, video, control high-rate data link, and access mass storage device in support Communications Outage Recorder function</li> <li>• Control Lab Direct Current (DC)-to-DC Converter Units, control RPCM for S0 and External (EXT) MDMs, control rack power based on switch position, execute power and thermal load sheds</li> <li>• Control and coordinate attitude control handovers</li> <li>• Interface to Robotics Work Station</li> </ul>
<b>TIER 2</b>		
<b>Connected to Command &amp; Control</b>		
Internal (INT)-1 INT-2	<ul style="list-style-type: none"> <li>• Two fully redundant MDMs</li> <li>• One powered on</li> <li>• One operating as Primary</li> <li>• Located internal to US Lab</li> </ul>	<ul style="list-style-type: none"> <li>• Control most Lab RPCMs</li> <li>• Monitor and control of Internal Thermal Control System (ITCS) in Lab/Node 2 including failure and leak detection/response</li> <li>• Atmospheric control, water recovery, fire detection, temperature control</li> <li>• Common Berthing Mechanism (CBM) control and safing</li> </ul>
EXT-1 EXT-2	<ul style="list-style-type: none"> <li>• Two fully redundant MDMs</li> <li>• One powered on</li> <li>• One operating as Primary</li> <li>• Located on S0 Truss</li> </ul>	<ul style="list-style-type: none"> <li>• High-level control of Solar Array Rotary Joint</li> <li>• High-level control of External Thermal Control System and Thermal Radiator Rotary Joint</li> <li>• Provides high-level control of: Structural Dynamic Measurement System, Common Attachment System, Segment-Segment Attachment System</li> <li>• Control of Mobile Transporter</li> </ul>
GNC-1 GNC-2	<ul style="list-style-type: none"> <li>• Two fully redundant MDMs</li> <li>• Both powered on</li> <li>• One operating as Primary</li> <li>• Located internal to US Lab</li> </ul>	<ul style="list-style-type: none"> <li>• Provide non-propulsive attitude control by controlling Control Moment Gyros; generate and supply pointing data</li> </ul>
Power Module Control Unit (PMCU)-1 PMCU-2	<ul style="list-style-type: none"> <li>• Two fully redundant MDMs</li> <li>• One powered on</li> <li>• One operating as Primary</li> <li>• Located internal to US Lab</li> </ul>	<ul style="list-style-type: none"> <li>• Monitor and control of Main Bus Switching Units and most Station DC-to-DC Converter Units, provides gateway for PhotoVoltaic Module equipment, provides solar array pointing data, monitor and control of some Lab RPCMs, control RPCM for PL-2 MDM</li> <li>• Control of PhotoVoltaic Control Unit (PVCU) MDMs</li> </ul>
Payload (PL)-1 PL-2	<ul style="list-style-type: none"> <li>• Two fully redundant MDMs</li> <li>• Both powered on</li> <li>• One operating as Primary</li> <li>• Located internal to US Lab</li> </ul>	<ul style="list-style-type: none"> <li>• Payload software support</li> <li>• Configure, monitor, and control: Automated Payload Switch and Payload Ethernet Hub Gateway</li> </ul>
Habitation Control Zone (HCZ)† - 1 HCZ-2	<ul style="list-style-type: none"> <li>• Two fully redundant MDMs</li> <li>• One powered on</li> <li>• One operating as Primary</li> <li>• Located internal to Node 3</li> </ul>	<ul style="list-style-type: none"> <li>• RPCM control</li> <li>• Monitor and control of Node 3 ITCS including failure and leak monitoring</li> <li>• Atmospheric control, water recovery, fire detection, temperature control, regenerative life support systems</li> <li>• CBM control and safing</li> </ul>

† Initially intended to control the Habitation Module, these MDMs were repurposed after that module was deleted from the program.

(continued next page)

**Table 1.** (continued)

<b>TIER 3</b>		
<b>Connected to Internal Multiplexer/DeMultiplexer</b>		
Node 1 (N1)	<ul style="list-style-type: none"> <li>• Two partially redundant MDMs</li> <li>• Both powered on</li> <li>• One operating as Primary, one as Secondary</li> <li>• Located on PMA-1</li> <li>• Also an connected to C&amp;C MDM</li> </ul>	<ul style="list-style-type: none"> <li>• Node 1 monitor and control: fire detection and isolation</li> <li>• RPCM control</li> <li>• Heater control, cabin pressure monitoring</li> <li>• Control CBM</li> <li>• Recovery of USOS command and control interface (Mighty Mouse)</li> </ul>
Laboratory-1	<ul style="list-style-type: none"> <li>• Located internal to US Lab</li> </ul>	<ul style="list-style-type: none"> <li>• Smoke detector monitoring, Common Cabin Air Assembly (CCAA) control, InterModule Ventilation (IMV) control</li> <li>• Low Temperature Loop (LTL) temperature control, Loop Crossover Assembly (LCA) valve control, rack flow control</li> <li>• Rack power switch monitoring</li> </ul>
Laboratory-2	<ul style="list-style-type: none"> <li>• Located internal to US Lab</li> </ul>	<ul style="list-style-type: none"> <li>• Smoke detector monitoring, CCAA control, IMV control</li> <li>• Moderate Temperature Loop (MTL) temperature control, LCA valve control, rack flow control</li> <li>• Rack power switch monitoring</li> <li>• Lab Caution &amp; Warning (C&amp;W) panel control</li> </ul>
Laboratory-3	<ul style="list-style-type: none"> <li>• Located internal to US Lab</li> </ul>	<ul style="list-style-type: none"> <li>• Air revitalization, vacuum system control</li> <li>• ITCS rack flow control</li> <li>• Rack power switch monitoring</li> </ul>
Airlock	<ul style="list-style-type: none"> <li>• Located internal to Airlock</li> </ul>	<ul style="list-style-type: none"> <li>• Airlock smoke detector monitoring, CCAA, IMV control, depress pump control, Battery Charger Assembly, Umbilical Interface Assembly</li> </ul>
Node 2 (N2)	<ul style="list-style-type: none"> <li>• Located internal to Node 2</li> </ul>	<ul style="list-style-type: none"> <li>• Node 2 smoke detector monitoring, CCAA, pressure monitoring, IMV control</li> <li>• Node 2 control and monitoring</li> <li>• Rack power switch monitoring</li> <li>• Node 2 C&amp;W panel control (N2-2 MDM)</li> <li>• Japanese Experiment Module C&amp;W panel control (N2-1 MDM)</li> </ul>
<b>Connected to External Multiplexer/DeMultiplexer</b>		
S0-1, S0-2	<ul style="list-style-type: none"> <li>• Two partially redundant MDMs</li> <li>• Both powered on</li> <li>• Operating as bus controller (BC) on different buses</li> <li>• Located on S0 Truss</li> </ul>	<ul style="list-style-type: none"> <li>• Structural Dynamic Measurement System</li> <li>• Heat exchanger control, some External Thermal Control System monitoring and Failure Detection, Isolation, and Recovery</li> <li>• S0 RPCM control</li> </ul>
S1-1, S1-2, P1-1, P1-2	<ul style="list-style-type: none"> <li>• Two partially redundant MDMs</li> <li>• Both powered on</li> <li>• Operating as BC on different buses</li> <li>• Located on S1/P1 Truss</li> </ul>	<ul style="list-style-type: none"> <li>• Thermal Radiator Rotary Joint control, S1-1/P1-2 MDMs provide primary External Thermal Control System insight, S1-2/P1-1 MDMs provide External Thermal Control System pump commanding</li> <li>• S1/P1 RPCM control, S1 MDMs control RPCMs for S1 and Starboard Thermal Radiator MDMs, P1 MDMs control RPCM for P1 MDMs</li> </ul>
S3-1, S3-2, P3-1, P3-2	<ul style="list-style-type: none"> <li>• Two partially redundant MDMs</li> <li>• Both powered on</li> <li>• Operating as BC on different buses</li> <li>• Located on S3/P3 Truss</li> </ul>	<ul style="list-style-type: none"> <li>• Solar Array Rotary Joint control, S3/P3 RPCM control, S3 MDMs controls RPCMs for S3 MDMs, P3 MDMs controls RPCMs for P3 MDMs</li> </ul>
Starboard Thermal Radiator, Port Thermal Radiator	<ul style="list-style-type: none"> <li>• Located on S1/P1 Truss</li> </ul>	<ul style="list-style-type: none"> <li>• Radiator beam insight and commanding</li> </ul>

(continued next page)

Table 1. (continued)

Connected to Power Module Control Unit Multiplexer/DeMultiplexer		
P4 PVCU-2A, P4 PVCU-4A S4-PVCU-1A S4-PVCU-3A P6-PVCU-2B P6-PVCU-4B S6-PVCU-1B S6-PVCU-3B	<ul style="list-style-type: none"> <li>• Two fully redundant MDMs</li> <li>• Both powered on</li> <li>• One operating as Primary</li> <li>• Located on respective Truss Segment</li> </ul>	<ul style="list-style-type: none"> <li>• Control power generation through pointing of Beta Gimbal Assemblies, control energy storage by control of Battery Charge/Discharge Units, monitor battery units, control, monitor, and provide control for Sequential Shunt Units and DC Switching Units</li> <li>• Control PhotoVoltaic Thermal Control System</li> </ul>
Connected to Habitation Control Zone Multiplexer/DeMultiplexer		
Node 3-1 (N3-1) N3-2	<ul style="list-style-type: none"> <li>• Located internal to Node 3</li> <li>• No redundancy</li> </ul>	<ul style="list-style-type: none"> <li>• Node 3 smoke detector monitoring, CCAA, pressure monitoring, IMV control</li> <li>• Node 3 MTL [N3-1]/LTL [N3-2] control and monitoring</li> <li>• Rack power switch monitoring</li> <li>• Node 3 C&amp;W panel control [N3-1 MDM]</li> </ul>

The European and Japanese modules each have their own computer systems that monitor and control all the systems in that module. The primary computers in each module are Tier 2 computers underneath the CCS. On the Russian Segment, the computer system is also broken down by tiers, but with less resolution. The main computer on the Russian Segment consists of the SMCC, which is analogous to the C&C system on the USOS. The main connection between the segments for data transfer is between the SMCC and the CCS. Although the SMCC contains three computers, these systems are not redundant boxes such as the CCS, but are rather a voting block similar to the General Purpose Computers (GPCs) on the Space Shuttle. Specifically, all three computers are always operating, processing commands and telemetry; however, if one reports a discrepancy, it is voted out and the other(s) continue(s) without the malfunctioning computer. The three Service Module Terminal Computers (SMTCs) operate in a similar fashion. The SMTCs connect to, and parallel, the USOS GNC computers. Other functions such as thermal control and

life support are spread out between the SMCC and SMTC systems.

### Multiplexer/DeMultiplexer

The MDM is at the core of the C&DH system on the USOS. Multiplexing is the process of taking data from many inputs and formatting them into a single continuous data stream. Demultiplexing is the reciprocal process of breaking a single stream into its basic components and transmitting the resulting data to the required end user. These data, or telemetry, contain the details of everything about the spacecraft ranging from temperatures of items (e.g., the fragile aluminum shell of the ISS), to angles of articulating components such as the solar arrays, to the attitude and velocity of the vehicle. It also includes the health and status of the MDMs.

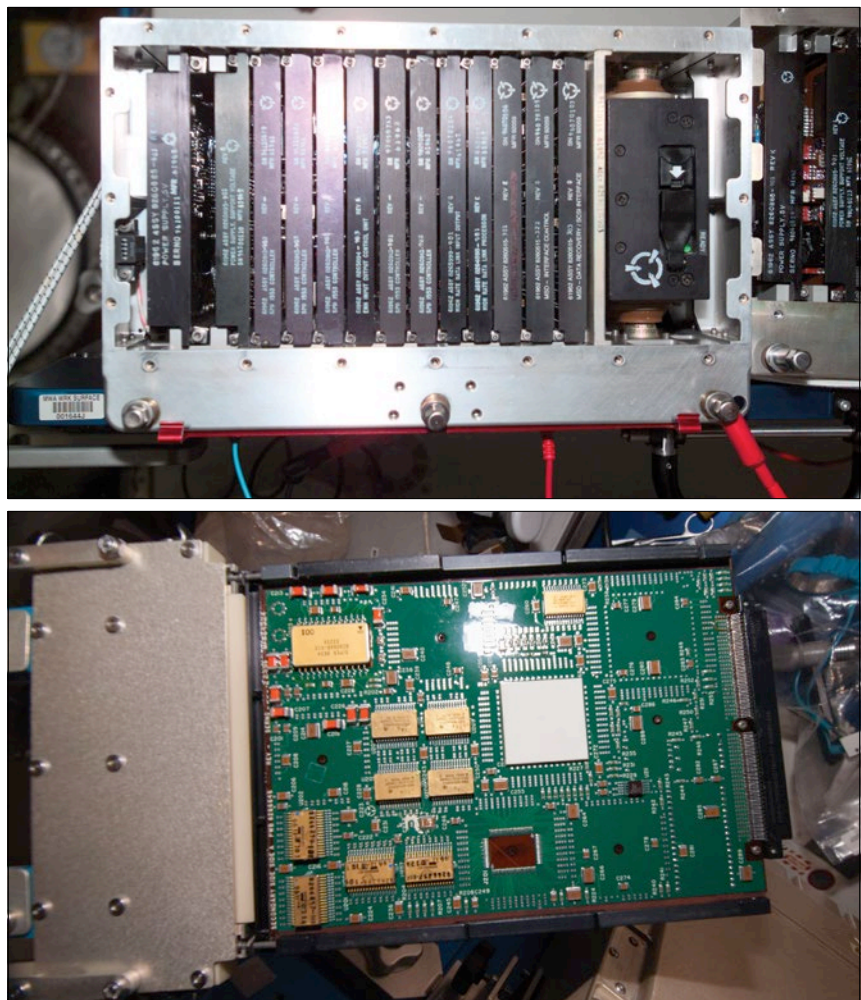
An Intel 386 processor is at the heart of most MDMs. In an age of ever-more-powerful computer chips, this may seem ridiculously antiquated; however, this processor has enough computing power to get the job done. The lag behind current technology is due to the life cycle of computer

hardware development. Designing a spacecraft, testing and certifying an item for the space environment, building the hardware, and finally implementing on orbit takes many years. For computers that evolve yearly, this may overlap several generations of improvements. Since the faster chips are also thinner, they are much more susceptible to radiation interference in space causing the computer to lock up. This is not acceptable for the MDMs that control critical functions. There is generally little need or ability to upgrade the MDMs in most spacecraft, once the MDMs are in operation. However, the ISS MDMs were designed such that improvements could be incorporated if the need and money were available. The major limitation of the MDM is not the processing speed, but rather the memory available and the communications network. As some of the functions on the ISS evolved, especially the Ku communications systems (see Chapter 13), the CCS processor was upgraded to the Enhanced Processor and Integrated Communications card, which contained a Pentium chip.

**Table 2.** Comparison between the Standard MDM with the Enhanced Unit. In recent years, the C&C, GNC, PL, and EXT MDMs were upgraded as indicated in parentheses. See also Chapter 6.

Component	Function	Standard MDM	Enhanced MDM
80386 Processor Chip (Pentium 266 MMX)	Microprocessor (CPU) of the MDM	12 MHz	16 MHz (144 MHz)
Electrically Erasable Programmable Read-Only Memory	Nonvolatile storage area for the MDM and application software. This includes the MDM boot-up software.	1 MB	1 MB
Dynamic Random Access Memory	Volatile storage area where applications execute	2 MB	8 MB (64 MB)
Analog to Digital Chip Converter	Converts analog data received from I/O cards to digital data	Present	Present, but only to measure the internal temperature of the MDM
Math Coprocessor	Chip that assists the CPU in performing certain types of operations increasing the computer's speed	Not present	Present

The ISS MDMs come in two styles: standard and enhanced. Table 2 lists the basic properties of the ISS MDMs. The main difference is that the enhanced ones have a bit more memory (8 MB versus 2 MB), a faster processor (16 MHz vs 12 MHz), and can hold an additional memory card whereas the others cannot. The standard MDMs come in several sizes depending on how many I/O cards they can hold; i.e., 4, 10, or 16. MDMs within a class are interchangeable. Whole boxes are not generally retained as spares on orbit, but a few generic MDMs or spare cards are present. If a specific MDM experiences a fatal failure, a new box or card is installed and the appropriate software is installed. Not all enhanced boxes contain a hard drive. Tier 1 and Tier 2 MDMs are of the enhanced type. Since the standard MDMs do not need to read data off of a disk or store data, they do not require hard drives and, at that point, resemble a tablet more than a desktop PC. All the system software is resident in nonvolatile electronic memory on a circuit card. Figure 2 shows the layout of a basic MDM. Two of the enhanced MDMs—C&C and Payload



**Figure 2.** Photographs of an MDM. The top picture shows the MDM with all the various computer cards. The SSMMU is the wide device at the right of the card set. A picture of the computer cards is shown in the bottom image.

(PL)—come with additional memory storage. Initially, this storage was in the form of a 300 MB Mass Storage Disk (MSD). This was actually a spinning magnetic disk commonly found in most desktops. In 2001, Solid State Mass Memory Units (SSMMUs) with 2 MB flash memory cards replaced the disks. A High Rate Data Link card provides the interface to the MSD/SSMMU.

Since sensors come in a variety of types (e.g., analog, digital), the Tier 3 MDMs contain a number of I/O computer cards that transmit the data. The measurement of temperature or voltage are examples of analog data in that the sensor will read the value (e.g., 15.3°C [59.5°F]) and transmit that number to the computer. Data that are discrete in that they report binary data use digital cards. Of course, even the analog data are sampled and digitized—like music is sampled and digitized on a compact disc—so that the data may easily be transmitted to the ground. These cards are summarized in Table 3.

MDMs communicate over a network of busses that consist of twisted copper lines using the Military Standard 1553 communication protocol. This protocol may be a bit

## When Computers Crash

The C&C and PL MDMs were launched in 2001 with MSDs. Primary use for the disk was to store the operating software that could not fit into the nonvolatile memory. The C&C MSD also functioned as a telemetry recorder for later playback when the ISS was out of communication with the ground, as well as a staging place for uplinking or downlinking data files. NASA accelerated a planned upgrade to newer SSMMUs in the summer of 2001 after the hard drives on all three C&C MDMs failed during the Space Transportation System (STS)-100/ISS-6A mission due to damage on the delicate surface of the disks. In 2004, the CCS software was redesigned to fit as a zipped file in nonvolatile memory so that the system could almost always boot up for most failures. In the initial design, display data needed for the crew's PCS displays resided as files on the C&C MSD, which were transferred over when the crew activated that display. However, these displays would not work with a failed MSD, so they were moved to spare memory of the High Rate Data Link card. When the MSDs failed during and after STS-100/ISS-6A, identical units from the PL MDMs were removed, installed into the C&C MDMs, and reformatted. The CCS software was then completely reloaded onto the drives.

old, but it is well tested and robust, and has been used on aircraft and military ships. Originally, the design of the Space Station Freedom, which was to use as much groundbreaking technology as possible, called for a fiber-optic computer network. However, when this proved too costly, copper cables that did limit

data transfer rates were adopted. The copper wire busses actually consist of two separate-but-identical cables called channels. If an MDM is having trouble talking to another device on one channel, the system will switch to another channel and try talking to that channel. Each channel's wire is also physically separated from the others.

**Table 3.** Summary of Standard MDM Card Properties

Input/Output Card	Typical Use	Number of Channels	Number of Cards on the International Space Station
Low-level Analog	Reads analog voltage or supplies the current source to measure the drop across a Resistive Temperature Device. Mainly used for precise temperature measurements.	32	57
High-level Analog	Reads analog sensors (pressure, flow rate, speed).	32	24
Analog Input/Output	Drives analog effectors (valves and switch positions) and reads voltages.	16	22
Digital Input/Output	Reads discrete sensors (valve and switch positions).	32	54
Solenoid Driver Output	Activates and deactivates solenoids and valves.	16	26

This provides redundancy throughout the network, protecting against such problems as high-velocity debris hitting the ISS or a fire that may disable a single channel.

Data are transmitted at multiple rates at the same time (0.1 Hz, 1 Hz, and 10 Hz), the higher speeds being for the most critical items. A controlling MDM is called a bus controller (BC) as it sends out commands and timing signals to all the devices on the bus and, in turn, reads the status telemetry that is transmitted by the client MDMs. Any device that is listening on the bus is known as a Remote Terminal (RT). The BC will send a command to an RT and the RT will, in turn, report the status of that command back to the BC. Thus, a command to open a valve might have to travel from the ground, over to White Sands Test Facility, up through the Tracking Data Relay Satellite System (see Chapter 13) and over to the ISS on S-band, and be received by the C&C MDM, transmitted to a Tier 2 MDM, and routed by the Tier 3 computer to the destination device before the action takes place. The status of the command on the RT is then routed along the reverse path to the flight controller's computer display—a process that must occur within seconds of sending the command.

The MDMs have several different operating states, but generally there are three main ones. The first is an interim state called Standby. After booting up, the MDM is ready to perform its role but is not actually doing anything. This is similar to a desktop computer having booted up but with no applications having been launched. At this point, the MDM is a remote terminal on

the bus, listening for commands. Some MDMs will transition to the Operational state automatically, whereas others require commanding. At this point, the MDM can exchange commands and telemetry between the lower computers or sensors on the busses underneath it, which means it is now the BC and is fully operational. Where there are redundant MDMs, only one can be a BC; the other MDM stays in Standby or Backup. As with earthbound computers, MDMs can fail at any time; however, due to extensive testing, such failures are rare. If the computer hardware fails or locks up, the computer is no longer a BC. If the software detects something wrong (e.g., a numerical value out of valid range), rather than lock up in an analogous “blue screen of death,” the MDM will usually automatically enter the Diagnostic state. This is similar to the safe mode on most desktops or laptops. In this state, the flight control team can look at health and status indicators to determine the problem. Generally, these errors are transient mistakes fixed by patching computer code or rebooting.

The C&C MDMs are configured as an operational Primary, a Backup ready to take over instantly, and a Standby. This is unlike the Russian system where multiple duplicate units run simultaneously, comparing data and voting on the results. If the Primary should fail or be commanded out of its role by the ground control team, the Backup would take over almost instantaneously. Whereas some reconfiguration of the system would be required, most critical functions are ready to take control. Some configuration can be commanded to the Backup while

additional status information is routinely “check pointed” between the MDMs to ensure a smooth and expeditious transition. The Standby would take over directly as Primary if the other two MDMs should fail; however, additional configuration is required since no check point data or configuration is available in the Standby mode. (Although exchanging check point data is efficient in keeping computers in synchronization, it can potentially propagate some software error and therefore is blocked to the Standby.) However, the nominal case would be for the MDM to transition to the Backup role after a Primary MDM has failed or been commanded out of operations automatically, where the operators would then configure it as a Backup.

Time is one of the most critical parameters on the ISS for several reasons. First, time is critical for knowing the location of the ISS in its orbit. Traveling at a speed of nearly 8 kilometers/second (5 miles/second), a few seconds of error can quickly turn into large uncertainties in distance. Location accuracy is crucial when another vehicle is coming to the ISS or for pointing the Ku antenna precisely at a Tracking and Data Relay Satellite. Second, with such a large number of computers, it is important that information is exchanged carefully. The CCS acts as the global timekeeper on the ISS. Basically, it sets the time, and all other computers in the C&DH system synchronize to it. Although computers can maintain time fairly accurately, no two oscillators behave exactly the same. The oscillator essentially acts like a clock pendulum. Two computers

that are synchronized will eventually drift apart as the “pendulum swings” of their oscillator are different. For the computers used on the ISS, the difference is on the order of milliseconds. Still, information can get garbled as it passes back and forth due to these differences. For example, a command might not reach its correct destination because one computer is trying to pass it to a second computer that is not ready to receive it. If an MDM gets ahead of or behind the CCS, it will adjust its pendulum swing in the oscillator to drift back to the correct time before the difference becomes too large.

Upon boot up, the default time in the C&C MDM is January 1, 1992 (the time when the GPSs were initialized), not unlike a digital clock that defaults to 12:00 when first plugged in. Thus, the time in the C&C MDM needs to be reset. This can be accomplished in multiple ways. Most modern spacecraft use the GPS time, due to its accuracy. The GNC system has multiple antennae to receive the GPS signals for this purpose. Unfortunately, these signals can become interrupted or confused when, for example, some of the signal is reflected off parts of the ISS to the antenna. This can create the undesirable effect of causing the time value to jump around. The lower-tier MDMs, designed to gradually drift their own clocks to keep up with the C&C, cannot respond fast enough. When this happens, lower-tier computers can become unsynchronized with the CCS. Therefore, the ODIN/CRONUS flight controller monitors the CCS time and manually adjusts its oscillator to maintain GPS time.

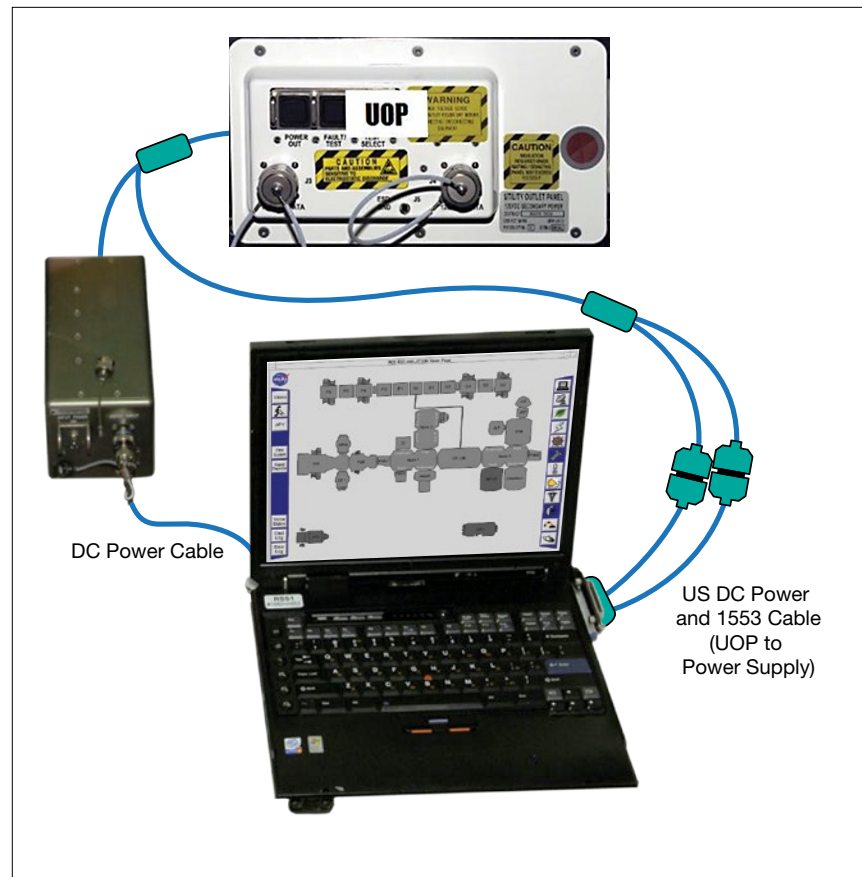
## Portable Computer System

The PCS is the crew’s interface with the station’s computer system. With the PCS connected to the C&C MDM via a special cable to a 1553 bus, as shown in Figure 3, the crew can send commands to the vehicle and receive the status of most systems. As many as eight PCS laptops can be connected at any given time. These laptops are distributed around the ISS in areas where the crew will be working.

The PCS is currently an IBM T61 laptop with a duo-core processor, which is in line with the goal of using as much commercial off-the-shelf

equipment as possible. The PCS has the same hardware, although not the critical software, as the crew’s SSC so that spares can be swapped back and forth easily, as needed. Basic parameters of the PCS are listed below. The PCS platform is the Scientific Linux operating system, based on UNIX, which uses a graphical windowing environment based on X-Windows. Both the PCS and the SSC can talk to a printer.

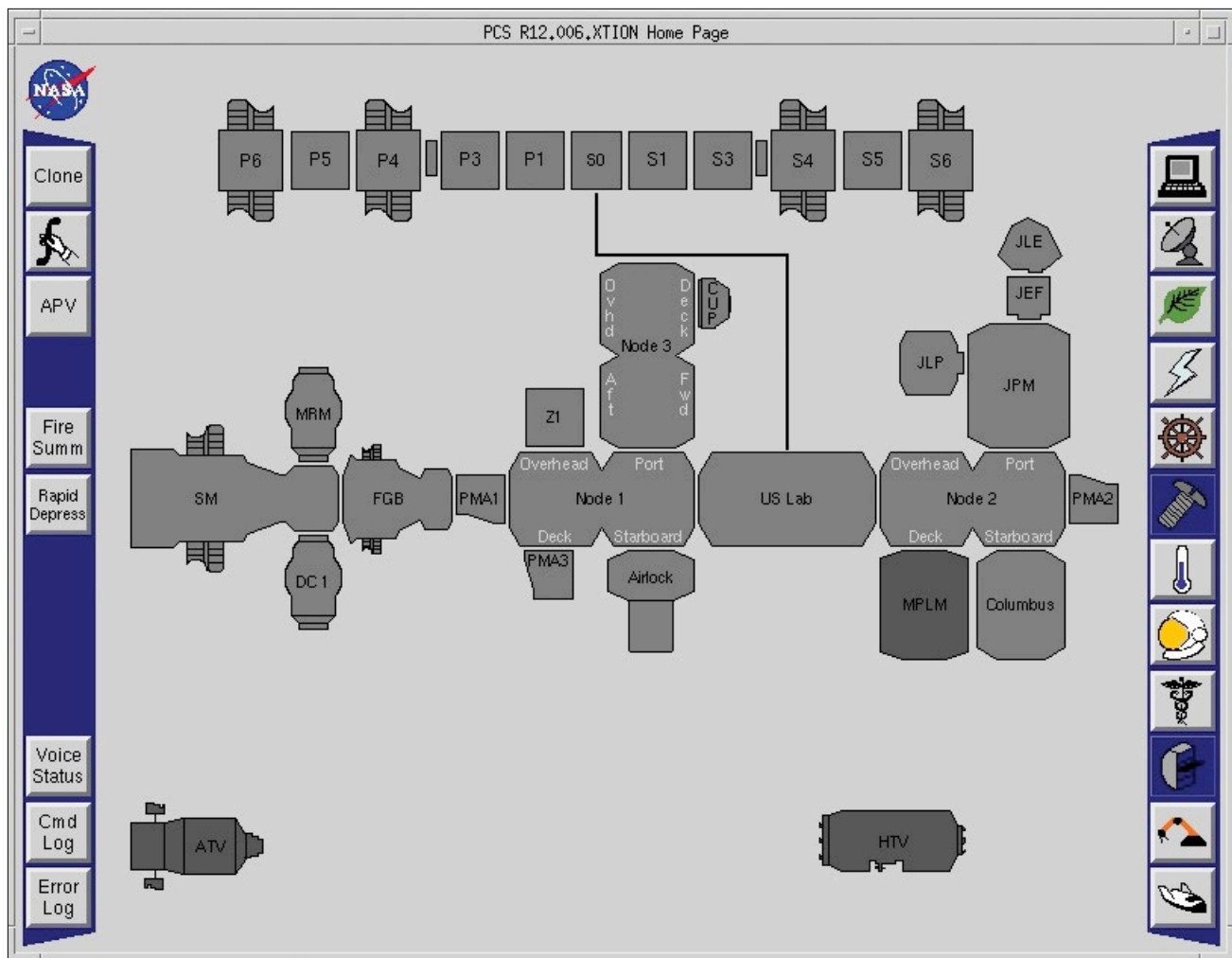
As the crew’s primary systems interface, the PCS needs to provide easy-to-use software that is intuitive to an astronaut of any nationality, especially during an emergency.



**Figure 3.** The PCS consists of a laptop with specially written software that plugs into a Utility Outlet Panel using a dedicated junction box that converts the station power to standard 120 V as well as a 1553 data cable. This panel provides electricity as well as a 1553 data connection to the CCS.

**Table 4.** Basic Parameters of the PCS

Features	Specification
Processor	2.5 GHz core duo
Memory	4 Gb RAM
Hard Drive	160 Gb
Battery	2.0-hour lithium ion battery
Display	39 cm (15.4 in) diagonal LCD display with active matrix 1920 x 1200 pixel resolution, 256 colors
Dimensions	4 cm x 36 cm x 2128 cm (1.4 in. x 14 in. x 11 in.), 2.7 kg (6 lb) with battery and DVD drive
External Power Supply	28 V DC or 120 V DC
Expansion Slot	Single slot for 1553 interface connector
Peripherals	DVD-RW/CD-RW
Pressure Range	456 mm Hg (9.0 psi) to 827 mm Hg (16.0 psi)



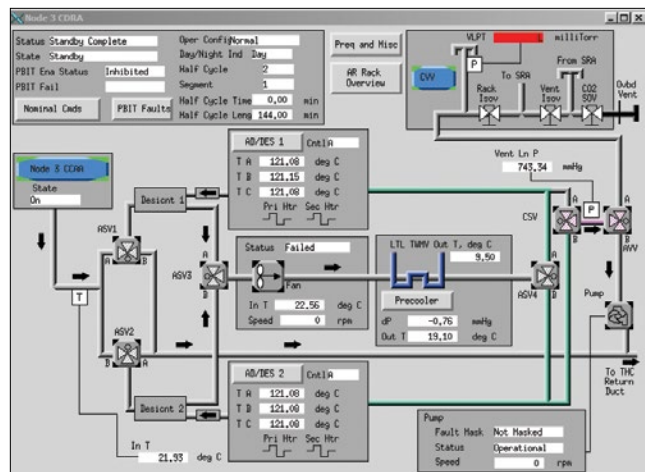
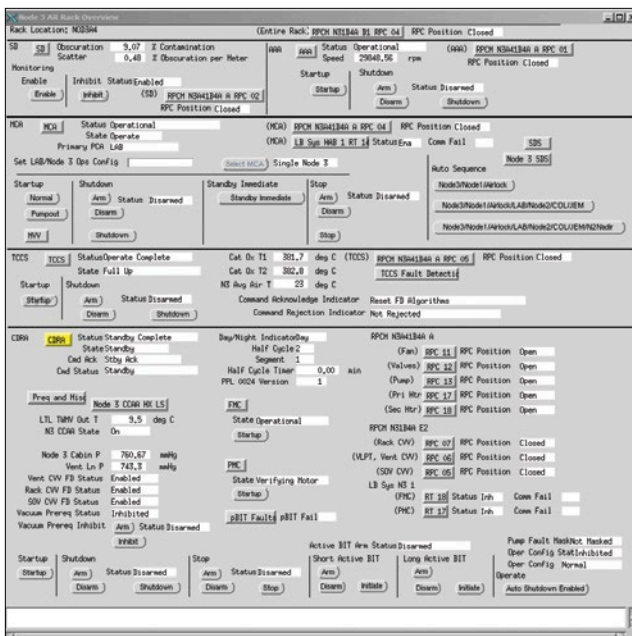
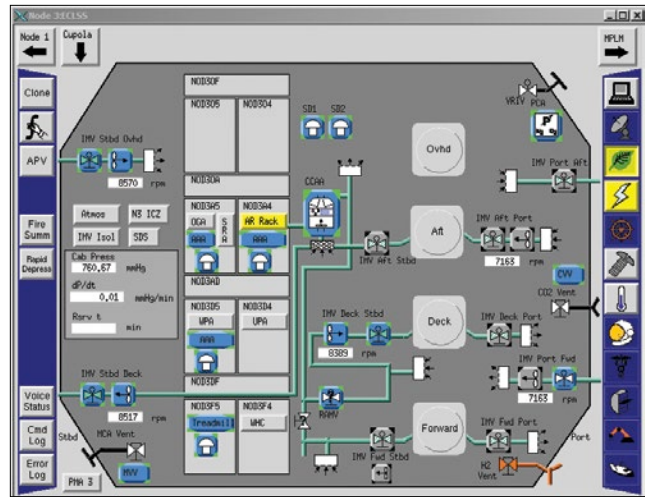
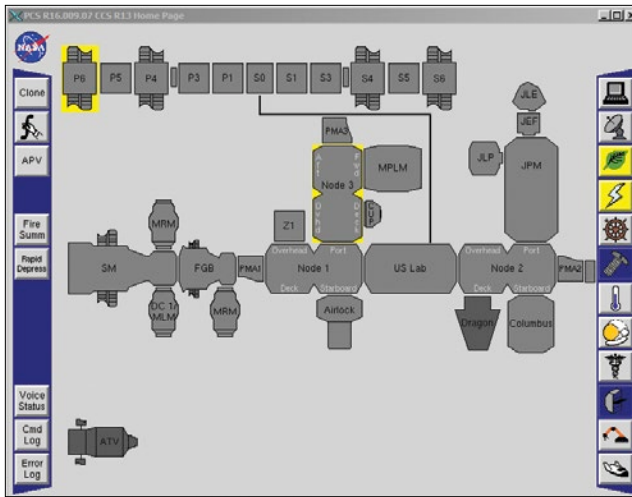
**Figure 4.** An image of the home page on the PCS. Each module of the ISS is represented. In addition, the astronauts can navigate to a specific system using one of the icons on the right side of the screen. From top to bottom: C&DH, communications and tracking, life support, power, attitude control, mechanical (not used), thermal control, extravehicular activity, medical, racks (not used), robotics, and emergency escape system (not currently used). Certain functions such as viewing the listing of commands (“Cmd Log”) issued by the laptop, a summary of fire or rapid depress status, or other miscellaneous tools can be accessed on the left side of the screen. Visiting vehicles such as the Automated Transfer Vehicle are also shown, when appropriate.



The home page Graphical User Interface (GUI) is shown in Figures 4 and 5. At a high level, the home page is a graphical representation of the ISS. Crew members can examine the status of all the systems in a specific module by clicking on the appropriate icon. Alternatively, the crew can examine all aspects of a particular subsystem by selecting the icons for

that system along the right side of the screen. Since the ISS is occupied by people from many different cultures, generic icons (e.g., a lightning bolt for the electrical system) are used as much as possible. The GUI graphics are integrated into the station's Caution and Warning (C&W) system. For example, a module is highlighted red or yellow if a subsystem in that

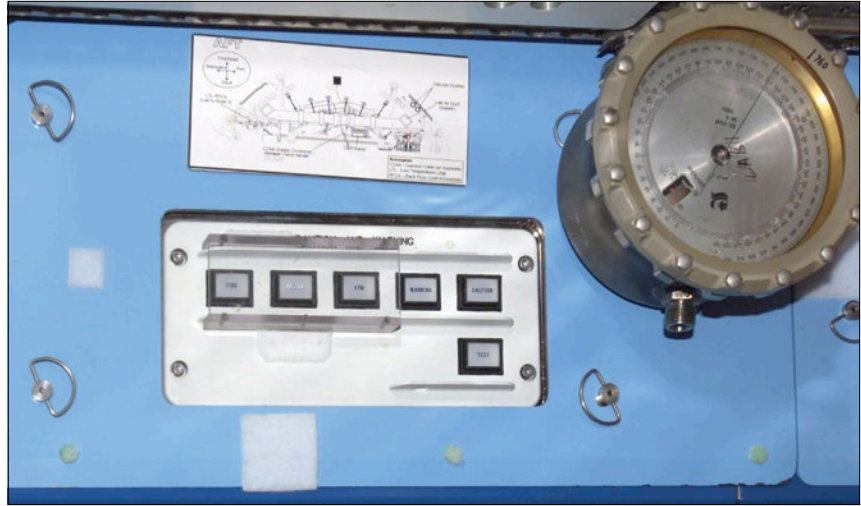
module is experiencing an alarm. Some emergencies, such as fire or toxic atmosphere, can result in the entire crew being isolated in the Russian Segment. A PCS is always maintained in that segment so that insight of the USOS is retained, even if the crew is temporarily cut off.



**Figure 5.** Alarm trace. The crew can use the PCS to zero in on the cause of an alarm. On the home page, a module will turn the color of the alarm class (top left). In this case, the electrical system and environmental systems in Node 3 and the P6 segments indicate an alarm. The crew selects the module that, in the example, shows a caution-level event in the Node 3 Environmental Control and Life Support System (top right). The control page for the rack shows (lower right) that the Carbon Dioxide Removal Assembly is in alarm. Selecting that module brings up a detailed page where the crew and ground can isolate the fault and perform further troubleshooting (bottom left).

## Caution and Warning

One of the most critical functions of the C&DH system is that of C&W. Alarms, or C&Ws, come in four classes. The most dangerous problems for a crew are fire, rapid depression of air, and toxicity in the atmosphere (i.e., from a leak in the ammonia cooling system, failed environmental equipment, or a spilled experiment). These are class 1 alarms (emergencies). Class 2 alarms (warnings) indicate that the crew or ground needs to take immediate action to avoid injury or death of the crew or damage to the ISS. Emergencies and warnings are indicated by red on displays. Class 3 alarms (cautions) are indicated by yellow and do not require immediate response by the crew or ground; however, if left uncorrected, such situations could develop into a warning-class event. The lowest level of alarms (advisories) indicate something is wrong that does not require immediate attention. These are more akin to the “check oil” light on a car. A special subset of advisories is the robotic advisories, which provide alerts for the robotic systems only. The number of alarms include approximately 80 emergencies, 800 warnings, 2300 cautions, and 6100 advisories. The majority of alarms indicate a failure of a redundant component, thereby posing no immediate threat. Failures are detected by an MDM in the chain and fed to the C&C MDM, which, in turn, determines the level of the alarm and routes it to audio speakers, light panels, and the PCS to alert the crew and ground. Most modules contain speaker systems for annunciating an audible alarm, much like a fire alarm in public buildings. Each class, except advisories, has a distinctive frequency to allow the crew to differentiate between alarms. Advisories do not produce an audible



**Figure 6.** The C&W panel. Each button will illuminate red or yellow as appropriate to indicate the presence of an alarm. The crew will push the button to either manually initiate an alarm, or to silence the tones. A glass cover protects against crew members accidentally bumping one of the emergency alarms.

EVENT#	ANNUN	CL	ACK	SYS	CSW MESSAGE TEXT	TIME OF ALARM
16466	ENA	U		MCS	Loss Of ISS Attitude Control	279/07:22:23
16143	SUP	C		MCS	GNC MDM Checkpoint Recovery Failed	279/07:22:23
11084	SUP	C		EPS	SARJ Stale Target Angle - P3	279/07:21:59
11062	SUP	C		EPS	SARJ Stale Target Angle - S3	279/07:21:58
11113	SUP	C		EPS	Stbd SARJ Alpha Angle Lost/Transition Blind Mode - S3	279/07:21:52
11127	SUP	C		EPS	Port SARJ Alpha Angle Lost/Transition Blind Mode - P3	279/07:21:52
5014	SUP	C		CDH	Primary GNC MDM Fail-LAB	279/07:20:56
16928	SUP	C		CDH	ATS - Last ATS SHD Event Detected	UNKNOWN

EVENT#	ANNUN	CL	ACK	SYS	ADVISORIES MESSAGE TEXT	TIME OF ALARM
1045	ENA	A		EPS	PVDU 2B Beta Angle Lost Ancillary Data-P6	279/07:21:14
1796	ENA	A		EPS	PVDU 4A Beta Angle Lost Ancillary Data-P4	279/07:21:14
2312	ENA	A		EPS	PVDU 3A Beta Angle Lost Ancillary Data-S4	279/07:21:14
11986	ENA	A		EPS	PVDU 1B Beta Angle Lost Ancillary Data-S6	279/07:21:14

EVENT#	STAT	ANNUN	CL	ACK	SYS	EVENT MESSAGE TEXT	TIME OF EVENT
16466	ALARM	ENA	U		MCS	Loss Of ISS Attitude Control	279/07:22:23
16143	ALARM	SUP	C		MCS	GNC MDM Checkpoint Recovery Failed	279/07:22:23
6826	NORM	ENA	A		CDH	Primary CC MDM Detect Loss of Comm with GNC 2 M...	279/07:22:16
11084	ALARM	SUP	C		EPS	SARJ Stale Target Angle - P3	279/07:21:59
11062	ALARM	SUP	C		EPS	SARJ Stale Target Angle - S3	279/07:21:58
11113	ALARM	SUP	C		EPS	Stbd SARJ Alpha Angle Lost/Transition Blind Mod...	279/07:21:52
11127	ALARM	SUP	C		EPS	Port SARJ Alpha Angle Lost/Transition Blind Mod...	279/07:21:52
16151	NORM	ENA	A		MCS	GNC MDM Checkpoint Failed Restore Cycle	279/07:21:24

**Figure 7.** The C&W Summary used by the crew and flight control team in mission control. Events that are actively in alarm are indicated with yellow or red, depending on the class. Less-critical advisories are shown in white. Text describing the alarm is shown in the middle, followed by the time the alarm annunciated (in Greenwich Mean Time). The bottom displays a log of events and history (e.g., in alarm, normal).

like a fire alarm in public buildings. Each class, except advisories, has a distinctive frequency to allow the crew to differentiate between alarms. Advisories do not produce an audible

alarm. Distinctive frequencies are required because one anomaly (e.g., a fire) could produce multiple class failures and the crew needs to know quickly which is the most critical.

Many modules possess C&W panels with colored lights that indicate an alarm is present (Figure 6). Pushing a button on the C&W panel will silence the alarm tones until another failure occurs. Crew members can manually initiate an alarm by pushing an alarm button on the panel if, for example, they detect something such as smoke that the automated systems failed to detect. Each alarm also has an associated detailed text message that is displayed in the C&W Summary. This text message explains, in English, the nature of the failure (Figure 7). Generally, the ground will try to work most events unless a long period without communications (either scheduled or unplanned due to a failure) is anticipated.

If an individual alarm becomes a nuisance, it can be “inhibited” to prevent disturbing the crew unnecessarily. In this case, the system completely ignores the alarm and no one, not even the ground, is alerted. An example might be the water level of a condensation tank. If the level is oscillating right above and below a critical level, the alarm might be triggered repeatedly. If it is deemed noncritical and the ground can monitor the level closely, the alarm is then inhibited. The audio alarm also could be suppressed when the crew might need to be alerted to an alarm eventually but not immediately. In this case, the lights would still illuminate and the message would be present on the PCS, but no alarm tone would be issued. Thus, the crew and ground could monitor the situation without being deafened by the loud tones. This is especially useful during crew sleep periods.

## Software

The software executing in each MDM, the User Application Software, is unique to the function of that particular MDM. For example, the software executing in the GNC MDM contains routines that are needed for attitude control and navigation. Different software runs in the External MDM, which is mainly concerned with controlling the solar arrays and the External Thermal Control Systems. Utilities such as communicating on the bus are common between all the MDMs (although with a few minor deviations developed across the different systems). Different segments of Boeing, the prime ISS contractor, produced different software systems. All combined, the ISS C&DH system consists of approximately 1.8 million lines of computer code.

Sometimes, software needs to be changed. This can be accomplished in two different ways on the ISS. First is through the use of a Pre-Positioned Load (PPL). A PPL is a file of data parameters or commands that can be uplinked by the flight controllers at any time to change specific values. For example, a critical PPL is the one that controls load sheds. A load shed occurs if the Electrical Power System cannot produce enough electricity. This could happen if the guidance system failed and the ISS was no longer able to point the solar arrays at the sun. If a load shed is triggered, the PPL will execute the commands inside of it to power off the least-critical equipment first and then pause. If the power problem is more severe, the flight control team or the

automatic software will resume the execution by the PPL, thus powering off additional equipment. This list of equipment also changes as the station changes (e.g., if modules are added or moved); therefore, the PPL is periodically updated. Alternatively, the temperature at which a heater turns on or off might need to change, just like adjusting the thermostat in a house. Rather than change the software code, the software looks at a particular value defined in the PPL. If this needs to be changed for whatever reason—say, from 18°C (64°F) to 15°C (59°F)—a new value is set in that particular PPL. The software itself can also be updated. This is discussed further in Chapter 6.

Another critical function of the C&DH system is to recover the function lost when a failure occurs. This software is generally referred to as Failure Detection, Isolation, and Recovery. The software will first detect the failure of a component and announce a C&W message, depending on the severity. Many key ORUs on the ISS have what is called a heartbeat—basically, software that is constantly counting up. If this number is changing, the ORU is alive. A static heartbeat means the ORU is no longer healthy. Many systems that die will also lose computer communications with the MDM. Isolation refers to the software taking an action to put the system into a safe configuration. For example, if a valve is stuck closed in the cooling system, the pump can be damaged by trying to push fluid against it. This is called dead heading. The isolation software will turn off this pump. Recovery means that a backup system, if available, would be turned on.

A special case occurs when an MDM fails. Among the MDMs, the C&C performs the recovery of the Tier 2 MDMs since they are redundant. Upon detecting a loss of communication with a Tier 2 MDM, the C&C will power on the Backup (normally kept off to minimize wear and tear) and command it operational. This process is called Redundancy Management (RM). A serious scenario, such as a major power channel failure, can cause multiple components, including MDMs, to be powered off. The CCS will perform RM on each Tier 2 MDM that failed, beginning with the most critical MDM. As the Tier 2 MDMs are recovered, they will detect any problems in their systems and will execute automated software to reconfigure their system, including bringing online redundant equipment. For example, the same power channel failure that powered off an active INT MDM could have left half the pumps for the internal cooling system unpowered in the Laboratory Module. The newly recovered INT MDM will detect one pump as off (“failed”) and reconfigure the water loops so that the remaining pump is cooling the entire system. Flight controllers will then do any further cleanup of the less-critical systems. Critical equipment, including MDMs, are usually put on different channels to minimize such impacts from the failure of a single power or cooling channel. Thus, if C&C-1 MDM is the Primary MDM, the INT-2 MDM on a different power channel may be configured as the Primary for that pair so that an issue with the power system is unlikely to power off both at the same time.

Another key function of the software relates to what are called modes. The ISS is a large, complicated system.

When the vehicle is reconfigured for key activities—e.g, preparing for the docking of a visiting vehicle—a lot of systems have to be changed to support the new mode or configuration. Mode transitions are automated to help relieve the work of the ground team. When the ISS is supporting regular increment operations, it is in Standard mode. The ISS transitions to Proximity Operations mode for visiting vehicle dockings. When the command is given, the C&C MDM will fire off a large number of commands to all the systems to configure the systems appropriately. Other modes include Microgravity, Reboost (for raising the station altitude), and External Operations (intended to be used for extravehicular activities). A Survival mode attempts to maintain the minimum systems required to keep the crew alive.

## **Assembling the Command and Data Handling System**

Assembling the C&DH system was relatively straightforward, unlike several other systems described elsewhere in this book. Adding a computer to the network on the ISS is not all that different from adding a computer on a home or work network—with one notable exception. Prior to ISS-5A, the only USOS MDMs were the Node MDMs and the P6 PhotoVoltaic Control Unit (PVCU) MDMs. The crew would interface with the Node Control Software using the early PCS. At 5A, a number of MDMs were added and the PCS became the permanent method for crew interaction with the C&DH system. Transitioning from Node software to CCS control at 5A was the biggest expected challenge

for the ODIN team during the ISS assembly process.

The Node Control System (NCS) assumed interim C&C upon power-up in 1998 of the first element of the USOS—Node 1. The NCS controlled some fans and connected to the Early Communication System, which was used for talking to the crew and getting status telemetry on the ground. Later, at 4A, the Node MDMs worked with the PVCU computers on the P6 module to provide power. The Laboratory Module, launched in 2001, contained the CCS, which was destined to be the Tier 1 C&C as well as the INT, EXT, and GNC MDMs. The challenge is that the station cannot be without a Tier 1 computer for extended periods of time, and there can be only one Tier 1 controller at a time. Therefore, a careful handover from NCS to CCS had to be developed. Fortunately, a function designed to recover the C&C MDMs in the event of a failure provided a clever mechanism to achieve this.

The NCS is technically a Tier 2 system under the CCS. Early on, it was realized that, in the unlikely event of all three C&C MDMs failing, there needed to be a way to power cycle them in the hope of recovering them (much as a desktop or laptop can be recovered if a software lockup occurs). If that effort was not successful, there needed to be a way to assume control of the ISS. If all three C&C MDMs were to fail, the NCS would detect the absence of a BC and begin power cycling the C&C MDMs. The NCS would then give up the bus control to allow the CCS to boot up and take charge. If, after a certain amount of time, the NCS still detected no BC, it would go back to controlling the main busses until the

flight controllers reconfigured the system. Although the NCS cannot really communicate with the INT, EXT, or GNC MDMs, it would still provide the crew with at least a small amount of insight and control. Since the Node MDMs were the “little guys” compared to the “big” C&Cs, this software process was dubbed Mighty Mouse, based on the old American television and film cartoon.

Activating the Laboratory Module—the brains of the USOS—at 5A was a bit of a chicken-and-egg dilemma. Computers were needed to operate the systems, but they generated heat as did the other systems coming online. Therefore, the Thermal Control System needed to be activated as soon as possible to provide cooling to the computers already activated before they overheated. The Thermal Control System, of course, needed computers to operate. A variation of Mighty Mouse software was used to affect the handover of control from the Node to the laboratory during STS-98/ISS-5A. The successive waves of power cycling various C&C MDMs, followed by waiting for signs of life, were stripped out in the software to save time on the assumption that the C&C-1 MDM would not be failed at the start of its life on orbit. Instead, the NCS would power on C&C-1, relinquish control of the busses, and wait to either detect the CCS or resume control if unsuccessful. This software was now dubbed Minnie Mouse, based on the Disney character and building on the mouse theme. Upon transitioning to its normal Operational mode, the CCS would see no INT MDM, thus triggering RM to initialize the INT MDM. During the mission, the astronauts would command the Node computers into Minnie Mouse mode.

The flight controllers and astronauts would hold their breath for 5 minutes. If it worked, automated software would begin configuring the rest of the systems. If it didn’t work, the ISS could be left in some limbo state with no computer in charge. Fortunately, everything executed flawlessly.

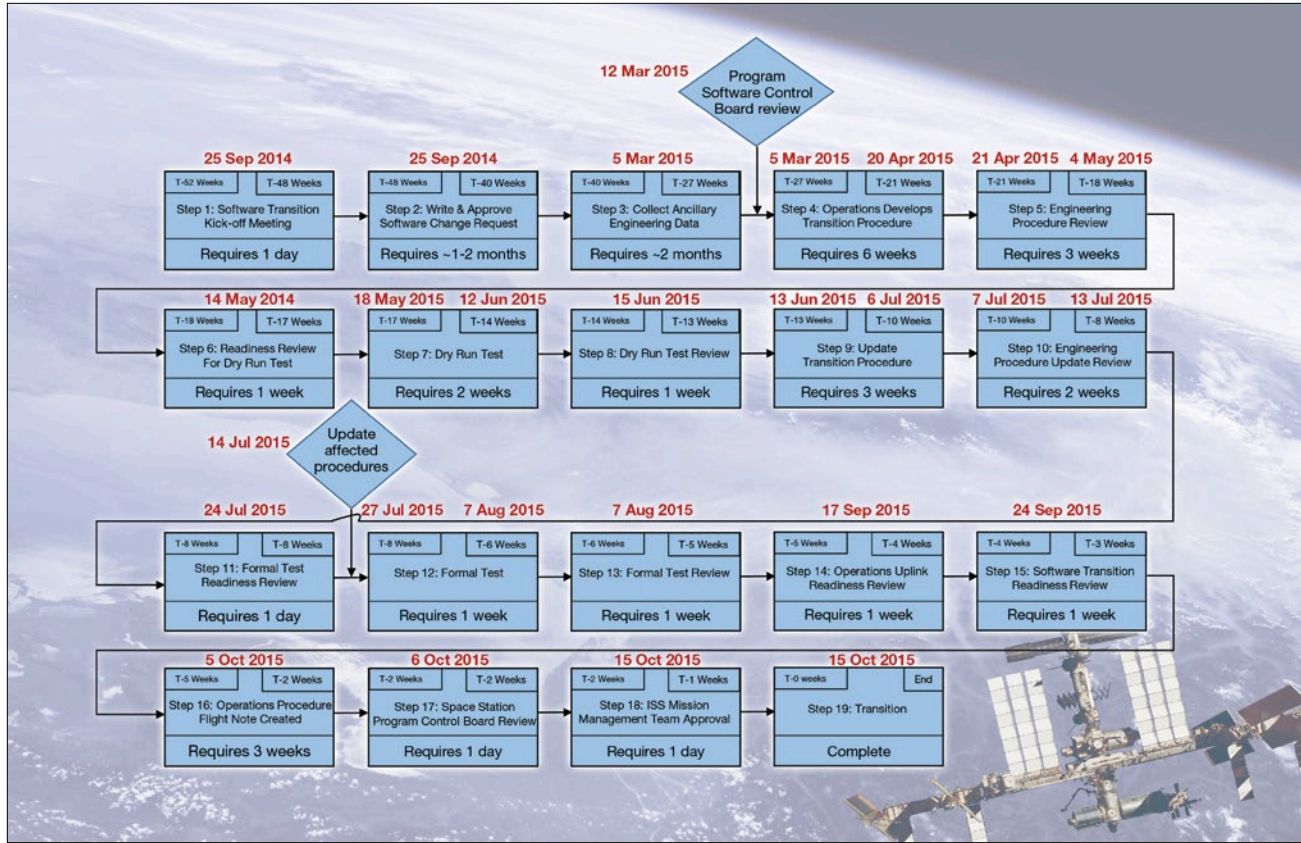
The new MDMs were integrated relatively seamlessly as new modules were added to the ISS. Upon activation of the module, the new Tier 2 or Tier 3 computers would immediately transition to an operational mode and begin talking to the next-higher level. From about 2000 to 2014, the C&DH system grew from two MDMs to 46. Major software upgrades have occurred about once per year (see also Chapter 6).

## Conclusion

Unlike previous manned spacecraft, the ISS is almost completely controlled by computers. The computer system runs every spacecraft function from controlling the solar arrays to keeping the power generation going to communication with the ground. It also reconfigures other computers and hardware in the event of a problem. These failures are announced to the crew and ground through various cautions and warning with lights and audible tones. While the flight controllers on the ground communicate through the ISS via the C&C MDMs, the crew interface with a laptop called the PCS. Finally, as with the ISS itself, the C&DH system has evolved over the years, most notably by upgrades to the software and sometimes the hardware, as is the case with terrestrial computers.



Chapter 6 Day in the Life:  
“Brain Transplants”  
on the International  
Space Station



Flowchart showing the 1-year process required to plan and execute a software upgrade to the major systems on the International Space Station. Each block represents a milestone. The upper-left box indicates how far in advance of the transition (T) the activity should start. The upper-right box indicates when the activities should be complete. In this example, the actual completion dates for the Release 14 update (described below) are indicated in red above each box.

**Terrestrial computers need to be periodically updated to accommodate new features, fix bugs, or address compatibility issues as other systems evolve over time.** Software on the International Space Station (ISS) is no different in that way. Where the software on the ISS does differ is that every vital function of the space station is controlled by a computer and cannot be suspended while software is changed. Critical ISS systems cannot afford to simply wait while updates are applied and computers are rebooted. The two main reasons for updating space station software are to install upgrades for new features and

to fix problems. The development of the software was staggered over time, particularly over the ever-changing configuration of the ISS during its construction. There was no point in having software that performed a function—say, controlling a cooling loop or module—when that loop or module was to be installed years down the road. It takes years to design the code to control the space station, and additional years to write and test the software before it is installed. Furthermore, errors can arise from a simple typo when the code was written. Rigorous testing catches the vast majority of these problems. Other errors come from how the coders

interpreted a software requirement, or are due to evolution of the team’s thinking as the system matured. If an error is critical, the code will be updated before it is loaded on the space station computers. The update to fix bugs that have a noncritical impact or that the flight team can work around may be made in a subsequent release so as to not impact the schedule. Considerable care in terms of testing, planning, and execution is taken when ISS computers are updated. If done properly, the crew hardly notices any changes.

The ISS software was first upgraded in October 2002. At the time, it was the largest software upgrade ever



performed in space. The process took about a year to plan and execute. Since then, similar software upgrades have become “routine,” having been performed more than a dozen times since. To reduce cost and assist with scheduling, large-scale ISS software upgrades are now planned to take place once a year. The entire process of identifying changes, developing and testing code, and planning and executing the transition is ongoing. Once a change has been approved and implemented in the code, it is included in the next scheduled upgrade.

The ISS hosts three types of computers (see Chapter 5). All critical ISS functions are controlled by the Multiplexer/DeMultiplexers (MDMs). The MDMs, and the Portable Computer System (PCS) that controls them, were designed for regular updates. This chapter discusses how the operations team prepares for and executes this critical task. The crew’s Station Support Computers are upgraded similarly to laptops on Earth and are not discussed here.

Major upgrades are scheduled about once a year due to the complexity of the software controlling the ISS. It takes many months of planning and training to accomplish a software upgrade. This schedule allows careful development of the transition. In many ways, a software transition is just as complicated as the execution of a spacewalk or the docking of a new vehicle. The flight director and his or her team work closely throughout the year to prepare for the upgrade. This chapter describes the process of updating the software: changing the code, developing the complicated plan for installing it, testing the plan, executing the plan, and recovering from problems during the upgrade, as sometimes happens.

## The Life Cycle of Code

During the design phase of the ISS, engineers determined which functions the software needed to control. For example, consider the operation of the massive solar arrays, which generate the critical power needed to run the space station. The arrays can articulate at the Solar Alpha Rotary Joint and the Beta Gimbal Assembly (see Chapter 9) to ensure they are always pointed in the direction of the sun. Software tells the arrays where the sun is positioned, and the motion of the ISS as it orbits the Earth. Thus, the arrays will slowly move throughout the orbit to maximize power generation. The arrays are parked and locked in a position during the arrival of docking vehicles to minimize thruster loading on the delicate surfaces of the arrays. The software needs to know how to move the panels to the required position and then use the gears to lock them in a fixed position. Software will respond if, for some reason, the gears have a problem and cannot lock properly (similar to the way a car’s transmission gears crash instead of mesh smoothly). If the power controlling these motors is lost, software will use alternate power or motors to complete the critical task. This is just one example of how engineers will define all the needed software functions and then write detailed requirements to describe how each function will operate. Flight controllers play a part in developing these requirements since they are the ones who will be operating the software that is on the ISS.

Software engineers then take the requirements and generate the code. The logic of the code is carefully reviewed with other programmers

to ensure it does what is intended. During this phase, the flight control team works closely with the programmers to understand and influence the design. During the assembly of the ISS, the flight controllers were extremely involved in the development of the vehicle software. Once completed, the software undergoes various levels of testing to ensure that it correctly meets the requirements and interfaces with other software code properly. Testing culminates with a flight qualification test where the software is put through its paces under realistic situations.

In a perfect world, a complete second space station would exist on the ground to run the software to ensure it works correctly; however, such an approach is cost prohibitive. Instead, testing is done on a combination of flight-like items and simulation or emulations. A flight-like unit may be an exact copy of a unit flown on the space station, or it might be a flight equivalent unit—something very close to the real hardware but with cheaper parts that replicate the behavior of the real unit. A simulator or emulator is essentially a software program that will react the same as the real system. For example, software controls the pump speed in the Thermal Control System loop, perhaps increasing water flow if more cooling is needed (see Chapter 11). The simulation will reveal the temperature to the MDM. The MDM will send a command back to the simulation, telling it to increase the pump speed. The revised pump speed and the resulting cooler water temperature are echoed back to the MDM. In this way, the control software inside the MDM is executed

without requiring an actual Thermal Control System to be connected.

Note that this sort of testing has to be integrated with all the systems. The Command and Control System (CCS) software interfaces with the Internal, External, and Guidance, Navigation, and Control (GNC) software, to name a few, as well as the Russian, European, Japanese, and commercial partner systems. Code changes in the CCS have to be tested with the latest code in all these systems to ensure compatibility. Testing between the CCS and the Russian computers is some of the most complicated owing to the critical functions that both segments control, and because the systems are very different. This is called “four-box testing” since it uses flight-like items for the four key computers (Command and Control [C&C] MDM, GNC MDM, Service Module Central Computer, and the Service Module Terminal Computer) on both sides of the interface. Flight controllers and engineers from multiple countries spend months testing the four-box configuration.

Once the software has passed the flight qualification test, it is ready to be loaded on the space station computers.

## Preparing for the Transition

Once the software is ready for uplink, the operations team—consisting of the key personnel from the various disciplines along with the flight director—begins the process of preparing for the actual installation. As with a Space Shuttle mission (see Chapter 4) or a spacewalk (see Chapter 17), a lead team is assigned to the project. The process of a software upgrade is fairly complicated. The first thing the team needs is to figure out is the strategy—i.e., which computers are to be updated and in which order. Changes to the CCS will affect other Tier 2 computers as well as the crew’s PCS and perhaps the robotics software. Therefore, changes to those computers are usually updated around the same time. For example, the 14th release of the CCS, called Release 14 (R14), was combined with seven other operating systems on 11 MDMs and PCS laptops. Although several computers are being upgraded, by convention the entire set of transitions is labeled according to the CCS software being uploaded. The upgrade is summarized in Table 1 and represents updates to nearly 1.5 million lines of software code.

The transition to the new software has to be seamless since the software is still controlling the vital functions of the space station. Therefore, the new software is loaded to the backup computer for those systems that have a backup. The primary and backup computers are swapped when the team is ready, during a time in which there are no major activities such as a visiting vehicle docking or a spacewalk. Usually, this is accomplished by telling the primary to mode itself to a standby or diagnostic safe state (see Chapter 5). Seeing no primary, the backup MDM will transition to that role, but will be operating on the new software. If a backup MDM does not exist, as is the case with the Tier 3 MDMs (see Chapter 5), the sole computer is loaded in a diagnostic state and then transitioned to operational when ready.

Whenever the CCS is upgraded, the PCS software is also upgraded since both work hand in hand. Unlike the MDMs, this can be done via CD-ROM (as can be done via laptop on Earth) or by sending up a new hard drive with the software already loaded. Half the PCS laptops are converted to the new software prior to the transition. Only half are loaded to allow for a possible

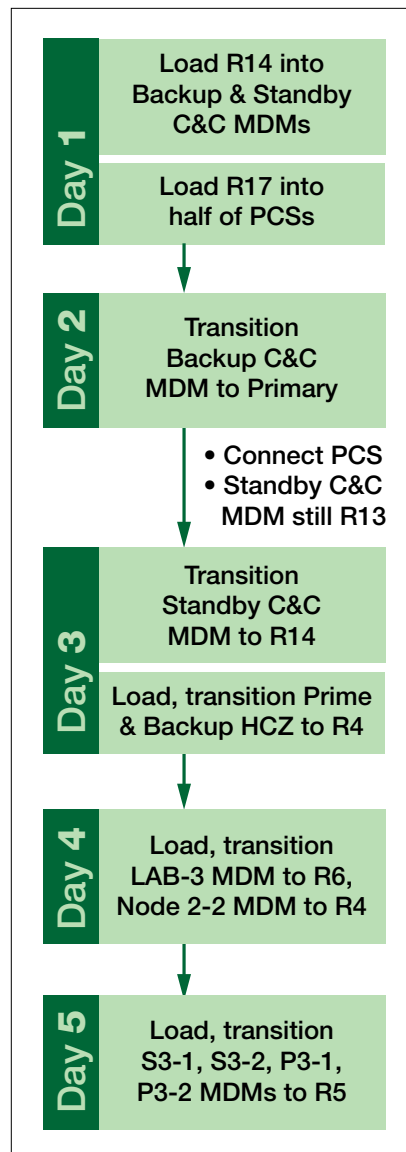
**Table 1.** Summary of software systems upgraded in the R14 group transition. See Chapter 5 for more details on the different MDMs and software systems. This is the software transition shown in the flowchart at the beginning of this chapter.

Software System Old Release → New Release	Number of and Computers Affected
Command and Control Software (CCS) Release (R)13 → CCS R14	3 – Command and Control Multiplexer/DeMultiplexers (MDMs)
Portable Computer System (PCS) R16 → PCS R17	7 – PCSs
Mobile Servicer System (MSS) 8.1 → MSS 8.2	3 – C&C MDMs
Hub Control Software (HCS) R3 → HCS R4	2 – Hub Control Zone MDMs
Starboard 3 (S3) Port 3 (P3) R4 → S3P3 R5	4 – S3 and P3 MDMs
Laboratory System 3 R5 → LSYS3 R6	1 – LA-3 MDM
Node 2 System (N2SYS)2 R3 → N2SYS2 R4	1 – N2-2 MDM

“rollback” to the old configuration if a problem is encountered.

Generally, the C&C MDMs are swapped to invoke the new software. The crew connects the upgraded PCS laptops that are loaded with that software. The ground evaluates data to ensure everything is operating properly. If all is as it should be, the next pair of MDMs is swapped—usually the Internal MDM, followed by other pairs. The computers with the old software are not immediately reloaded. An extensive amount of testing is performed before the computers on orbit are reloaded; however, there is always a chance that something is missed within the simulated environment, which is not 100% identical to the real vehicle. Therefore, the operations team typically waits about day to make sure everything is working properly. If everything works, the computers with the remaining old software are reloaded and that portion of the transition is completed. If not, the old software can be rolled back quickly by swapping it with the computer that is still running the old software. The team then determines the best configuration for the software until the issue can be resolved. The real-time timeline for the R14 load is shown in Figure 1.

Flight controllers, under the direction of the flight director and working with the engineers, figure out the transition plan, which is then reviewed by the engineering team. For example, do the systems need to be put in a certain configuration prior to the transition? Which operations must be stopped during the transition and which can safely continue? Once the plan is worked out, the procedures are



**Figure 1.** Graphic illustrates the day-by-day process over 5 days of loading all the computers for the R14, as defined in Table 1. Each block represents a set of activities performed on a given day. Each step-up is done in small steps to allow for time to assess how the software is working. If everything was transitioned at once, it might be hard to identify a problem.

written, including some for likely contingency scenarios. At that point, the procedures are operationally tested. In these tests, the flight

control team in Mission Control executes the procedures with the ISS Software Development and Integration Laboratory in what are called flight-like operations readiness tests. These tests include configuring the simulated systems into a known ISS-like state for the actual swap, sending all the new code to the computers, executing the switchover, and reconfiguring all equipment back to the normal operating setup. Multiple tests are performed to ensure everything is properly evaluated. Once any issues are worked out, a test that uses a flight-like mission configuration is performed.

Note that this describes only the process to develop the transition procedure. New software means new operations of generic procedures, and possibly new flight rules. Therefore, the transition team will also lead the development of all the procedure updates—typically on the order of 150 updates. Each procedure has to be revised and tested in an operations readiness test. The flight director oversees the flight rule modifications.

## Planning the Transition

Once the uplink procedure has been developed and tested, it is ready for the transition. The increment team tries to find a time to perform the upgrade (see Chapter 1) while the testing is taking place. In an ideal world, the software is ready at a given time and the team performs the uplink. In the dynamic world of the ISS, this is rarely the case. For example, visiting vehicle software needs to be tested with the version of the ISS software that will be

operating during that vehicle’s mission to the ISS. However, both the visiting vehicle and the software transition schedules are often very dynamic. If a visiting vehicle mission was to overlap a software transition, its software would need to be tested with both versions of ISS software. Flexibility could be provided by testing all permutations of software interaction. However,

the required testing is time consuming and expensive, thus a lot of effort is put into scheduling software transitions away from visiting vehicle and other dynamic operations. To date, this has not been anything more than a planning exercise. Therefore, careful evaluation of impacts to the software schedule are required when a mission does change its schedule.

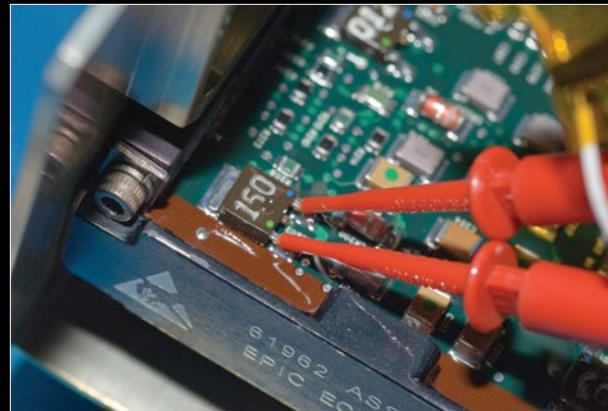
Several program reviews are scheduled as the time approaches to ensure everything is ready for the transition. As with other major activities, the flight director will brief the program management on the proposed changes and plan, with the final “go/no go” occurring at the ISS Mission Management Team level a few days before the planned event. Here, the program

## “EPIC or BUST”

### *Don Pettit, Expedition 30 and 31*

An orbital “brain transplant” can be done with new software uplinked into the flight computers via radio waves. As in a B-grade sci-fi movie where some hapless creature’s brain is reprogrammed, the old system is replaced with the new—usually, but not always, with known results. This is accomplished from Mission Control. If the brain transplant goes as designed, the on-orbit crew may not even know it happened.

Sometimes, the necessary upgrade actually requires new brains. This happened during my last visit to the space station in 2012 during Expedition 30. The central processing units for the main computers were being upgraded from the 8086/16 MHz processors that were launched with new Pentium 266/144 MHz chips (Chapter 5). These new brains, known as Enhanced Processor and Integrated Communication Controller, or EPIC, cards, were required to handle the more advanced software before the visiting cargo spacecraft could approach and berth to the United States On-orbit Segment—events planned for the very first time about a month into our mission. No pressure on us, except that the fate of the commercial space program hinged on our ability to perform this brain transplant. My commander Dan Burbank and I received hours of preflight training, prying the old computer boards from the MDM out from practice flight computers and replacing them with shiny new ones, complete with gold-plated contacts and conformal-coated circuits. The conformal coating is a



**Figure 2.** Astronaut Don Pettit uses the oscilloscope to measure the EPIC cards’ timing signals.

polymeric film that keeps aimlessly floating bits—i.e., little chunks of zero-gravity detritus—from shorting out the circuit boards. All the brain transplants were planned early in our mission so that the first commercial spacecraft, Space Exploration Technologies Corporation (SpaceX) Dragon D1, could pay us a visit. The new brains, all 10 of them, were already on orbit well before my launch. We were all set for brain surgery. Or so we thought.

Then we found out the new processor cards (already on orbit) were built at the factory with a defective component that would cause the internal clock timing to go bonkers, thus causing the computer to do the orbital equivalent of the “blue screen of death.” It is not good for spacecraft brains to go into la-la land when you are traveling at 28,163 km/h (17,500 mph) with a commercial spacecraft waiting on your doorstep (Chapter 14). To complicate

manager, international partners, and operations team review the status of the transition to make sure everyone is ready to begin the process.

## Loading the New Software

The process of loading new software is time consuming. Since the MDMs do not have CD-ROM readers, all

the software has to be uplinked. The software is large—representing about 30 MB of data in hundreds of files. Since the S-band link with the ISS (see Chapter 13) can transmit about 72 kbps, it takes about 30 hours to uplink the files to the computers. At the same time, the crew will spend a couple of hours configuring several of the PCS laptops for the new CCS software.

Once all the software has been staged on board, the team executes the planned transition. Due to the need to reconfigure ISS systems, the transition will usually take multiple days with one or two MDMs being loaded each day. The ISS crew is kept informed of the progress of the transition, as specific versions of procedure may need to be run depending on which software version

matters, this defective chip was estimated to be in only one out of the 10 circuit boards. We were playing orbital roulette. Only two or three spare circuit boards were in existence (still on Earth), and they fortunately checked out. These were manifested to launch with me on Soyuz. But how would we beat the odds of this game of orbital chance? The answer came from the orbital repair and maintenance team, passionately called Operations Support Office, or OSO, working closely with Honeywell, which had manufactured the cards. They found a small electronic widget that converts a laptop computer via the Universal Serial Bus port into a fully featured oscilloscope. The part was actually a Link Instruments' MSO-19 Oscilloscope, Logic Analyzer, Pattern Generator and Time Domain Reflectometer. As I said, a widget. With this device, it would be possible to power up the circuit boards on orbit and run them for a few hours where errant timing would become obvious. We now had a way to find the "bad boy." All we had to do was stow this on my Soyuz. Or so we thought.

By the time the Mission Control team had this worked out, I was in Baikonur, Kazakhstan, literally halfway around the world from Houston. And I was only days away from launch. To officially have this manifested and tucked away into some tiny nook on the Soyuz was not deemed possible. Some things, seemingly simple, find unbelievable friction when they cause a change in the matrix.

Each crew member has an allotment of 1.5 kg (3.3 lbs) of personal items, little knickknacks that help remind them of family and friends over the 6 months they are orbiting Earth. These items are painstakingly weighed

on an electronic scale with no allowance for being overweight. I offered some of my personal mass so that the oscilloscope could fly; however, the flight unit was still in Houston. NASA worked to expedite the transfer of the flight unit from Houston to Moscow and from Moscow to Baikonur. Within days, the flight unit arrived in my dorm room. I even practiced measuring the signal from the coffee pot in my room. Our team's mantra for this project was "EPIC or BUST."

My personal allotment was already full, so I started pulling items off the scale until it reached the acceptable mark. My wife's necklace, gone. My twin boys' camping spoons, gone. My alma mater's pennant, gone. Mission patches for family and friends, gone. The scale tipped to the good side and I was set to launch.

Dan Burbank was already on orbit, having launched the month before. I launched on December 21, 2011, the same day that comet Lovejoy surprised astronomers when it emerged from behind the sun with a brilliant tail. We unloaded the cards and widget the next day and started in on neural surgery. Dan did the surgery, replacing old brains for new. I set up the oscilloscope and checked out the circuit boards that were already on orbit. Working with all the folks in Mission Control, it took us a week or so to complete the brain transplant. This is teamwork at its best. Nine days later, we loaded the new software ("R11") on the repaired computers. The new hardware, coupled with the new software, worked as designed. In May, I flew the Canada robotic arm and snagged Dragon D1, thus ushering in the world of commercial space.

is currently operating. After the software has been loaded, the team archives any products associated with the previous version of software and performs a lessons-learned review to identify any improvements to the process for the next transition.

## Lessons Learned

Over the years of operating the ISS, many of the lessons learned have helped craft more-efficient software transitions and corrected items that caused issues in earlier transitions.

An early example of this came during the first major CCS transition. The operations team is responsible for developing certain configuration files for the MDMs. In this case, NASA developed a Load Shed Table—i.e., a list of commands used to deactivate electrical loads in off-nominal situations for CCS R1. When the planning process started for CCS R2, it was determined that the commands listed in the Load Shed Table did not need to be updated at that time. A default Load Shed Table built by software developers was used during CCS R2 testing.

The operations team commanded the incorporation of its CCS R1 Load Shed Table after the real-time transition to CCS R2. When this happened, the primary C&C MDM failed. When the backup C&C MDM took over, ground software automatically attempted to complete the load of the Load Shed Table, which caused that C&C MDM to fail. Luckily, the third C&C MDM was not configured for Tracking and Data Relay Satellite communications. When the third C&C MDM took over,

the ISS did not have communications with the ground. This allowed the operations team to abort the attempted Load Shed Table uplink.

Upon investigation of the issue, NASA determined that the updated CCS software had been recompiled, which had caused the memory address for the Load Shed Table data to change. The Load Shed Table overwrote critical software when the CCS R1 Load Shed Table was loaded to a C&C MDM that was running R2, thereby causing the MDM to fail. Although the intended content and function of the Load Shed Table did not need to be changed, the actual file needed to be updated to match the recompiled software.

Multiple actions were taken to update the transition process as a result of this incident. First, the transition test procedures were updated to assure that the flight versions of all files were tested. Second, the ground commanding software was updated to abort any attempt to load a file if a C&C MDM transition occurred, thus preventing a bad uplink from taking down multiple MDMs. Third, the Load Shed Table (and similar files) are now being rebuilt for each software load, even if the intended function does not change.

As occurs with visiting vehicle operations, spacewalks, and other dynamic events, the combined operations, engineering, and management teams apply lessons learned from software transitions to future plans. This improves the overall process of upgrading ISS software, which keeps the crew and vehicle safe and ultimately increases scientific output.

## Conclusion

Despite the complexity of the space station, some aspects of its operations are familiar to the average person on Earth, especially when it comes to the need to periodically upgrade software. Due to the scale and critical nature of the software on the ISS, however, the planning and testing process takes about a year. As with any other system, the flight control team needs to adapt and respond to unexpected surprises that can occur, even within a well-orchestrated process.







# Chapter 7 **Systems:**

Motion Control  
System—Navigator  
of the Heavens



*Astronaut Dave Williams carrying one of the four massive gyroscopes used to control the orientation of the International Space Station (ISS) during replacement operations on STS-118/ISS-13A.1 in August 2007. Williams (anchored in a foot restraint) is being moved along with the Control Moment Gyroscope (CMG) by the space station robotic arm. The CMG is being installed on External Stowage Platform-2 near the ISS airlock, where it was stored awaiting a return to Earth for refurbishment.*

***The Motion Control System (MCS) keeps the International Space Station (ISS) “right side up” rotationally as well as maintains the ISS in the proper orbit. Without it, the ISS would simply tumble in space, eventually lose altitude, and reenter the Earth’s atmosphere.***

The MCS maintains the ISS in a constant attitude for day-to-day operations, maneuvers the ISS to special attitudes for visiting vehicle dockings and captures, and reboosts the ISS to counter atmospheric drag or avoid space debris. The system uses Global Positioning Satellites

(GPSs), rate gyroscopes, and other sensors to allow the ISS to “know” its location as it circles the Earth. These data are also used to point solar arrays at the sun, antennas to communications satellites, and payloads to ground or other targets.

The ISS MCS, as it exists today, is a shared responsibility between the US Segment and Russian Segment of the ISS. The core of the Russian Segment MCS was launched as part of the Russian Service Module (SM) on July 12, 2000. Nearly all of the Russian MCS, as it exists today, was activated when the SM was first

launched. The thruster-based control system of the SM was extremely important for the early assembly of the ISS, as it was the only attitude control for the early portions.

Today, the SM continues to provide thruster-based attitude control for larger maneuvers, or to assist the US Segment attitude control system when it cannot provide enough control force. Additionally, Progress cargo vehicles docked to various docking ports on the Russian Segment have thrusters that are commanded by the SM and augment its original thrusters.

The US Segment MCS was built up over several flights, starting with the United States On-orbit Segment (USOS) Destiny Laboratory, which was launched on February 10, 2001. The primary feature of the US Segment is four Control Moment Gyroscopes (CMGs), which can maintain attitude control for weeks at a time electrically without using precious rocket propellants.

Because of its large size and extended lifetime, and because the MCS is shared between the US and Russian segments, the ISS has a number of unique features compared to the motion control systems of other satellites. These features include the following:

- The Russian Segment carries several tons of hypergolic propellant for propulsive attitude control and reboosts. Hypergolic propellants (in this case, a fuel of hydrazine and an oxidizer of nitrogen tetroxide) react and ignite on contact with each other. The propellant is periodically replenished by Progress resupply vehicles launched from Russia (typically around four per year). In the past, propellant was also resupplied by the European Space Agency Automated Transfer Vehicle (ATV). The ISS is the only satellite for which the on-board propellant is periodically replenished; for other satellites, the depletion of propellant usually marks the end of useful life.
- Although the SM houses a complete set of attitude control thrusters and reboost engines, it can also control and automatically fire thrusters and reboost engines on the Progress vehicles that are normally docked to the aft of the SM or on the Docking Compartment-1 (DC-1).

- Most components, including the flight computers in both the US Segment and the Russian Segment, the CMGs, rate gyro assemblies, Space Integrated Global Positioning System/Inertial Navigation System (SIGI) receivers, and antennas can and have been replaced on orbit. In many cases, failed components have been returned, serviced and refurbished, and relaunched for use as spares.

As with everything else on the ISS, computers are at the core of the MCS. The work of the MCS is shared between the US Segment and the Russian Segment, extending to the computer systems at the center of the system. The MCS is built around a portion of the Command and Data Handling System, informally referred to as the “4-Box,” which includes the four-computer systems that manage and execute the motion control task. Two computers on the US Segment and two computers on the Russian Segment work together to control the ISS attitude and orbit. These computers process inputs from sensors such as GPS, star trackers, and rate sensors

(discussed below) while commanding CMGs and small rockets to control the attitude and orbit.

## Command and Data Handling Elements

The 4-Box consists of the Tier 1 Command and Control (C&C) Multiplexer/DeMultiplexer (MDM) and Russian Segment Central Computer and the Tier 2 Guidance, Navigation and Control (GNC) MDM and Russian Segment Terminal Computer. There are three C&C MDMs (Primary, Backup, and Standby) and two GNC MDMs (Primary and Backup). In both sets of computers, the Primary is performing all processing while sharing information with its powered-on and “hot” backup MDM. The Russian Central Computer and Terminal Computer are actually each a set of three independent computers that provide redundancy. See Figure 1.

The C&C MDM and Central Computer manage the overall configuration of the system (such as which segment is in attitude

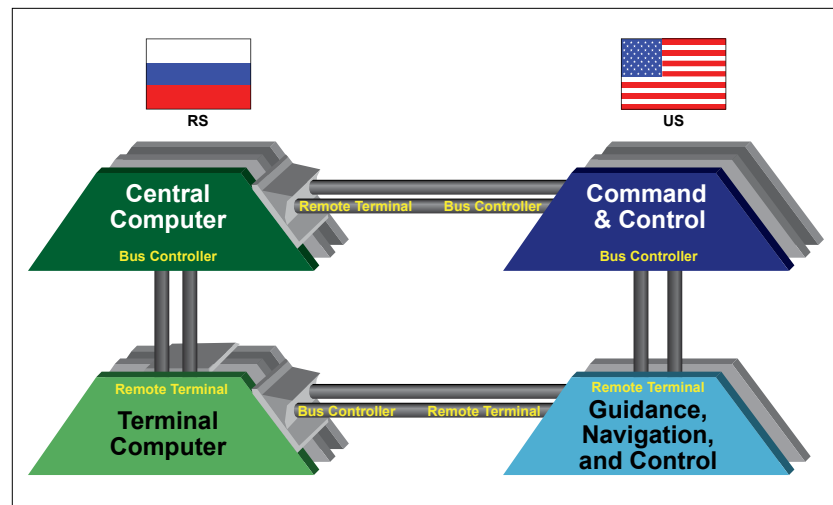


Figure 1. 4-Box computer architecture of MCS.

control), whereas the GNC MDM and Terminal Computer determine attitude and position through the use of sensors, and physically fly the ISS with CMGs and small thrusters under guidance from Mission Control Center-Houston (MCC-H), Mission Control Center-Moscow (MCC-M), and occasionally the crew.

## Vectors and How NASA Uses Them

An important concept to how space vehicles and Mission Control know their location in space and the relative location of other objects is that of the vector. The simplest kind of vector is a location within a coordinate system that is defined by a grid.

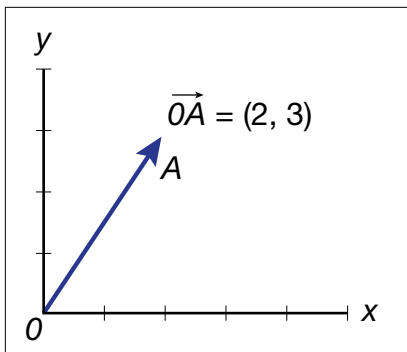


Figure 2. A simple vector.

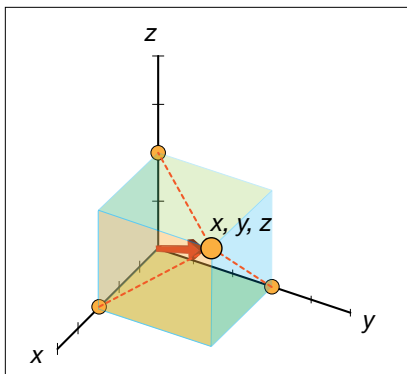


Figure 3. Vector representation in three dimensions.

In Figure 2, the point O is the origin of the system, and the point A is a point of interest at x coordinate 2 and y coordinate 3. Vector OA describes the location of this point in this simple coordinate system.

Figure 3 shows a slightly more complex system, which extends into three dimensions to show the location of point A.

A practical example of the use of a vector is shown in Figure 4. A position vector for the ISS can be described using kilometers in the X, Y, and Z axes by setting a coordinate frame in the center of the Earth. Mathematically, this is how the computers on the ISS and those in Mission Control store knowledge of the ISS position.

The following paragraphs include references to several types of vectors, but all of them essentially describe the position (and sometimes velocity, as well) of one object relative to another object.

## Where Is the International Space Station?

Fundamentally, the MCS senses and controls two elements—the orbit in which the ISS circles the Earth, and the attitude that the ISS holds relative to Earth during that orbit.

The ISS flies a nearly circular orbit inclined 51.6 degrees to the equator and circles the Earth once every 90 minutes. Orbital altitude is typically

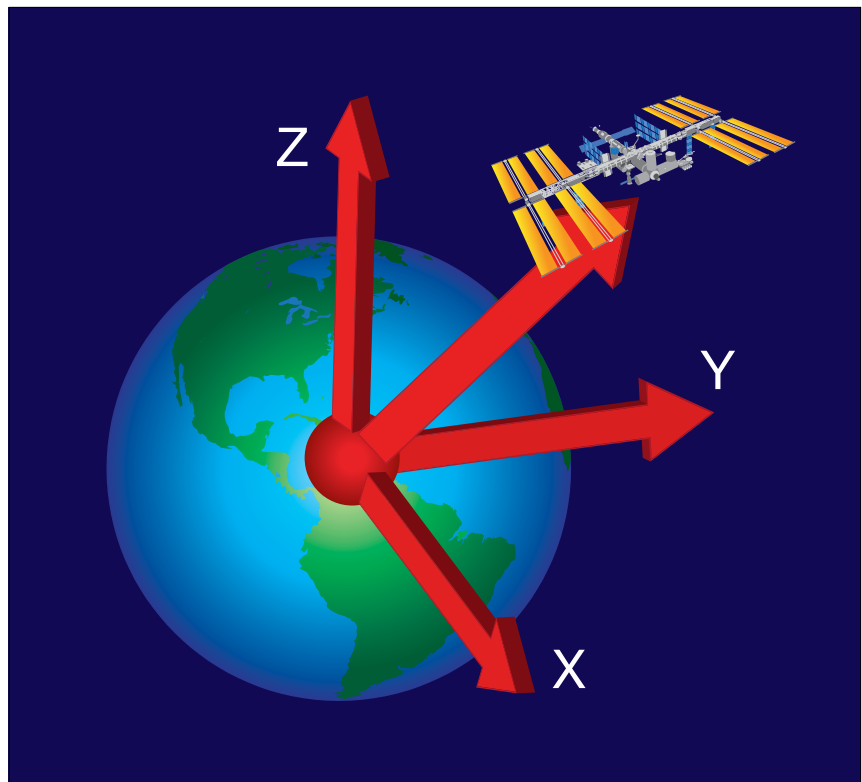
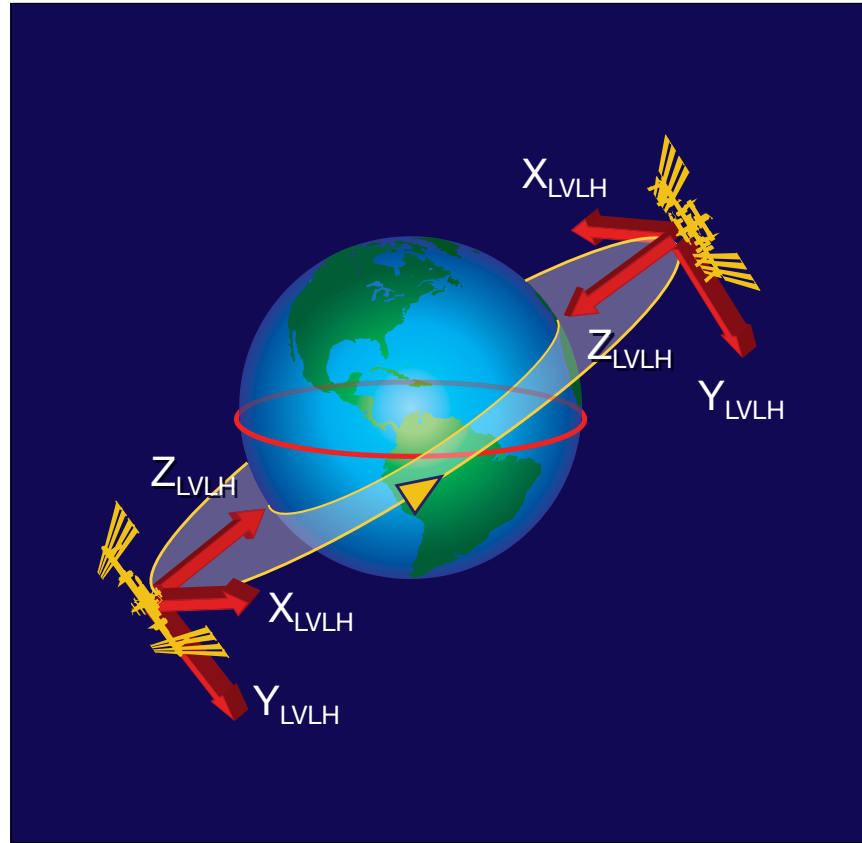


Figure 4. ISS position vector.

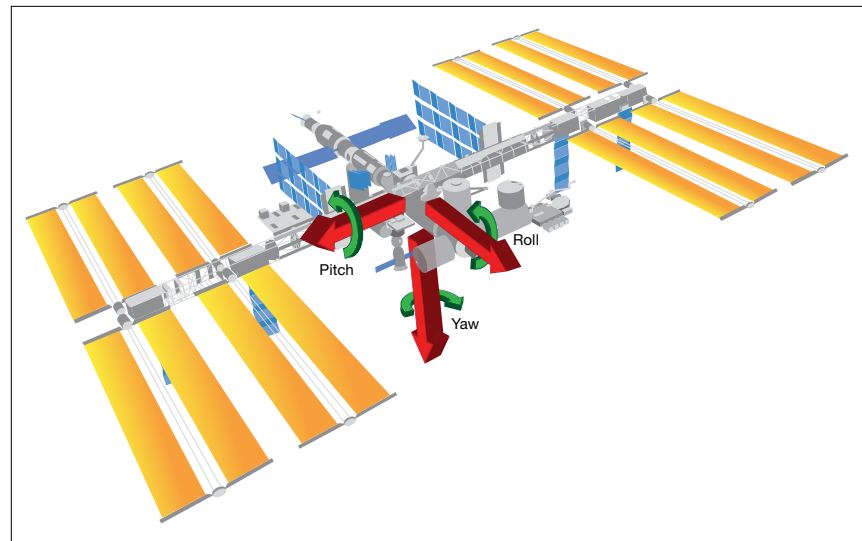
around 410 km (255 miles) above the surface of the Earth, although the exact altitude is manipulated by reboosts and by small manipulations of the drag of the space station through solar array positioning (see Chapter 9). This manipulation of the orbit ensures the ISS is at the correct altitude and position in orbit for the numerous cargo and crew transfer vehicles that rendezvous with the ISS, as well as in the proper position to undock cargo and crew transfer vehicles that return to Earth.

The ISS maintains a rotational position using attitude control while in this orbit. Unlike, for example, an airplane in orbital space, there is no naturally defined “up” or “down” on the space station. The ISS usually performs attitude control within a coordinate frame called Local Vertical, Local Horizontal (LVLH) (see Figure 5). In this reference frame, the +X axis points along the velocity vector in orbit, the +Z axis points toward the center of the Earth, and the +Y axis is perpendicular to the X-Z plane. The frame is referred to as a rotating coordinate frame since the Z axis is always pointed toward the center of the Earth.

The exact attitude of the ISS within this frame is usually described by a Yaw, Pitch, and Roll (YPR) in degrees (Figure 6). When the ISS is precisely aligned with LVLH, it is at an attitude of Yaw=0, Pitch=0, and Roll=0—or, in shorthand, YPR 0,0,0. When at this attitude, if one were sitting atop the ISS, the Earth’s horizon would be visible in front of him or her, as if that person were in an airplane. If the person looked below, he or she would see the Earth. The ISS usually flies within a few degrees of the LVLH



**Figure 5.** LVLH reference frame. Note that the reference frame rotates so that Z (and the bottom of the ISS) always points at the Earth.



**Figure 6.** YPR attitude definitions for the ISS.

attitude, a typical torque equilibrium attitude (which is described later) as the space station coasts is YPR -4,-3,0. Some special attitudes—e.g., a pitch up of 90 degrees for some Russian vehicle undockings—are used for short periods of time, usually for a few hours, at most.

By flying in an LVLH reference frame, the “bottom side” of the ISS faces the Earth as the space station travels around it. This provides some advantages. Scientific packages intended for Earth observation (such as cameras) can be mounted in a fixed position on the underside of the ISS, whereas communications and other antennas are afforded a clear view of space on the top. Thermal protection can be specifically designed for the Earth-facing or space-facing side of the ISS. One disadvantage is the sun will appear to be constantly in motion as the ISS passes beneath it; thus, articulating solar arrays were designed to track the sun and provide maximum power generation.

A final feature of the ISS orbit is the geometry of the ISS orbit with respect to the sun. As the space station orbits, the sun rises and sets every orbit (16 times a day). When the sun is highest in the sky, it is also referred to noon (as on Earth)—or, more specifically, orbit noon, since noon happens once per orbit.

A line drawn from the center of the Earth to the spot on the orbit where orbit noon occurs is called the orbit noon vector. A line drawn from the center of the Earth directly to the sun is called the sun vector. Both of these can be visualized on Figure 7.

The sun can be almost directly overhead at noon or it may be well off to the left or right side of the orbit, depending on the orientation of the

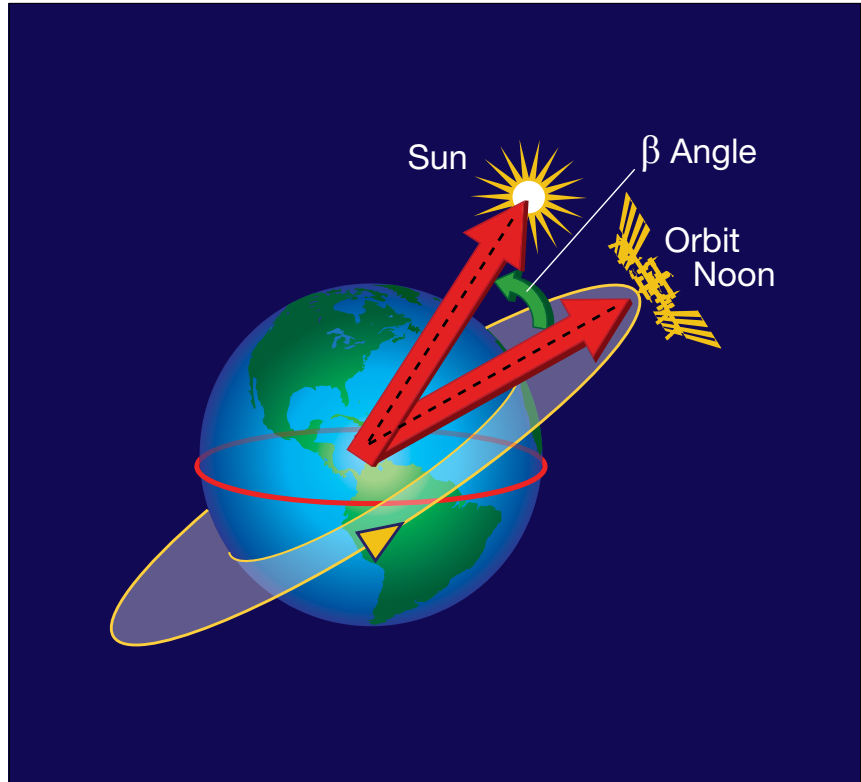


Figure 7. Definition of beta angle ( $\beta$ ).

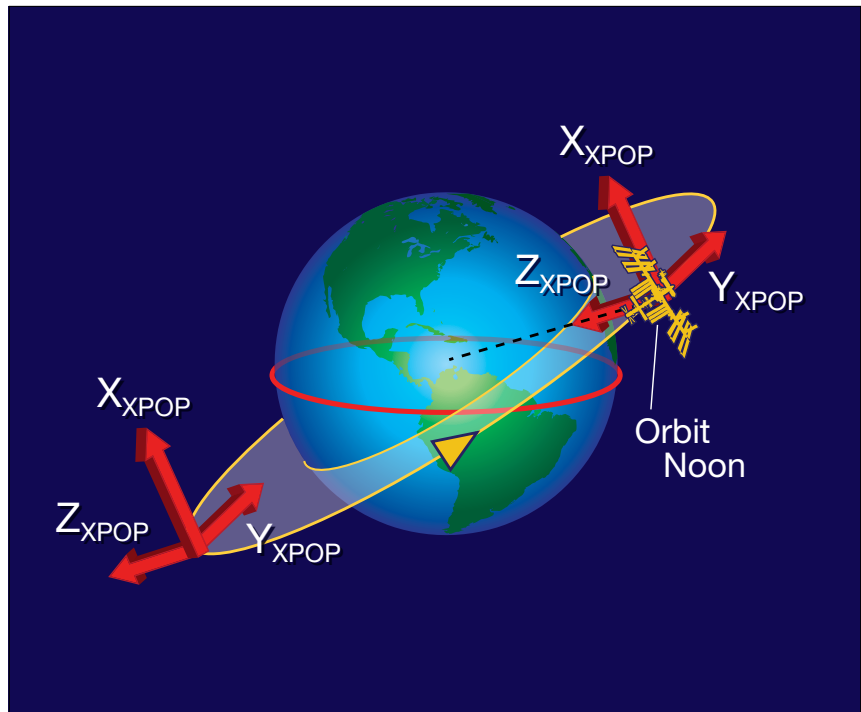


Figure 8. XPOP reference frame.

ISS orbit. The angle between the sun vector and the ISS orbit noon vector, shown in Figure 7, is known as the beta angle ( $\beta$ ). The beta angle varies between +75 degrees (low to the left of the ISS when flying in LVLH), 0 degrees (directly overhead), and -75 degrees (low to the right of the ISS). The exact beta angle is dependent on where the Earth is in orbit around the sun (the sun is over the northern hemisphere in June and over the southern hemisphere in December), and the orientation of the ISS orbit about the Earth (which shifts westward a few degrees per day due to the bulged center of the Earth). The beta angle slowly swings between negative and positive extremes over the course of several months, by a few degrees per day.

The most visible effect of beta angle on the ISS is that of the secondary gimbals on the ISS solar arrays, also known as the beta gimbals. These gimbals are used to turn the arrays to the left or right when the sun is lower in the sky (see Figure 8, Chapter 9).

A reference frame called X-Perpendicular Out of Plane (XPOP) was used for attitude control in the early parts of the ISS assembly, before the full complement of solar arrays and gimbals were installed. See Figure 8.

XPOP is a reference frame that is the equivalent of LVLH with a 90-degree yaw, but only at orbit noon. The frame stays essentially fixed in inertial space, meaning it doesn't rotate as the ISS goes around the Earth, as does LVLH. XPOP was designed to point the ISS toward the sun, which was useful at higher beta angles when the arrays could be placed only in limited positions.

## How the International Space Station knows its Position: Orbit Determination

The orbit of the ISS can be described by a vector consisting of six elements: three elements for position relative to the Earth (X, Y, and Z) as described previously and shown in Figure 4, and a corresponding three elements to describe velocity in each of those axes. That vector is known as a state vector, and is used by the ISS to know its location in space so that it can, for example, properly point antennas at data relay satellites and solar panels at the sun. The state vector is also used by Mission Control to know where to target cargo vehicles. In fact, if one uses personal-computer-based tracking software at home to track the location of the ISS and determine when the space station may be

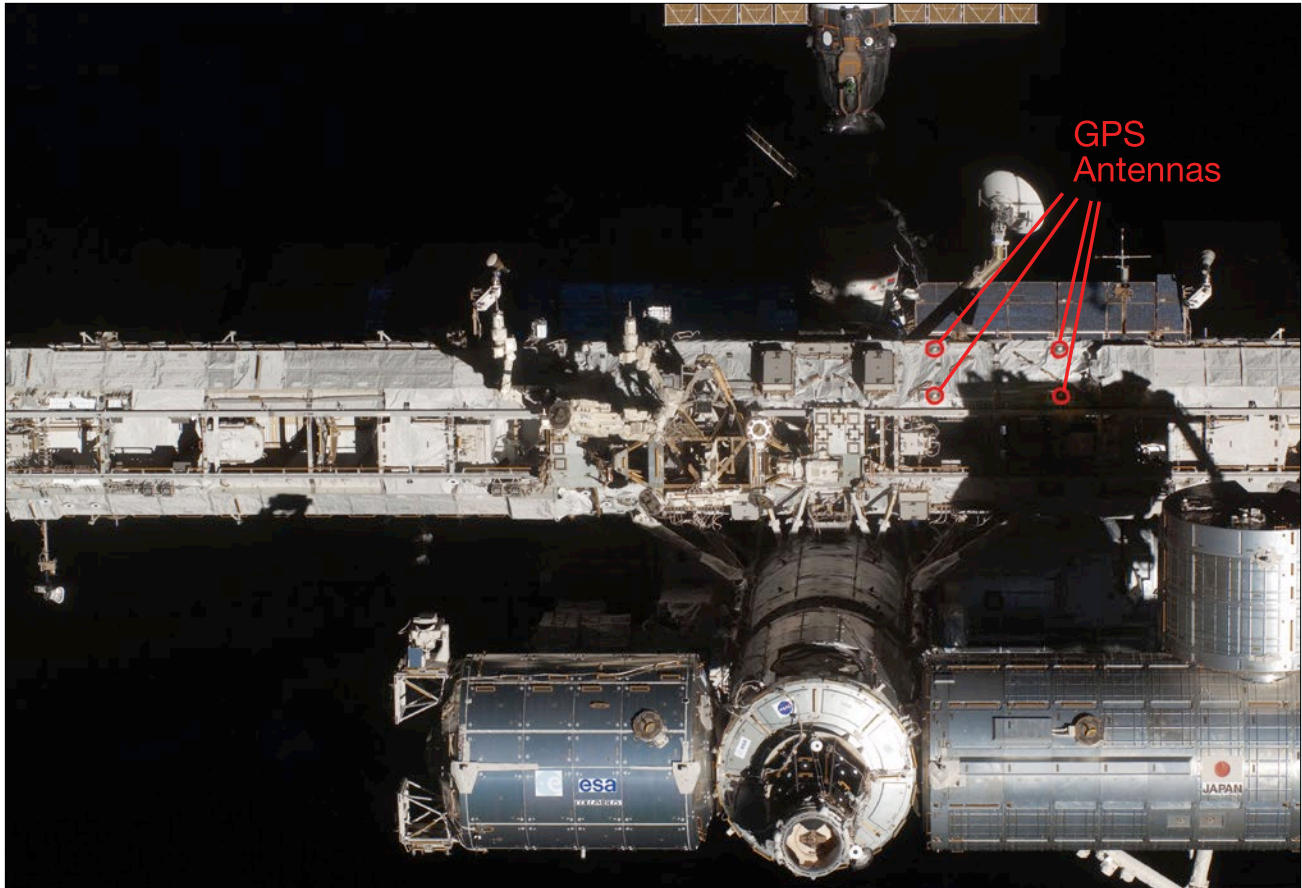
visible, that software is downloading an up-to-date ISS state vector from the internet.

Once the position and velocity are known at a given time, mathematical equations can be used to calculate the position at a future time. This is accomplished through a computer process called propagation; however, the more days a state vector is propagated forward, the more error appears in the result. Because of this, the state vector on the ISS as well as on the ground needs to be updated with sensor-based position determination to correct and update the mathematical propagations.

Orbit position and velocity determinations can be made in a variety of ways for the ISS. The US Segment has a pair of GPS receivers along with an array of four GPS



**Figure 9.** GPS antenna, one of four. The GPS antennas were designed to be replaceable by spacewalking astronauts. In this image, a technician fit checks an antenna while wearing spacesuit gloves to verify the design.



**Figure 10.** GPS antenna array on S0 truss. The rectangle traced out by the four antennas is 3 x 1.5 m (~10 x 5 ft).

antennas mounted on the S0 truss (Figures 9 and 10). These receivers are SIGI units, manufactured by Honeywell (Morristown, NJ). SIGI receivers are common in satellites today, although the ISS was the first to use it operationally.

For the most part, the SIGI receivers determine position in the same way a GPS receiver determines position in a vehicle on Earth. The receiver can triangulate a position of the ISS, as well as compute a time error to the microsecond level between the computer clock running on the ISS and that on board the synchronized atomic clocks on the GPSs, by

receiving coded signals from at least four of the 24 operational GPSs that orbit above the ISS. The position is provided to the navigation software within the USOS GNC MDM to correct the navigation filters, if necessary, whereas the time error is occasionally adjusted by MCC-H to slowly adjust the on-board clock of the ISS (see Chapter 5).

Similar satellite navigation equipment is also installed in the Russian Segment, which determines its own state vector and shares it with the USOS GNC flight software. The SIGI can also determine acceleration; however, this is normally only used

during reboost maneuvers due to the relatively infrequent maneuvers of the ISS, and, even then, only occasionally.

Additionally, tracking by ground radar and Tracking and Data Relay Satellite ranging can be used to determine the orbit of the ISS, although typically these data are used only by the ground. In some rare cases, both MCC-H and MCC-M may command new state vectors to the USOS and/or Russian Segment software when the ground solution is determined to be better or when the satellite navigation equipment in either segment is offline.



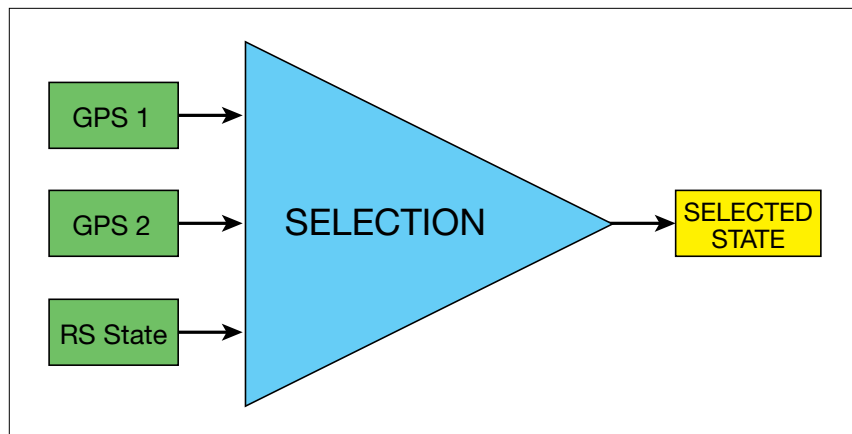
While the position in a particular orbit changes rapidly (8 km/sec [5 miles/sec]), the orbit itself changes little over the course of a day, mostly in the form of a small altitude decrease on the order of 25 to 50 m per day (82 to 164 ft per day) due to atmospheric drag. Because of this, the MCS can easily go for 24 hours or more without a position measurement (also sometimes referred to as a “fix”) to correct its orbit knowledge, although it is rare to go more than 1 hour.

The USOS GNC system actually propagates three different orbit positions in memory—one based on measurements from GPS (SIGI) receiver 1, one based on measurements from GPS receiver 2, and one that is calculated by the Russian Segment Terminal Computer and transmitted to the GNC MDM. The software performs a comparison of the three estimates and will vote out the one that does not agree with the other two in order to isolate errors in the system. Normally, the three estimates will agree within a few tens of meters, and the system will automatically select GPS 1 if all three agree. See Figure 11.

## Attitude Determination

Attitude (rotational position) determination is a more complex problem than orbit determination. Sensors are needed to determine the attitude at specific intervals as well as the changes between those times.

The US Segment also determines the attitude of the ISS using GPSs, but in a fundamentally different way than that in which orbital position is determined. The GPS antenna array



**Figure 11.** Selection of GPS estimates in the USOS GNC software.

is relatively large, and the distance between the antennas is fixed and known. The position of the antenna array in three-dimensional space can be roughly determined by the attitude processor within SIGI by using the phase difference (i.e., time delay) between GPS signals received by at least three of the four different antennas in the array. These fixes can be infrequent (i.e., more than an hour apart). Tracking angles from the USOS Ku-band communications antenna can also be used as a source of attitude information, although this is considered a backup to the GPS (see Chapter 13).

The US Segment has a pair of Rate Gyro Assemblies (RGAs) (Figure 12) mounted in the S0 truss to propagate attitude in between relatively infrequent position fixes. Each RGA consists of three ring laser gyros mounted at 90-degree angles to each other to sense rates about all three axes. Internally, the RGAs measure attitude changes 200 times per second; five times per second, that information is provided to the GNC flight software. The GNC flight software updates its attitude knowledge at the same rate using



**Figure 12.** ISS RGA.

the attitude information to calculate attitude error, which is used by the attitude control function that is described later.

A complex attitude-determination filter in the GNC flight software combines the attitude fixes from GPS or the Ku-band antenna in concert with sensed rate changes and generates a highly accurate filtered attitude as well as estimates of RGA misalignment and gyro drift of the RGAs. With this information, the GNC flight software typically knows its attitude to 0.1 or 0.2 degrees accuracy.

The Russian Segment independently determines attitude using star mappers and its own set of gyros.

Star mappers mounted on the SM take images of the sky and compare the patterns made by the stars in the image to a catalog of the star patterns stored in the software. By matching images to the catalog, software in the star mapper can determine the orientation of the star mapper itself. This information is processed by the Russian Segment Terminal Computer to determine the attitude. The Russian Segment also uses a gyroscope in the SM to determine changes in attitude. This system allows the Russian Segment to determine the attitude of the ISS independently and dissimilarly from the USOS systems.

Both segments share, compare, and can use the attitude information from each other. This sharing, combined with the dissimilar system designs of each system, provides a significant advantage in redundancy, since major failures (e.g., power failures) are usually localized to either the Russian Segment or the US Segment. If the US Segment loses its attitude or rate information, it can easily and automatically switch to that being provided by the Russian Segment. The Russian Segment can similarly use the navigation information computed by the US Segment.

As shown in Figure 13, the USOS GNC software carries three estimates of attitude and three estimates of rate when running at full redundancy, including the estimate delivered by the Russian Segment. The software compares each of the three estimates and will vote out a single estimate that is in error.

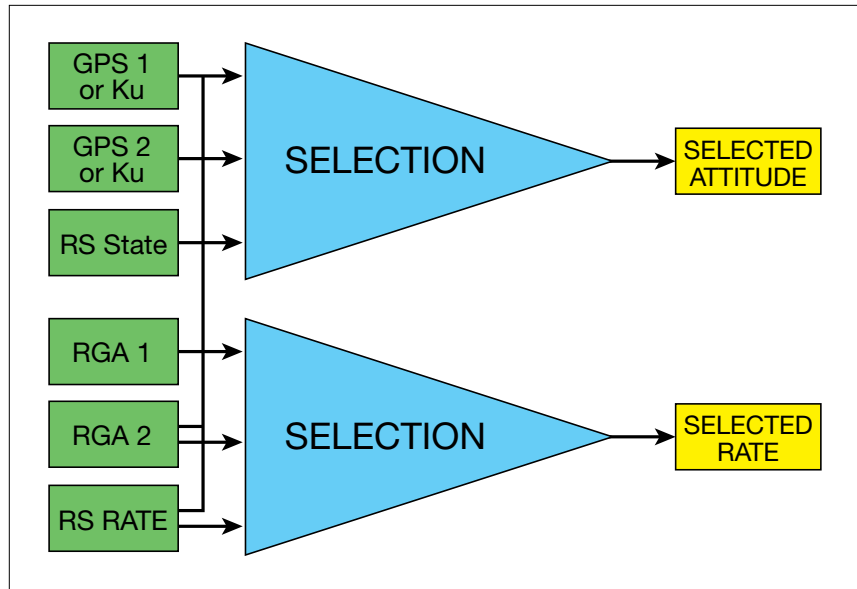


Figure 13. Attitude selection algorithm in the US GNC software.

### How does the International Space Station control its location?

The ISS uses a combination of small rocket thrusters located on the SM and Progress cargo vehicles on the Russian Segment as well as non-propulsive attitude hold devices (i.e., CMGs) on the US Segment to maintain attitude. Occasionally, the orbit may need to be raised or adjusted, which is done with rocket engines on the aft of the SM or those on the aft of a docked Progress cargo vehicle.

The ISS has an elegant arrangement where the duties of attitude control are shared between the US Segment and the Russian Segment. Computers to manage the systems are divided between the segments and share data, and attitude control is handed over between the segments cooperatively, depending on operational demands.

Besides operational needs to position the space station (such as maneuvering to a docking attitude), the MCS counteracts small but significant forces (over time) from the low-Earth orbit environment. Those forces include:

- Aerodynamic drag, primarily due to the large solar arrays. Even though the ISS is in space, its low orbit actually encounters a very thin portion of the atmosphere of the Earth. Overall drag causes the orbit to lose energy and the space station to drop to a lower altitude, requiring periodic reboosts to raise the orbit. Unequal drag on different parts of the vehicle also causes attitude torques (or rotational, twisting force) that tend to push it out of flight attitude, which needs to be constantly counteracted by the attitude control system.

- Gravity gradient forces. Gravitational force acts on an object as a proportion of square of the distance from the Earth. Parts of the space station that are nearer to the center of the Earth are attracted more than ones that are farther away. While on Earth, and for most satellites, the difference would be considered miniscule; the size of the ISS causes relatively significant gravity gradient torques in certain flight attitudes. Again, the attitude control system needs to constantly counter these torques to stay in attitude control.
- Other minor forces, including solar radiation pressure (literally, pressure from light).

At any instant in time, these forces are absolutely miniscule—e.g., the drag from the rarified atmosphere in low-Earth orbit is 100 times less than the force on the human hand when holding a sheet of paper. Over time, however, even this miniscule-but-constant aerodynamic force will cause the ISS orbit to slowly drop, usually on the order of 25 to 50 m (82 to 164 ft) per day, which drives the need for occasional reboots.

These external forces will also act to try to push the ISS out of attitude and cause it to tumble; aerodynamic and gravity gradient forces, in particular, are not evenly distributed. This drives the need for attitude control devices. For the ISS, these devices are CMGs assisted by occasional thruster firings. Electrically powered CMGs are used for gently counteracting environmental forces most of the time, whereas propellant-consuming

thrusters are used for maneuvering and desaturating the CMG system when required (discussed below).

### Controlling Attitude in Space—Control Moment Gyroscopes and Thrusters

Two general categories of activities require attitude control. One is regular day-to-day operations where the ISS is maintaining a LVLH attitude and a stable platform for other vehicle systems and payloads. During these operations, only small adjustments are needed to be applied by the control system to counter the tiny forces introduced by aerodynamic drag and gravity gradient forces.

The other category is special operations, where control of the ISS attitude may require rapid rotational maneuvering of the ISS attitude, use of stronger methods of attitude control during rendezvous operations of visiting vehicles, reboost operations, or recovery from an unplanned loss of attitude control.

Two primary methods are employed to control the attitude of the ISS for these operations (Table 1). CMGs on the USOS MCS system perform fine attitude control using only electricity readily available from the Electrical Power System, and typically are fully in attitude control during day-to-day operations. Thrusters on the Russian MCS can be called upon to augment or take over attitude control from the CMGs during special operations. Although the thrusters offer more power, it comes at a cost of consuming propellant (which must be resupplied from Earth), increased operational complexity, and the potential to interfere with payloads dependent on a microgravity environment.

The effectors of the USOS MCS system consist of four CMGs. The CMGs each consist of a 98 kg (216 lbs) steel flywheel, which is spun by an electric motor at a constant rate of 6600 revolutions per minute. The flywheel sits on two mechanical, lubricated spin bearings that are electrically driven to keep the CMG running at full speed. The flywheel and spin bearings are mounted on

**Table 1.** Comparison of CMGs and Thruster Control

Type of Control	CMGs	Thrusters
Advantages	<ul style="list-style-type: none"> <li>• Use only electricity.</li> <li>• Can hold attitude tightly.</li> <li>• No potential to damage solar arrays.</li> <li>• Do not interfere with microgravity payloads.</li> </ul>	<ul style="list-style-type: none"> <li>• More powerful, can perform larger maneuvers.</li> <li>• More robust (can maintain attitude control when CMGs would be overwhelmed).</li> </ul>
Disadvantages	<ul style="list-style-type: none"> <li>• Limited power.</li> <li>• May require augmentation by thrusters for larger maneuvers or tighter control.</li> </ul>	<ul style="list-style-type: none"> <li>• Require resupply of propellant from Earth.</li> <li>• Can require special positioning of solar arrays to avoid damage.</li> <li>• Spent propellant can cause contamination, especially for windows.</li> <li>• Firing may interfere with microgravity payloads.</li> </ul>

an electrically driven inner gimbal, which in turn is mounted completely inside an outer gimbal. Because of the inner/outer gimbal design, the spin axis of the flywheel can be oriented at any position within three-dimensional space.

A CMG (Figure 14) is a device that produces torque (a rotational, twisting force). A torque is generated on the space station by electrically driving the inner and outer gimbals and pushing or “gimbaling” the spinning wheel. Compared to the size of the ISS, the torque is surprisingly small, usually 10 to 30 N-m (7 to 22

ft-lbs) depending on the velocity at which the gimbals are being driven by their motors. For a comparison, if a person could stand at the end of the space station truss, he or she could impart the same level of torque by simply pushing.

Since the environment around the ISS consists of external forces that are much less than those encountered on Earth, the relatively low torque output of the CMGs is sufficient for all attitude control—except when large maneuvers need to be performed quickly. The ISS uses four CMGs, mounted on the Z1 truss segment, that

work together in tandem under the command of the USOS GNC MDM flight computer.

The MCS uses the CMGs to generate torque and correct the attitude when small external rotational forces act to push the space station out of its flight attitude. Applied over time, that torque is stored as momentum in the CMG system (momentum=torque multiplied by time). Since the gimbals of the CMGs can constantly be in motion and are powered electrically, they can provide a constant, fine attitude control that counteracts the small aerodynamic and gravity gradient

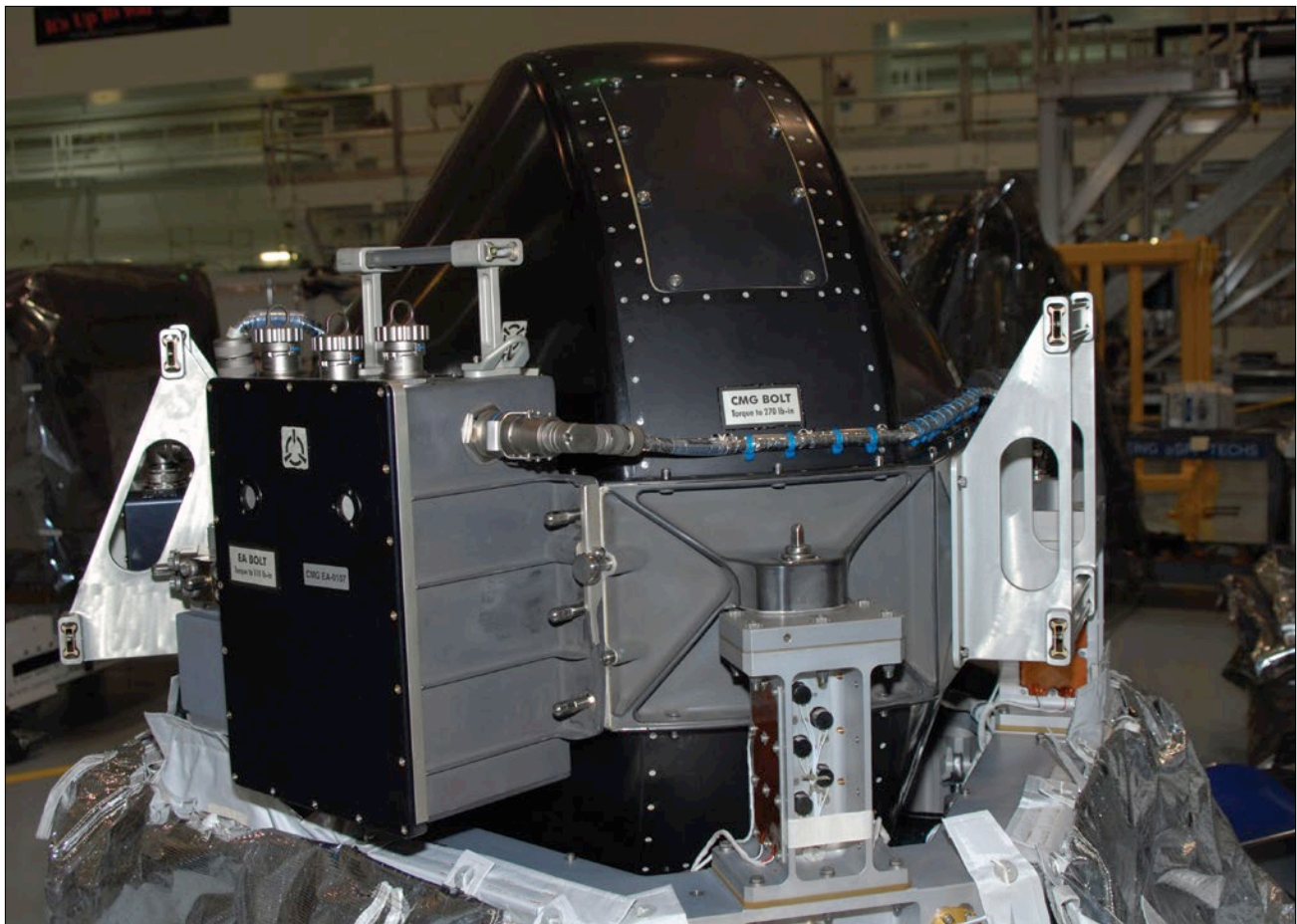
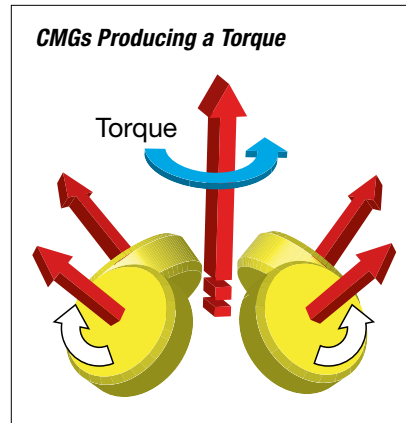


Figure 14. A CMG prior to launch. The large box mounted on the left houses the power supplies and small computer that controls the CMG. The CMG measures approximately 130 x 130 x 130 cm (51 x 51 x 51 in.) and weighs 272 kg (600 lbs).

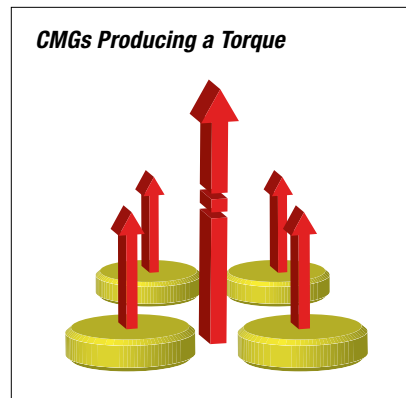
torques. Although CMGs provide excellent fine attitude control, they have a capability limited by physics as the CMGs gimbal. Generally, their momentum axes are pointed in different directions (Figure 15). As the CMGs provide torque and absorb momentum, the spin axes of the flywheels begin to align. When the spin axes of the four-CMG system line up, the system loses control and is referred to as saturated (Figure 16). The CMG system will become saturated relatively quickly for any significant torques (e.g., a small air vent overboard will saturate the CMGs within a few minutes) and they are normally incapable of performing an attitude maneuver of more than about 1 degree, unless the CMG maneuver is specially designed.

The number of CMGs (four) was determined by how much momentum would be required to maintain this fine control during normal day-to-day operations in momentum management (explained below). The ISS simply maintains its attitude during these periods as the crew lives and performs research in between events such as visiting vehicle arrivals and reboosts. The basic capability was to maintain momentum management control without firing thrusters to support microgravity research and conserve propellant over long periods of time (~30 days). Three CMGs were required to meet this minimum level of capability. A fourth CMG was added to introduce redundancy, so operations could continue uninterrupted in the event of a failure.

In comparison, a thruster provides a translational force that acts as a torque when applied over a distance between the thruster itself and the



**Figure 15.** CMG system with spin axes well separated and able to react to external forces.



**Figure 16.** CMG system with spin axes aligned. This CMG system is saturated and the wheels need to be repositioned (this will require thruster firings, also known as desaturations).

center of mass of the space station. Thrusters are significantly more powerful sources of force and torque, and they control the attitude of the ISS more coarsely than the CMGs. Thrusters are used to perform large attitude maneuvers such as those required to reposition the vehicle attitude for dockings. Thrusters are also used to help control vehicle attitude when the CMGs become saturated. In a process called desaturation, the CMG gimbals are moved out of alignment while the thrusters fire to absorb the torque

generated. Desaturation is an automatic software function on the ISS, where the USOS GNC MDMs compute a “desaturation request” (i.e., essentially a vector with desired momentum correction) and hand it off to the Russian Segment Terminal Computers. While the GNC MDM gimbals the four-CMG system to a lower momentum state, the Russian Segment Terminal Computer computes and fires thrusters on the Service Module and/or Progress vehicles to react to the CMG desaturation event and maintain the attitude of the ISS.

In some cases, the CMG system may not be able to maintain attitude control for difficult attitude control situations such as an overboard vent, a problem in the GNC MDM or its software, or the loss of multiple CMGs due to an electrical failure. In these cases, software in the C&C MDM will automatically hand over attitude control to the Russian Segment thrusters or, in limited scenarios, the crew may perform the handover manually in response to a warning message.

Although thrusters are powerful devices, they have disadvantages. Most obviously, they use propellant that needs to be replenished, and that must be launched from Earth. Several tons of propellant must be launched to the ISS, annually, using Russian cargo vehicles.

Another major but less-obvious concern is the health of the ISS solar arrays. The ISS solar arrays are lightweight and were built to be deployed and unfurled on orbit. Because of this, the arrays and the structure that supports them are quite fragile. Imagine a large version

of a model made of tissue paper and toothpicks. Thrusters generate exhaust, which can flex and fatigue the arrays or slowly build up on the panels, thereby decreasing electrical generation. When thrusters are fired, the ISS solar arrays often need to be parked in particular positions to avoid being damaged by the thrusters, which usually reduces the amount of available power.

Finally, the firings from the thrusters are not conducive to a microgravity environment for many payloads. Because of this, CMGs are in attitude control 99% of the time, with control being handed to thrusters for special events only, or in contingency cases such as loss of CMG attitude control or unplanned CMG saturation.

Having both CMGs and thrusters available and working is critical to maintaining attitude control. Without thrusters, large maneuvers could not be performed, the ISS stack could not recover from a loss of attitude control event, and the ISS stack could not be put into position to dock or capture a rendezvousing vehicle. Without CMGs available to hold attitude between these events, the thrusters on the ISS would exhaust their fuel supply in a few months. A minimum of two CMGs are required to perform attitude control; however, three CMGs are generally required to safely perform all attitude control functions. Individual CMGs can be replaced by a spacewalking astronaut with the assistance of the Space Station Remote Manipulator System (SSRMS) robotic arm. Two spare CMGs are carried externally on the ISS to replace failed gyros.

## Microgravity

Probably the most well-known environment the ISS provides is one that is unique to space—an environment in which objects are weightless. Researchers can remove the variable of gravitational influence within their investigations. For example, on Earth, combustion is driven by convection, where warm air rises and cold air sinks. Crystal structures grown in the weightlessness of space can often be grown larger and more pure.

Extremely sensitive experiments such as crystal growth experiments or those involving liquid flow may be negatively impacted by firing of the ISS thrusters, or even by movement of the ISS crew. For these reasons, more sensitive experiments may be run in racks that have vibration isolation, are usually planned when the USOS CMGs are in attitude control and thruster firings are not planned, and may be conducted at night when the crew is sleeping.

## US Segment Attitude Control

The control system of the US Segment attempts to control three different variables: the attitude (how many degrees out of the desired attitude is the ISS located); attitude rate (how fast is the ISS rotating); and momentum (how close are the CMGs to saturation and therefore losing attitude control without resorting to thrusters). How much each of these variables, or controller states, are weighted by the attitude control software depends on how the software is configured. For example, some software controllers are designed to hold attitude and attitude rate (i.e., how quickly the attitude is changing, in degrees per second) tightly, but at the expense of allowing momentum to build in the CMGs and therefore requiring thruster firings. This type of controller is used for dockings but is unsuitable for attitude control of more than a few hours because it uses propellant. A

non-propulsive controller is desirable for most attitude control—i.e., over 99% of the time. These controllers take advantage of the environment in which the ISS flies.

External torques, and the associated momentum gain in the CMG system, often balance out over the course of an orbit. For example, as the solar arrays rotate, they can generate a torque in one direction at one part of an orbit, and then a corresponding torque in the other direction in another part of the orbit. The torques are conservative (i.e., they add up to zero) over a full orbit, with the CMGs providing the mechanism to store momentum on one side of the orbit by gimbaling one direction, and then disperse the momentum on the other side of the orbit by gimbaling the opposite direction.

The CMGs also absorb small, unbalanced (on average) torques in orbit. Over the course of many hours, these unbalanced torques

would eventually saturate the CMG system and require thruster firings. By slightly changing the attitude of the ISS, however, the attitude control software can push the momentum state of the CMG system lower by manipulating the small aerodynamic and gravity gradient torques acting on the system. This software control mode is called “momentum management.” The controller keeps the momentum variable at the lowest while loosening up on the attitude and attitude rate constraints.

While in momentum management, the ISS attitude will gently rock by several degrees over the course of an orbit as the software works to push the momentum state of the CMGs to zero. The advantage of momentum management control is that thruster firings are never needed unless a significant unexpected force such as a vent acts on the system. This saves propellant and preserves the microgravity environment for many of the ISS payloads. The disadvantage is that the attitude wobbles by several degrees, which is unsuitable for precision alignment of the ISS attitude required for vehicle dockings. Momentum management is also unsuitable for rejecting thruster plume disturbances from nearby vehicles, which is why it is not used for visiting vehicle capture operations performed with the SSRMS robotic arm. Finally, momentum management only works near certain attitudes in which external forces are balanced. These attitudes are called Torque Equilibrium Attitudes (TEAs). The most typically flown TEA is one that is usually within a few degrees of the ISS LVLH (0,0,0).

A different control logic—referred to as “attitude hold”—is used for precision attitude alignment and disturbance rejection, or for attitudes that are not at the TEA. In attitude hold, the CMG system maintains the attitude precisely (within a few tenths of a degree) by prioritizing controlling the attitude and attitude rate control over keeping the total momentum constant. This greater stability allows the system to reject strong disturbances, thus making attitude hold suitable for vehicle dockings and robotic capture operations. CMG momentum can build rapidly in this mode since the attitude control software does not attempt to optimize the ISS attitude to control gravity gradient or aerodynamic torques, and the stack may not be at a TEA. In these cases, the system may saturate in minutes, and would require frequent desaturation firings of Russian Segment jets.

A variation of the attitude hold logic is called the USOS Thruster Only (USTO). In USTO, the USOS software bypasses the CMG system and commands thruster firings of the Russian Segment directly by manipulating the software logic used for CMG desaturation firings.

These attitude control concepts are implemented in the software in the form of controllers, which are loaded by the ground as mission needs dictate. These three types of controllers map directly to the above attitude control concepts:

- Momentum management controllers for use during quiescent orbit operations.

- Attitude hold controllers for fine control.
- Attitude hold controllers (USTO logic implemented) for direct USOS control of Russian Segment thruster firings.

## Russian Segment Attitude Control

The Russian Segment performs attitude control using thrusters spread throughout the Russian Segment. The SM contains the original Russian Segment thruster package that is still in use today. Additionally, Progress vehicles docked to the aft port of the SM and the Nadir port of the DC-1 docking compartment have thrusters that are usually placed under control of the SM, when present. Although no longer in use, the European Automated Transfer Vehicle, when docked to the SM aft port, was also controlled by the SM.

The Progress and ATV thrusters are generally preferred to the SM thrusters because the distance between the thrusters and the center of mass of the ISS, or the moment arm, is large. As when using a lever, the longer the moment arm, the greater the mechanical advantage and the less a thruster needs to fire. Additionally, unlike the SM, the Progress and ATV are not permanently attached; therefore, they are unconstrained by lifetime usage limitations that affect the Zvezda thrusters, which have been in use since 2000.

The terminal flight computer within the SM performs attitude control with thrusters when the Russian Segment is in attitude control, and responds to requests for desaturation thruster firings from the USOS GNC MDM when the US Segment is in attitude control.

## Control Modes

The US Segment and Russian Segment flight software jointly works together through the use of several attitude control software modes. The software mode depends on what is operationally being done and which segment is in attitude control.

The most common modes are listed below (see also Table 2):

- Free Drift/Indicator—segment is not controlling attitude.
- CMG/Thruster Assist—US Segment controlling attitude with CMGs, Russian Segment supporting with CMG desaturation firings when commanded from the US Segment.
- Thrusters—Russian Segment controlling with thrusters.

Typically, the configuration of the MCS will be CMG/Thruster Assist during routine orbit operations, with the US Segment in attitude control using a momentum management

controller. The software is jointly reconfigured by both MCC-H and MCC-M to do a dynamic operation. The example in Table 3 illustrates the procedure for configuring from day-to-day momentum management to a configuration to support reboost. Times are referenced to time of reboost burn ignition, or time of ignition (TIG), in minutes. TIG is used as a countdown for reboost burns, which helps Mission Control personnel sequence out activities required to perform the burn.

The US and Russian flight control teams jointly manage all of these operations by using a common set of flight procedures that are built

**Table 2.** US Segment/Russian Segment Control Mode Combinations

Configuration	US Mode	Russian Mode	Notes	Usage
Free Drift	Free Drift	Indicator or CMG/Thruster Assist	No active attitude control.	Used immediately after docking while the docking interface is being made rigid.
CMG/Thruster Assist	CMG/Thruster Assist	CMG/Thruster Assist	US Segment controlling attitude with CMGs.	Momentum management for quiescent operations, US control for vehicle grapples and capture.
Thrusters	Free Drift	Thrusters	Russian Segment Controlling with Thrusters.	Large attitude maneuvers, Russian Vehicle dockings, reboosts.

**Table 3.** ISS Reboost Timeline

Time	Center	Action	Notes
TIG - 40 min	MCC-H/MCC-M	Uplink prep commands through Tracking Data Relay Satellite	
TIG - 30 min	MCC-H	Command handover to Russian Segment	USOS Mode = Free Drift Russian Mode = Thrusters
TIG - 25 min	MCC-M	Command reboost sequence to start	
TIG - 20 min		Attitude maneuver to reboost attitude	Under Russian Segment automatic software control
TIG		Reboost ignition	Under Russian Segment automatic control
TIG + 10 min	MCC-M	Maneuver back to normal stage TEA attitude	
TIG + 20 min	MCC-H	Command handover from Russian Segment	USOS Mode = CMG/Thruster Assist Russian Segment Mode = CMG/Thruster Assist



and tested together. Flight directors and motion control flight controllers at each center jointly manage, over voice circuits, procedures and authorizations for commands.

## Assembling the Motion Control System

The ISS MCS has gone through several evolutions throughout the assembly sequence. Initial capability was provided with the launch of the Functional Cargo Block (FCB) with its basic propulsive control system used for attitude control from launch, by the addition of the Node 1 on Dec 6, 1998, and until arrival of the SM on July 26, 2000. Upon arrival of the SM, the FCB control system was permanently shut down and converted to propellant storage.

During the next 7 months, the SM provided attitude determination and attitude control using thrusters, with orbit determination being done via ground-based radar. The USOS CMGs arrived with the Z1 truss during Space Transportation System (STS)-92/ISS-3A in October, although the CMGs were inactive.

The CMGs were activated and the first attitude control handover was performed to the USOS MCS following the arrival of the USOS Destiny Laboratory on February 10, 2001, along with the necessary flight computers and software. The USOS MCS and CMGs have performed normal day-to-day attitude control since this first activation, with Russian thrusters engaged only every few weeks for larger attitude maneuvers, reboosts, or docking/capture of cargo or crew transport vehicles.

The arrival of the last major assembly—the S0 truss on STS-110/ISS-8A in April 2002—completed the ISS control system. The S0 truss mounted the two RGA attitude rate sensor packages and four GPS antennas (with the SIGI GPS receivers launched earlier in the USOS Laboratory). This upgraded equipment, along with a software update to the GNC and C&C MDMs, allowed the US Segment to fully determine attitude, attitude rate, and orbits independent of the Russian Segment, thus greatly extending the redundancy of the ISS MCS.

This completed the initial system assembly. Although assembly and reconfiguration of the system continues in some respects, each Progress vehicle is used for auxiliary propulsive elements, primarily to provide reboost engines and augment roll control with thrusters. Additionally, software continues to be incrementally upgraded to take advantage of operational experience, such as using the Ku-band antenna to help determine attitude along with the GPS receivers.

## Control Moment Gyroscope Failures

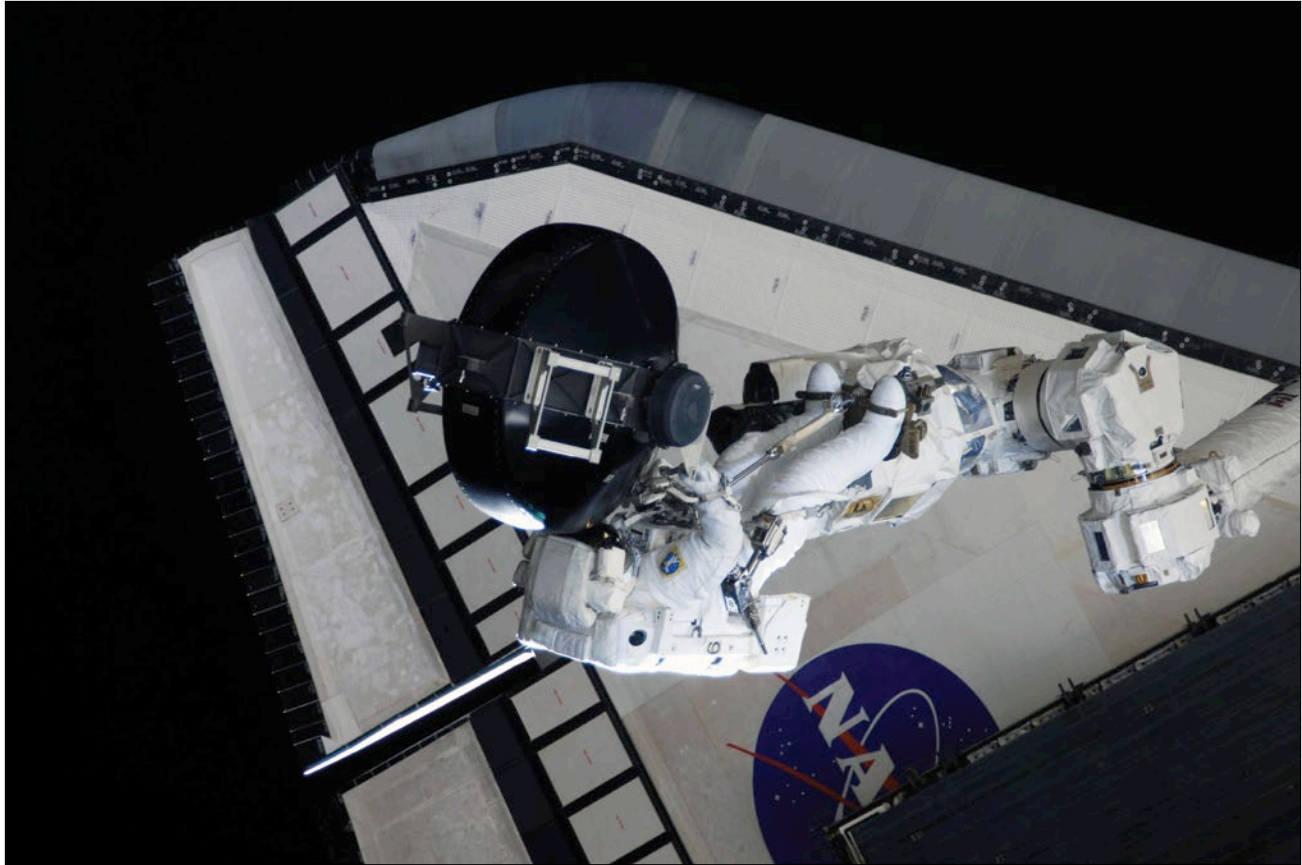
The CMGs were the subject of a considerable engineering and test effort while under development because of their criticality, and the fact these mechanical devices must spin at a high speed for decades. The first CMGs used in space were developed for the Skylab Program, which used three CMGs. During the relatively short Skylab operational mission, one CMG suffered a spin bearing failure and was shut down,

and a second was near failure. The ISS CMGs were direct descendants of the 1973 Skylab CMGs. NASA made improvements in the bearing design to increase the operational lifetime.

Despite this effort, problems with the CMGs continued early in the ISS Program. The CMGs were activated on February 12, 2001, during STS-98/ISS-5A, after being launched late in 2000 and stored with only survival heaters active on the Z1 truss. These CMGs were responsible for nearly all of the ISS attitude control after that time.

On June 8, 2002, controllers in MCC-H noticed that, after little more than a year of operations, CMG-1 vibrated as it spun. Over the next several hours, the vibrations worsened until one of the two mechanical spin bearings failed. It took more than an hour for the energy in the spinning wheel to dissipate, at which time one side of the bearing assembly became so hot it melted the ball bearings inside. The crew reported a sound, which astronaut Carl Walz described as “a pretty loud, audible noise. A kind of growling noise in the Node.” The CMGs are mounted in the Z1 truss, which in turn is mounted to the zenith port of the Unity Node. As with all key elements of the ISS, the CMGs can be replaced (Figure 17).

After a great deal of concern over the health of the remaining three CMGs, especially during the stand down following the Space Shuttle Columbia accident in 2003, NASA replaced CMG-1 during STS-114/ISS-LF1 in 2005 and returned the gyroscope to Earth. CMG-3 exhibited similar issues shortly after CMG-1 was returned. CMG-3 was eventually shut down and



**Figure 17.** Astronaut Dave Williams works to replace a CMG during STS-118/ISS 13A.1.

replaced, as well. A postmortem investigation indicated design issues within the spin bearing that caused the ball bearings to skid instead of roll, exacerbated by relatively high gimbal rate limits.

The CMGs exhibited no additional signs of distress following software modifications to slow down the maximum rates of the gimbals from 3 deg/s to 0.8 deg/s. Furthermore, the two spares stored on the ISS have an improved bearing design based on lessons learned from the failures of CMG-1 and CMG-3.

## Conclusion

Although the MCS can only fully support the ISS by combining the vastly different US Segment and Russian Segment systems, both systems complement each other well. The USOS system provides a smooth microgravity attitude control capability that minimizes the use of on-board propellant consumables, and the Russian Segment system provides the necessary thruster capabilities to handle reboosts and attitude control situations beyond the capabilities of the CMGs.

As with the systems on orbit, flight controllers in both MCC-H and MCC-M work closely together to keep the complete ISS MCS in good health for the purpose of supporting a stable platform for both the crew and the research program.





# Chapter 8 Day in the Life:

Debris Avoidance—  
Navigating  
the Occasionally  
Unfriendly Skies  
of Low-Earth Orbit



*The potentially destructive nature of space debris. This photo (from a ground test) shows the damage done to a solid block of aluminum by a small 7-g (0.2-oz) projectile traveling at 7 km/s (4.3 miles/s).*

***The low-Earth orbit environment in which the International Space Station (ISS) flies is, compared to anything on the Earth, a very empty place.*** But it is not completely empty.

The detritus of more than 50 years of human activity in space encircles the Earth as a cloud of orbital debris—a nearly invisible threat to every satellite in orbit, including the ISS.

### **Orbital Debris—A Serious Threat to all Spacecraft**

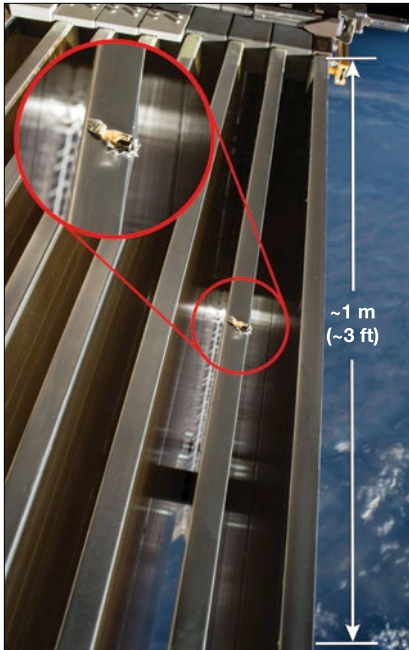
Similar to the way the ocean floors across the globe are the final resting place for shipwrecks from thousands

of years of human seafaring, the remnants of more than 50 years of human activity in space has left bits and pieces of hardware that continue to orbit the Earth.

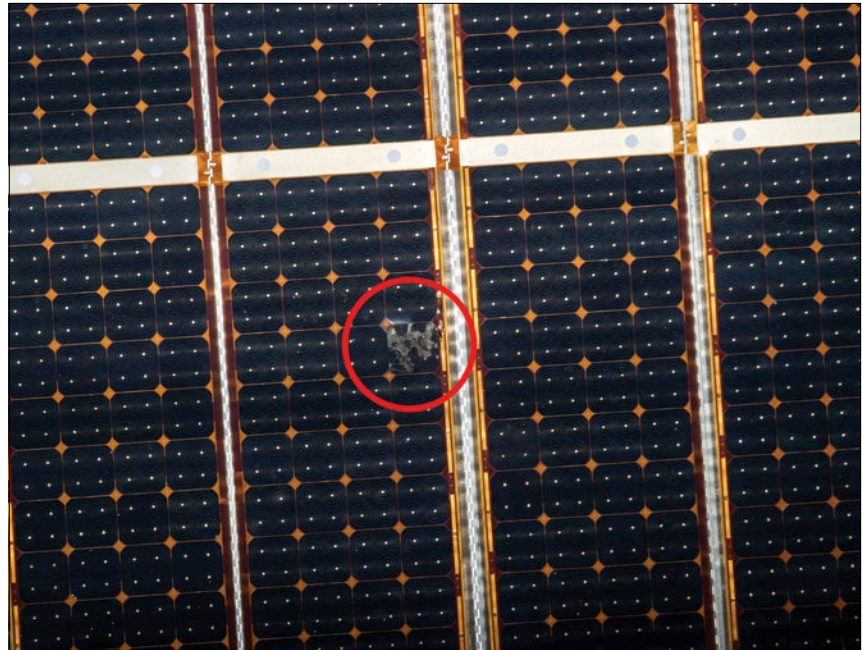
This debris (popularly known as “space junk”) consists primarily of dead satellites, expended stages from rocket launches, and fragmentation from collisions, explosions, or other breakups of these initially large pieces of hardware—sometimes decades after their mission has ended. The size of the junk ranges from multi-ton satellites and rocket stages to small-piece parts of satellites such as nuts and bolts, and even paint chips.

These objects all orbit the Earth at up to 28,000 km/h (17,500 miles/h) in various orbits, meaning that any encounter between them and an operational satellite such as the ISS will usually be at extremely high velocities and would result in a hypervelocity-impact collision.

The effects of a collision on a satellite can range from minor to catastrophic, depending on the velocity and especially the size of the impacting object. Many instances of damage have occurred from collisions between operational spacecraft and space debris.



**Figure 1.** Damage to the Trailing Thermal Control Radiator on the P6 truss segment was noticed during a spacewalk in August 2016.



**Figure 2.** Damage to space station solar array by space debris.

For example, on Space Transportation System (STS)-93, a collision with a paint chip put a 10-mm (0.4-in.) crater into one of the windows of Space Shuttle Discovery, thus leading to its replacement, post mission.

The ISS, having been in orbit since 1998, bears the scars of many impacts, including a hole in the edge of a radiator panel on the P6 truss segment (Figure 1), and a shattered portion of a solar array (Figure 2) that was caused by a piece of small debris.

Without question, the most dramatic event was the collision between the active Iridium 33 communications satellite and the abandoned Kosmos 2251 military communications satellite. The 950-kg (2094-lb) Kosmos and 560-kg (1234-lb) Iridium collided at 42,120 km/h (26,173 miles/h). This collision resulted in the complete destruction of both satellites,

and generated more than 1,000 new pieces of space debris that were larger than 10 cm (4 in.) in diameter.

The US Department of Defense (DoD) actively tracks (and helps NASA and the ISS avoid) objects as small as 10 cm (4 in.) in low-Earth orbit. Approximately 23,000 objects of this size, other than a few hundred active satellites, are currently in orbit and are classified as orbital debris.

Based on ground-based sensors, examination of returned satellite parts, and statistical methods, scientists believe approximately 500,000 objects that are greater than 1 cm (0.4 in.) are in orbit. The population of objects in recent years has increased due to events such as the Iridium/Kosmos collision described above.

## Hypervelocity Impacts

A hypervelocity impact releases a tremendous amount of energy for a given amount of mass, much more so than (for example) a bullet striking a target. Bullets travel on the order of 3500 km/h (2175 miles/h), and typically punch holes in targets.

Relative velocities of two objects on a collision course in orbit are roughly 10 times this much, and the collision for the bullet example would involve 100 times as much energy. At this kind of impact velocity, the resulting release of energy is essentially an explosion.

## Orbital Debris—Conjunctions and Relative Velocities

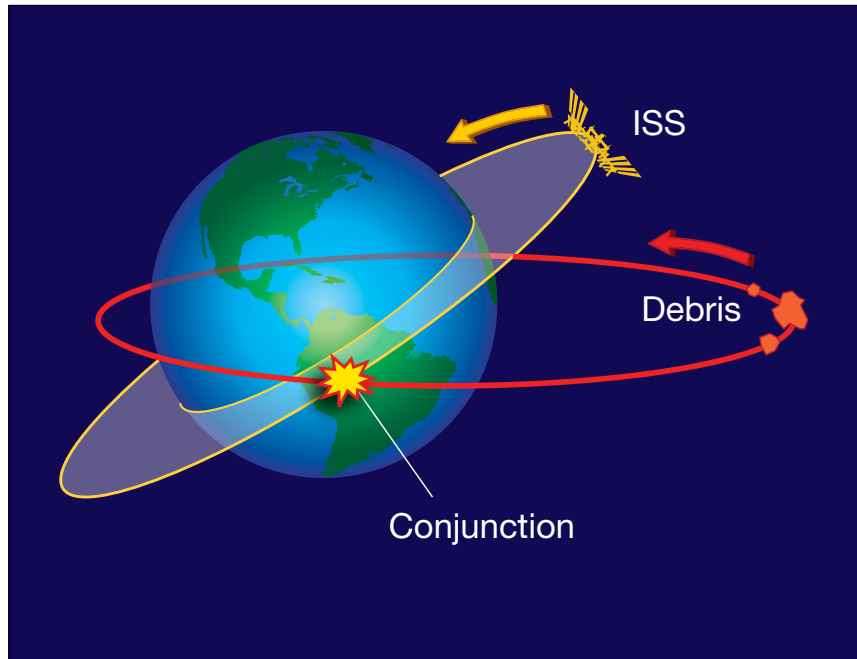
Although debris comes from many sources, most travel at a very high speed relative to the ISS, due to orbital mechanics. This chapter will examine a common debris source: spent rockets.

Many communications satellites operate at a high altitude (37,000 km [22,991 miles]) that causes them to orbit at the same rate in which the Earth rotates. This process is termed geosynchronous. As a satellite travels to that altitude when first launched, a rocket stage is often used and then expended with an orbit that has a high point of many thousands of kilometers and a low point of a few hundred kilometers above the Earth. This particular elongated orbit is called a geosynchronous transfer orbit, and an orbit of this shape is more generally called an elliptical orbit.

Oftentimes, rocket bodies left in these transfer orbits later explode or otherwise disintegrate into debris that travels in roughly the same elliptical orbit. Over time, atmospheric drag at the low point of the orbit gradually drops the high point of the orbit until the debris reenters the Earth's atmosphere. The process can take decades or even centuries, depending on how much drag the object creates.

Figure 3 shows an example of a piece of debris that is in an elliptical orbit and at a different orientation than that of the ISS.

In this elliptical orbit, an object travels quickly when closer to the Earth (for the transfer orbit described above, 35,600 km/h [22,000 miles/h]) and slower when far away from the Earth (for the transfer orbit, 5,700 km/h [3600 miles/h]). In this orbit, it takes 10.5 hours for the object to complete an orbit of the Earth.



**Figure 3.** Conjunction with an object in an elliptical orbit. The ISS travels in a circular orbit at a lower altitude while the debris travels in an elliptical orbit. The lower portion of the debris' orbit can cross the plane of the ISS.

In comparison, the ISS orbits in a nearly circular orbit of 400 km (249 miles) and stays at about 400 km (249 miles) above the Earth as it travels. The velocity is constant at 28,000 km/h (17,300 miles/h), and it takes the ISS 90 minutes to go around the Earth.

The ISS and any given piece of debris will probably never cross paths. With 23,000 large objects being tracked in orbit, however, the ISS typically has a close approach every few days. For the example shown in Figure 3, a close approach would involve the ISS traveling 28,000 km/h (17,300 miles/h), and the debris traveling 35,000 km/h (22,000 miles/h) in a different direction, due to the angle between the orbits. This close approach is called a conjunction. A great deal of effort goes into assessing the risk from this conjunction and protecting the ISS from a catastrophic collision.

## Protecting the International Space Station from Space Debris

The ISS has been shielded for smaller pieces of orbital debris (up to 1 cm [0.4 in.]) and is the most heavily shielded spacecraft ever flown. The shielding generally consists of a metal outer bumper offset from the inner pressure shell, which is also known as a Whipple Shield (see Chapter 3). When debris strikes the outer bumper, the debris vaporizes and dissipates the kinetic energy of the space junk, pitting the bumper but leaving the inner pressure shell intact.

The portions of the ISS most likely to incur a strike are the portions that face forward into the direction of flight when traveling in the normal local vertical/local horizontal attitude. For this reason, the shielding is the highest on the US Segment, which faces into the normal flight direction of the ISS.



Space junk that is marginally above the 1-cm (0.4-in.) capability of the shielding but less than the 10-cm (3.9-in.) threshold that can be ground tracked may cause a penetration of the ISS hull, which can result in an overboard leak and depressurization. The crew has the tools, procedures, and training to arrest such a leak by locating and placing a patch over the interior hull if the hole can be found before the ISS stack pressure drops too low. In the most extreme case, the crew can close off a leaking module by closing the connecting hatches and isolating it, which may cause the loss of the module but would leave the crew members and their escape vehicles safe and intact.

Protection against larger pieces is done by altering the orbit to actively avoiding the debris, as described below.

### **Active Orbital Debris Tracking from the Ground and from Space**

The first step in this protection is the tracking of debris by the US DoD Space Surveillance Network (SSN). The SSN uses radar and optical sensors, both on the ground and in space, that detect and track debris in orbit and build a catalog of objects in space along with their orbital

characteristics. The SSN tracks and updates the orbital location of the debris as the debris changes orbit, due to atmospheric drag, or breaks apart. Figure 4 shows one space-scanning radar complex that is part of the SSN.

Currently, the SSN uses 29 optical and radar sensors to characterize space debris, and makes approximately 400,000 measurements per day. The sensors are divided into dedicated sensors (used exclusively for space surveillance) and contributing/collateral sensors (sometimes used for other purposes).

These sensors are spread around the Earth to better cover possible orbital



**Figure 4.** Millstone/Haystack radar complex used to track orbital debris. The installation is located in Tyngsboro, Massachusetts.



**Figure 5.** Current space SSN sensor locations. Sensors are labeled by the name of the complex in which they are housed, which is sometimes (but not always) geographic location.

locations. Figure 5 shows a map of sensors currently used to maintain the catalog of objects in orbit.

These sensors fall into four categories:

**1) Phased Array Radars:** Radar systems that rely on an electronically steered beam.

- BLE – Beale Air Force Base, California
- COD – Cape Cod Air Force Station, Massachusetts
- CAV – Cavalier Air Force Station, North Dakota
- CLR – Clear Air Force Station, Alaska
- FYL – Fylingdales Royal Air Force Station, North York Moors, England

**2) Mechanical Radars:** Radar systems that rely on a mechanically steered dish.

- ASC – Ascension Royal Air Force Station, Ascension Island
- GBII – Globus II radar station, Vardo, Norway
- MIT/LL – MIT/Lincoln Labs, Massachusetts (includes Millstone and Haystack observatories)
- RTS – Reagan Test Site, Marshall Islands

**3) Ground-based Telescopes:**

- AMOS – Air Force Maui Optical and Supercomputing Site, Maui, Hawaii

Installations of the Ground-based Electro-Optical Deep Space Surveillance system:

- SOC – Socorro, New Mexico
- MAU – Maui, Hawaii
- DGC – Diego Garcia Island

**4) Space-based Optical:** Sensors on satellites in Earth orbit.

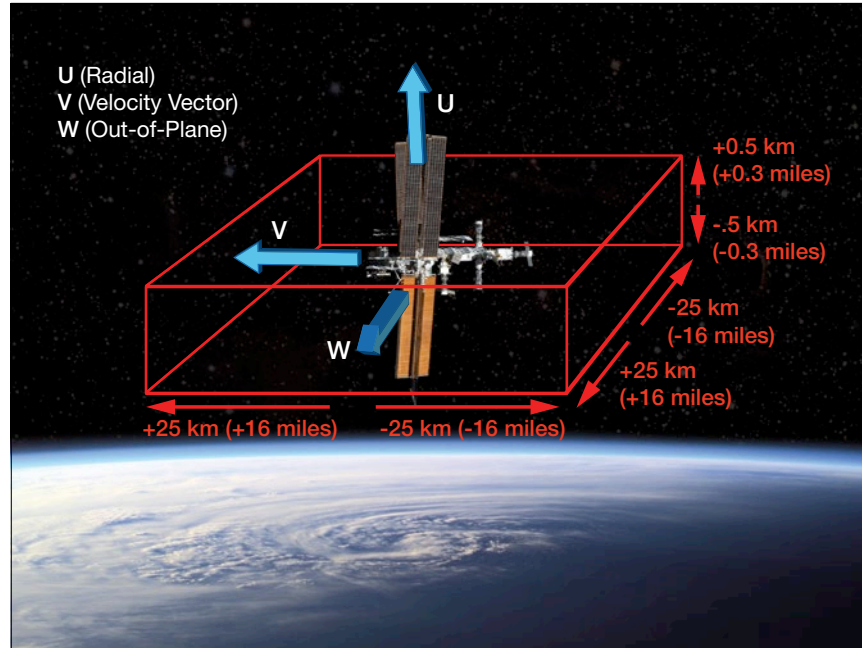
- SBSS – Space-based Space Surveillance, satellite system operated by the US Air Force
- SAPH – Sapphire satellite system operated by the Canadian Armed Forces

## Debris Screening

The DoD Joint Space Operations Center (JSpOC) at Vandenberg Air Force Base, California, performs an assessment of the orbit of the ISS against this catalog of debris every 8 hours. In this assessment, the orbit of the ISS is projected out several days, along with tracked space debris that is orbiting such that it may come close to the ISS. When this assessment predicts a potential close approach between the ISS and a piece of space debris (usually within the following 72 hours), JSpOC will provide data on the close approach, including predicted miss distance and time of closest approach (TCA) to the Trajectory Operations Officer (TOPO) flight controller in Houston.

The TOPO screens an imaginary box of space around the ISS (sometimes referred to as the “pizza box”) that is  $\pm 25$  km ( $\pm 15.5$  miles) in the direction of motion,  $\pm 25$  km ( $\pm 15.5$  miles) perpendicular to the direction of motion, and  $\pm 0.5$  km ( $\pm 0.3$  miles) radially from the ISS as it flies in orbit. This is shown in Figure 6.

If the predicted miss distance is within this box, the TOPO will notify the flight control teams in Houston and Moscow of a potential collision hazard. TOPO will use tracking data on the object and the position of the ISS (see Chapter 7) to calculate a probability of collision ( $P_c$ ) that is a mathematical representation of the likelihood of a collision between the ISS and an object during the close approach. The computation takes into account variables that impact the known orbits of the ISS and the target object, such as uncertainties in atmospheric drag and quality of radar tracks on the target. Just because an object can be detected by radar does



**Figure 6.** The imaginary box (aka the pizza box) around the ISS.

not always mean the precise location can be pinpointed. For example, depending on the size or composition of an object, it might be barely detectable, meaning the radar may get glimpses of an object but not a clear view. The TOPO continuously refines the  $P_c$  of the object as the TCA approaches, iterating up to several times per shift, depending on the level of concern regarding the potential collision.

JSpOC will also work with TOPO and the SSN on increasing coverage on a problem space object to better understand its orbit as required, especially if it becomes a threat to the ISS. Coverage can be increased by using more radars and/or telescopes to gather more data on the object. Coverage can be increased by tracking an object multiple times per day as it passes over various tracking sites when ordinarily it may only be tracked once every few days.

## Evaluating the Risk of a Potential Collision

Flight rules define four levels of concern and actions for orbital debris that will have a close approach and has a calculated  $P_c$ :

- Green:  $P_c$  less than  $10^{-5}$  (less than 1 in 100,000 chance of collision)—no action required.
- Yellow:  $P_c$  between  $10^{-5}$  and  $10^{-4}$  ( $P_c$  greater than 1 in 100,000 but less than 1 in 10,000)—a debris avoidance maneuver (DAM) should be attempted prior to TCA unless there is a major impact to the ISS operations (such as loss of a rendezvous opportunity with a cargo vehicle).
- Red:  $P_c$  between  $10^{-4}$  ( $P_c$  greater than 1 in 10,000) and  $10^{-2}$  (1 in 100)—a DAM should be performed prior to TCA unless the burn itself will place the crew at greater risk. DAMs may also not be

performed during the short 4-orbit rendezvous of Soyuz and Progress, the last 30 hours of the longer Soyuz 34-orbit rendezvous, or the final proximity operations of the Progress 34-orbit rendezvous. This is to protect for cases where the DAM would potentially prevent the rendezvous of the visiting Soyuz/Progress to the ISS.

- Black: Pc greater than  $10^{-2}$  (Pc greater than 1 in 100). A DAM must be performed prior to TCA unless the burn is in the final minutes of a Soyuz or Progress docking operation. This is a brief window of exposure.

The action levels provide a good example of risk management as it appears in flight rules. On a green conjunction, the risk is not zero. Rather, it is reasonably small—1 in 100,000 chance of impact.

Although the risk of collision could be driven closer to zero by moving the green line to, for example, a 1 in 1,000,000 chance, it would also mean the ISS would need to perform far more debris avoidance burns, perhaps even weekly.

Burns of this frequency would be unsupportable. Research on the ISS would be impacted, propellant would be depleted, and the orbit would change so often that some cargo missions would need to be delayed. The threshold chosen represents a balanced and accepted risk where it is as low as possible while still allowing the ISS to be useful as an orbiting laboratory. The yellow—and especially the red and black—thresholds, however, represent unacceptable risk to the crew and ISS, and are where the space station will actively move out of the way of debris.

In the best circumstances, the conjunction is with a well-tracked object and the TOPO will have several days prior to the TCA to calculate multiple updates to the object, refine the Pc, and trend the conjunction. Sometimes, however, an object may be more difficult to predict. For example, a large flat piece of metal from an expended rocket stage in a low orbit has high atmospheric drag in one orientation, and low drag in another. Since it may be tumbling, the drag slowing it down and changing its orbit could vary and makes the TOPO's job more difficult. This is the sort of situation in which additional tracking can help.

As the conjunction nears, the Pc typically gets greener (as described in the next section) with additional tracking and less uncertainty because the orbit of the object becomes better understood and less time will elapse (and introduce prediction error) before the conjunction. For this reason, and because the maneuver can be disruptive to ongoing ISS operations, the general philosophy is to delay a DAM as long as possible to provide the TOPO the opportunity and data to ensure the necessity of that maneuver. In the end, it often comes down to the flight director making the best decision possible by

balancing the impacts and risks per the flight rule, based on the available data and expertise of the TOPO.

## Tracking and Evaluating

Figure 7 shows the trend of a piece of debris (in this case, part of an exploded rocket upper stage) in 2013. The format of the table is exactly the same as that used by the TOPO as he or she works with the SSN to refine the Pc over time.

In the Figure 7 example, data were first provided to MCC-H as an Orbital Conjunction Message (OCM) 68 hours prior to the TCA. Additional OCMs were provided every 4 to 6 hours as JSpOC, the TOPO, and the flight director continued to evaluate the risk posed by the object to the ISS.

The first four OCMs do not include a Pc since several computations over time are required to generate an official Pc to collect data and provide an accurate assessment of the collision risk. As can be seen by examining the miss distances in early OCMs (1-4), the miss distances are changing relatively significantly due to uncertainty in the position of the object.

## Collision Avoidance History

NASA first implemented conjunction assessment on STS-26 in 1988 by using a simple 4 x 10 x 4 km (2.5 x 6.2 x 2.5 mile) football-shaped volume as a “keep out” zone around the Space Shuttle based on simple miss distance, which worked well for the relatively maneuverable shuttle.

Prior to the ISS first element launch in 1998, NASA and the DoD implemented the higher-fidelity risk-based assessment to better understand when a burn was required and to avoid the operational and science impact of performing an unnecessary DAM.

OCM #	TCA (hours)	U (Radial) (km/miles)	V (Downtrack) (km/miles)	W (Cross track) (km/miles)	R (Spacing) (km/miles)	Pc
1	68.9	1.06/0.66	45.90/24.46	-11.41/-7.07	47.31/29.33	
2	62.6	1.02/0.63	43.70/27.09	-10.86/-6.73	45.04/27.92	
3	58.3	-0.57/-0.35	-12.60/-7.81	3.10/1.92	12.99/8.05	
4	54.8	-0.22/-0.14	-1.05/-0.65	0.24/0.15	1.10/0.68	
5	49.8	0.93/0.58	44.48/27.58	-11.07/-6.86	45.85/28.43	2.1x10 <sup>-5</sup>
6	46.4	1.47/0.91	70.57/43.75	-17.55/-10.88	72.74/45.10	1.6x10 <sup>-5</sup>
7	42.0	2.73/1.70	203.32/126.06	-50.56/-31.34	209.53/129.91	0.0x10 <sup>0</sup>
8	38.6	2.73/1.70	210.20/130.32	-52.25/-32.40	216.52/134.24	0.0x10 <sup>0</sup>
9	34.6	2.25/1.40	272.34/168.85	-67.78/-42.02	280.66/174.01	0.0x10 <sup>0</sup>

**Figure 7.** Tracking of a sample conjunction. The information is arranged as follows:

**Column 1:** Orbital Conjunction Message (OCM) number. The OCM is the official message from JSpOC to Mission Control Center-Houston (MCC-H) on an impending potential collision. Multiple messages are generally received on a particular object over time, and are represented by individual rows. In this case, nine messages were received before the object was cleared.

**Column 2:** Time remaining until TCA: The number of hours until the TCA between a tracked object and the ISS.

**Columns 3-5:** Predicted miss distance between the object and the ISS, broken out by axes described in Figure 6.

**Column 6:** Predicted overall miss distance between the object and the ISS.

**Column 7:** Official Pc at the time the message was generated (color coded based on thresholds set in flight rules), as computed by the TOPO in MCC-H.

During this time period, the TOPO and JSpOC often work together to devote more observation time and assets of the network to help refine the understanding of the location and velocity of the object as it orbits the Earth, which is reflected in the later OCMs.

When an official Pc was determined, it was for a yellow conjunction at 49.5 hours before TCA on OCM 5.

Yellow conjunctions can eventually result in a DAM if an object stays yellow closer to TCA; however, in general, additional tracking and reduction in uncertainty often clears an object. In this case, the Pc was calculated as zero and the object went green 42 hours prior to TCA.

Unfortunately, some conjunctions stay yellow or become red as more tracking becomes available. Debris

that has high atmospheric drag or is in an unusual orbit (such as a highly elliptical orbit) is less predictable, and some collision threats are not identified until late (less than a day before TCA). Figure 8 shows a conjunction that began as green and eventually developed into enough of a threat to require a DAM.

In these cases, a DAM is planned and, if necessary, executed.

OCM #	TCA (hours)	U (Radial) (km/miles)	V (Downtrack) (km/miles)	W (Cross track) (km/miles)	R (Spacing) (km/miles)	Pc
1	69.3	-0.19/-0.12	-7.26/-4.51	-9.93/-6.17	12.30/7.64	2.610 <sup>-9</sup>
2	60.9	-0.18/-0.11	-11.28/-7.10	-15.41/-9.58	19.09/11.86	7.510 <sup>-7</sup>
3	53.1	-0.18/-0.11	-2.55/-1.58	-3.48/-2.16	4.32/2.68	1.410 <sup>-6</sup>
4	45.3	-0.22/-0.14	-1.33/-0.83	-1.82/-1.13	2.26/1.40	5.510 <sup>-13</sup>
5	37.5	-0.32/-0.20	6.68/4.15	9.13/5.78	11.32/7.03	7.0x10 <sup>-17</sup>
6	29.0	-0.14/-0.09	2.95/1.83	4.04/2.51	5.00/3.11	6.3x10 <sup>-5</sup>
7	21.4	-0.07/-0.04	-0.72/-0.45	-0.98/-0.61	1.22/0.76	1.1x10 <sup>-3</sup>
8	12.8	-0.16/-0.10	2.30/1.43	3.15/1.96	3.90/2.42	7.6x10 <sup>-5</sup>
9	11.4	-0.09/-0.06	-0.88/-0.55	-1.19/-0.74	1.48/0.92	2.5x10 <sup>-3</sup>
10	9.8	-0.04/-0.03	-0.04/-0.03	-0.05/-0.03	0.08/0.05	1.310 <sup>-2</sup>
11	5.1	-0.01/-0.01	-0.66/-0.41	-0.91/-0.66	1.12/0.70	1.710 <sup>-2</sup>

**Figure 8.** Development of a conjunction, which requires a maneuver. See Figure 7 for data definitions.

## Debris Avoidance Maneuvers

DAMs are planned as a small orbital-raising (or reboost) maneuver.

A reboost maneuver uses the small rocket thrusters on the aft of the ISS to push it slightly higher in orbit. The ISS is designed such that all propulsion is done by the Russian Segment. The core of the propulsion system is the Service Module, which is operationally controlled by Mission Control Center-Moscow (MCC-M). Small thrusters on the Progress resupply vehicles can be used for both reboost and attitude control, depending on the specific docking ports, whereas the propulsion system is under the control of MCC-M, the Service Module, and the Service Module computers.

Although MCC-M actually controls and fires the rockets, MCC-H provides threat assessments based on JSpOC data. The control centers work together to keep the ISS in the correct orbit.

Reboost maneuvers are already periodically scheduled to raise the orbit of the ISS, which decays naturally due to atmospheric drag. A DAM is the same thing, but is planned with flexibility in mind so the maneuvers can be executed in only a few hours, if necessary.

DAM reboosts are relatively small. A DAM performed in 2012 fired the Service Module engines for 54 seconds, which raised the altitude of the ISS by 1.5 km (0.9 miles). This “nudge” in the orbit is all that is required to clear a conjunction successfully and carry the ISS away from the future

potential impact. These nudges are usually targeted to occur 2 hours and 20 minutes prior to a potential impact, which provides sufficient time in the new orbit to travel away from the point of collision before the close approach occurs.

When the need to at least plan for a debris avoidance burn becomes apparent (typically ~30 hours before TCA for a conjunction that is not improving), the TOPO along with his or her counterparts at MCC-M will plan a DAM burn. The burn will be optimized to minimize the impact on the ISS operations (for example, if possible, to avoid periods where feathering the solar arrays and a power down would present a power challenge), to minimize impact to downstream planning of vehicles that will be docking to the space station or returning to Earth from the ISS in the coming months, and finally to place the ISS on a new trajectory that has been preemptively evaluated by JSpOC as clear and free of debris (at least for the next several days).

Detailed execution planning is handed to MCC-M as soon as the TOPO has designed a DAM consisting of a specific burn magnitude, duration, and time. Engineers at MCC-M will build a software script that allows the computers in the Service Module to physically execute the burn. This script is referred to by its Russian moniker: cyclogram.

The Russian software executes a series of cyclogram-defined commands on the Russian Segment automatically. Russian flight controllers at MCC-M will build the cyclogram on the ground, verify by running it on a software test bed

with the same computers used on the space station, and uploading it for use on the actual reboost. It takes a day to complete this process if the cyclogram is being built from scratch.

The cyclogram contains detailed commands that begin execution approximately 90 minutes prior to a debris avoidance burn, immediately after attitude control is handed over from the US Segment to the Russian Segment. The cyclogram will then configure the propulsion system to fire thrusters, maneuver the ISS to the reboost attitude (i.e., aim the main engines so that the thrust will increase the orbital altitude), and fire the engines at the appropriate time and for the appropriate duration. After the burn ends, flight controllers at MCC-M and MCC-H will work together to hand attitude control back over to its normal long-term configuration using the US Segment Control Moment Gyroscopes (CMGs).

There are two kinds of DAMs—a standard DAM and a predetermined DAM (PDAM)—each with its own cyclogram.

A standard DAM is essentially identical to a planned reboost except that MCC-H builds the software load on an expedited schedule. Normal reboosts to counter atmospheric drag or to set up phasing for a visiting vehicle are calculated months in advance. A standard DAM requires approximately 24 hours to build and verify, but it has greater flexibility for selecting burn duration and choosing the vehicle that will conduct the reboost. For example, the Service Module itself can perform a reboost if a Progress is not docked to the aft of the Service Module or Docking

Compartment-1 on the bottom of the ISS (which requires an attitude maneuver to point the Progress engines in the correct direction).

A standard DAM also allows MCC-M and MCC-H to custom pick the burn duration to change the orbit velocity (also referred to as the delta-V). This can be helpful when shaping the orbit to account for where the ISS needs to rendezvous, and to undock cargo and crew delivery vehicles that are planned over the next few months.

A PDAM is a “canned” burn plan with limited delta V options that is always ready and loaded in the Russian Segment. The PDAM is a capability that was first made available in 2012. Prior to that time, all DAMs were standard DAMs. The PDAM was developed in response to the increasing number of conjunctions that were occurring (due to the increase of orbital debris over the past decade) as well as the development time required for the standard DAM. Prior to the development of the PDAM capability, if a conjunction was detected between the ISS and a piece of debris within approximately 24 hours, there was insufficient time to develop a cyclogram and maneuver the ISS out of the way. The crew and flight control team were left with simply isolating the crew members in their Soyuz vehicles as protection from the effects of an impact.

PDAMs are pre-developed plans that permanently reside in the Service Module software and have burns available of 0.3, 0.5, 0.7, or 1.0 m/s (1.0, 1.6, 2.3 or 3.3 ft/s). MCC-H and MCC-M can select a burn magnitude that will best change the orbit to avoid a conjunction as well as keep

the ISS in the proper position for later operations, such as rendezvous of crew and cargo vehicles that are weeks or months away. It is also possible that one burn magnitude may clear the ISS out of the path of the original debris, only to find it in the path of some other object. Having four options ensures that one solution can be found that will clear the path of all debris.

Because a PDAM is already built and on board the space station computers, a PDAM can be planned and executed with as few as 5.5 hours remaining until a conjunction will occur. The 5.5-hour minimum is driven by the time required to configure the solar arrays (3 hours) prior to the avoidance burn, which is typically done 2 hours and 20 minutes prior to the closest approach. The solar arrays need to be positioned in specific orientations to avoid being struck by the exhaust of the thrusters that are used for both the reboost and the attitude control. The 2-hour-and-20-minute burn point is driven by the need to travel for a short period of time in the new, slightly adjusted orbit to move away from the conjunction.

Because the PDAM can be executed rapidly and cancelled late, and because most conjunctions become green as the time before closest approach decreases, the preferred strategy for debris avoidance is usually to wait out the conjunction and plan to do a PDAM at the latest possible time, if it is still required.

The only downside to this strategy is that the burn magnitudes are limited to those in the canned burns. In some cases, MCC-H and MCC-M may

elect to plan for a standard burn if a more tailored reboost would be beneficial from a trajectory point of view to preserve, for example, a particular rendezvous opportunity several weeks away.

## **Predetermined Debris Avoidance Maneuver Execution**

When a space debris threat continues to be yellow or red with less than 24 hours remaining to TCA, or when JSpOC notifies MCC-H of a late-notice conjunction, PDAM planning goes into high gear to prepare the ISS for an escape maneuver. As previously discussed, the TOPO will select a candidate burn time (usually 2 hours and 20 minutes prior to TCA), and the MCC-H flight director will approve the time and direct teams to plan for a burn.

This planning will attempt to configure the space station systems (especially power and payload) as gracefully as possible based on how much time is available before the burn executes. Most of this planning centers around power availability, since (as in many thruster firings) the solar arrays are repositioned to best protect them from thruster firings rather than optimized for power generation. Generally, this means less power is available than had originally been planned and certain systems need to be turned off. With careful planning, certain allowances can be made—for example, an experiment that requires a few more hours to finish will be allowed to complete before being turned off. The more

advanced warning available, the more time flight controllers have to work the intricate details of this power-down plan.

When necessary, however, the ISS can execute a burn with as little as 3 hours' notice (about 5 hours

and 20 minutes before the conjunction if the burn is done at the standard 2 hours and 20 minutes). An emergency unplanned power down is normally required in order to perform a burn this quickly. This power down is a preplanned power

down, which is always available but unrefined, and may result in noncritical systems being powered down rapidly, thus potentially impacting research on board. For this reason, the emergency power down is an option of last resort.

Time	Event	Comments
Pre-burn	Request additional Tracking and Data Relay Satellite (TDRS) time from space network	If necessary, MCC-H will request to fill gaps in TDRS satellite coverage of the ISS to provide command and telemetry links during critical periods leading up to the PDAM burn as well as the burn itself.  TDRS satellite coverage is usually quite good, but there are often 10- to 30-minute gaps in coverage while the satellite network is shared with other users. These gaps can often be negotiated with other users and filled to provide more time for MCC-H and MCC-M to command configurations in preparation for the reboost.
Pre-burn	Safe payload racks and other vehicle systems	Certain payload and vehicle systems are sensitive to thruster firings (for example, the treadmill needs to be fixed to the ISS structure and not in use during reboost burns).
TIG – 2:40	ISS power down	Power down the ISS systems to support the feathering of solar arrays.
TIG – 2:40	Generate burn options	If not already done, TOPO generates burn options and supply to JSpOC for debris screening and provides options to MCC-M.
TIG – 2:25	Power up redundant navigation equipment	MCC-H powers up redundant rate gyro assemblies and enables US Segment accelerometers to support burn.  Redundant gyros are brought up to protect against failures during the burn (in some cases, the burn may stop without the redundant equipment). The accelerometers in the US Segment are used by the Russian Segment to calculate the end of the burn.
TIG – 2:25	Park and lock solar array joints	Position solar arrays for propulsive support and reboost. Solar arrays are usually positioned in a way that minimizes the structural effects caused by thruster firings.
TIG – 1:30	Select final burn option	If not already done, TOPO selects and approves the final burn time based on JSpOC screening and provides the final burn option to MCC-M.
TIG -1:30	Final go/no go for PDAM	The MCC-H and MCC-M flight directors authorize execution of the debris avoidance burn.
TIG – 1:20	MCC-H commanded handover of attitude control to the Russian Segment	MCC-H commands attitude control to handover from United States On-orbit Segment (USOS) non-propulsive CMG attitude control to Russian Segment thrusters attitude control.
TIG – 1:00	MCC-M commands burn execution sequence initialization	MCC-M will issue a command to begin the automatic burn sequence. This sequence will configure systems on the Russian Segment (including the propulsion and attitude control systems), maneuver the stack to burn attitude, and then execute the burn exactly 1 hour after the command is received.
TIG	Burn execution	Under Russian Segment Service Module automatic control, several minutes in duration depending on configuration of propulsion system and engines used. The ISS is maneuvered back to attitude post burn.
TIG + 00:40	MCC-H commanded handover back to the USOS	MCC-H commands attitude control back to USOS non-propulsive CMG attitude control.
Post-burn	Clean up	MCC-H places solar arrays back in solar auto track to maximize power generation and repowers systems to restore normal operations.



The following timeline is based on the time of ignition (TIG)—the time at which the PDAM burn would execute. Throughout the PDAM planning and execution process, TOPO continues to refine the Pc calculation as data from JSpOC become available. If an object manages to go green very late, the burn can be cancelled. Typically, this occurs before the final attitude control handover to avoid thruster firings, which may perturb the orbit (and potentially increase the probability of collision).

### Safe Haven

If MCC-H is notified of a conjunction very late, there may not be enough time to execute a burn. As mentioned previously, MCC-H and MCC-M must be notified no later than 5.5 hours before the TCA to configure the systems (primarily solar arrays), start the burn sequence on board the Russian Segment, and actually perform the burn.

If insufficient time is available, “safe haven” procedures allow the ISS crew members to close hatches in the USOS, enter their respective Soyuz vehicles (which are used to transport crews to and from the ISS), and close the hatches in the Soyuz to be best set up for withstanding an impact and performing an emergency departure and deorbit, if required. Keeping hatches closed ensures that if a module is penetrated by an impact event, the loss of air is limited to that module and not the entire ISS volume. Keeping the

crew members inside the Soyuz minimizes their exposure to an ISS depressurization that results from impact and has them pre-positioned in the vehicle that can return them home if the ISS is significantly damaged.

Safe haven was executed on several occasions earlier in the life of the ISS before the advent of PDAM, when only the nominal DAM was available and required a 24-hour notice. PDAM was developed specifically to avoid the safe haven scenario and has been largely successful, since notification of a conjunction by JSpOC with less than 6 hours remaining is extremely unusual.

### Frequency of the International Space Station Debris Avoidance Maneuvers

As of mid-2016, DAMs have been attempted 21 times (the first one in 1999 was unsuccessful and did not burn). Further safe haven events (in 2009, 2011, 2012, and 2015) have taken place, three of which occurred prior to the creation of the PDAM in 2012, which made them less likely. For comparison’s sake, in 2015, 116 conjunctions fell within the pizza box. MCC-H actively worked these conjunctions, 111 of which eventually went green and did not require a DAM or PDAM. An actual impact with a tracked object, which would result in (at a minimum) significant damage to the ISS, has never occurred. Figure 9 shows the number of DAMs.

Year	# DAM
2017	0
2016	0
2015	4
2014	5
2013	0
2012	3
2011	2
2010	1
2009	2
2008	1
2004-2007	0
2003	1
2002	1
2001	2
2000	1
1999	2
1998	0

Figure 9. DAMs by year through mid-2017.

### The Orbital Debris Environment—A Growing Problem

The debris environment in the vicinity of the ISS has gotten worse over the past 15 years. According to the NASA Orbital Debris Office, more than one-third of the debris currently in orbit came from two events: the hypervelocity collision between the operational Iridium 33 satellite and the abandoned Kosmos 2251 satellite in 2009, recounted above; and, the intentional destruction of the Fengyun-1C weather satellite by China in 2007 with a missile during a defense test. The collision between Kosmos and Iridium alone produced more than 2000 pieces of trackable debris.

## A Close Call

### Captain Daniel C. Burbank, Expedition 30

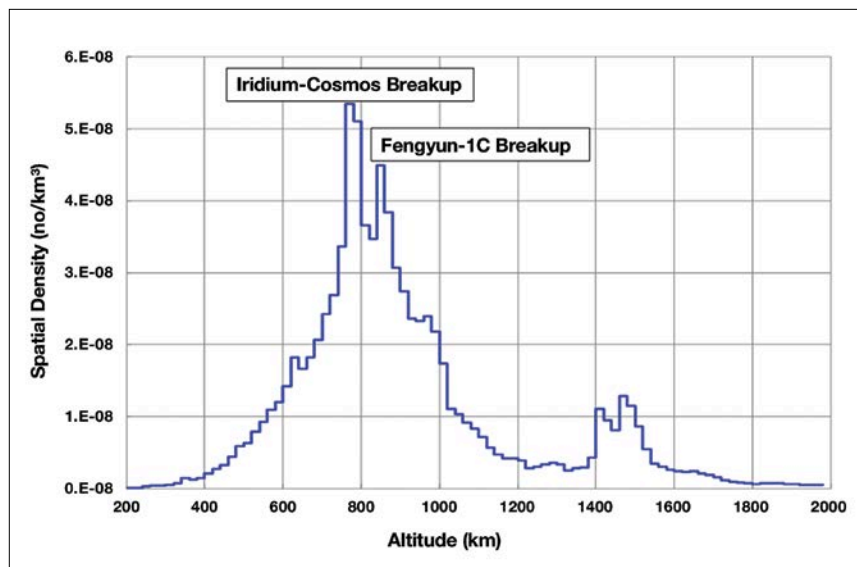
Orbital debris penetrating the hull of our spacecraft is one of the “Big 3” threats that astronauts and flight directors worry about the most—along with fire and a toxic atmosphere. Orbital debris is a particularly insidious threat because there are hundreds of thousands of chunks of debris traveling around the Earth at enormous velocity, and most are too small to track with radar. Because of this, we essentially fly spacecraft in low-Earth orbit—in what pilots might euphemistically refer to as the “big sky, little airplane” theory of operation—where the likelihood of running into something is statistically extremely low. The difference between flying airplanes and flying spaceships is that things move MUCH faster in space than they do in the air, meaning the kinetic energy is exponentially higher. Something traveling in low-Earth orbit at a typical 28,000 km/hr (17,500 miles/hr) might travel at 100 times the speed of an airplane flying at 282 km/hr (175 miles/hr), but its energy (per given kilogram of mass) is 10,000 times greater. Although the

odds are low that we will hit anything, the consequences of doing so are therefore potentially catastrophic.

The call came up from Houston late in the evening on Friday, March 23, 2012, that JSpOC was tracking a late-notice conjunction—space jargon for a short-notice potential impact from orbital debris. The TCA was early the next morning. This hunk of debris was left over from a 2009 collision between an out-of-service Russian Kosmos satellite and an Iridium communication satellite. It was “draggy” (not very dense), thereby making its trajectory difficult to predict and track, which further limited the prediction accuracy. The way conjunctions usually work is that they are identified well in advance and, even if they start out red (high risk and/or high uncertainty), they gradually become yellow (moderate risk) and then green (essentially no risk) as the trajectories are refined. Even when they don’t turn green, the ground usually has plenty of time to plan an ISS or Progress engine burn, called a DAM, and nudge the space station away from the impending impact (this was before the Russian and American programs were able to implement the quicker PDAM process). In this case, the uncertainty stayed high and the exceptionally late notice

Much of the debris from these events is actually above the altitude of the ISS. Figure 10 shows the density (number) of tracked objects present in a cubic kilometer of space at a given altitude. As is shown in Figure 10, the highest density of debris is at approximately 800 km (500 miles) altitude, and was the result of the Iridium and Fengyun events.

Although the bulk of this debris is above the ISS orbit, it will descend over time due to atmospheric drag, and the number of conjunctions with the space station will increase. For these reasons, the flight control team continues to refine its tools available to assess and protect against threats from orbital debris.



**Figure 10.** Low-Earth orbit debris density (from <http://www.unoosa.org/pdf/pres/stsc2011/tech-31.pdf>, NASA report). The y-axis displays the density of objects in terms of number of objects per cubic kilometer while the x-axis shows the altitude. The collision between the Iridium and Cosmos satellite lead to a peak of about  $5.5 \times 10^{-8}$  particles per cubic kilometer at an altitude around 800 km (500 miles).

of the conjunction meant it would have been impossible to push the ISS out of harm's way. This has happened only four times during 18-year lifetime of the ISS.

So, in this case, Houston gave us the order early morning Saturday to configure the ISS for possible impact and subsequent abandonment. We were told to power down all the nonessential equipment, close the hatches between the various modules, shut down the intramodule ventilation, and then take shelter in our respective Soyuz spacecraft. The TCA was 6:38 a.m. The ground uplinked a "late-notice conjunction/safe haven actions" procedure that would guide us through the power downs and module isolation and tuck us safely away in our Soyuz spacecraft, ready to abandon ship, if necessary. This was an all-hands-on-deck effort where all six of the ISS crew members worked in tight coordination with the MCC flight controllers to save the ISS. By closing the hatches between the modules, we gave the crews and MCCs a fighting chance of recovering the ISS by isolating any breached modules from the rest of the ISS volume. Compartmentalization is how the sailors and submariners refer to this, where damage to one portion of a ship is prevented from

threatening other portions by keeping water-tight hatches secured. In our case, we weren't worried about water coming in, but rather air going out.

By 5:00 a.m., we started working the isolation/safe haven procedures beginning at the forward-most part of the ISS, carefully working our way aft toward the Soyuz spacecraft. One of the last things we did before entering our respective spacecraft and closing the hatches was to configure the ISS communication system for emergency mode, which would enable communication between the ground and the two Soyuz spacecraft. By 6:00 a.m., Anton [Shkaplerov], Anatoly [Ivanishin], and I were in our Soyuz and Don [Pettit], Andre [Kuipers], and Oleg [Kononenko] were in their Soyuz. We partially closed (to soft dock) our Soyuz hatches and then all sat quietly and waited for either a loud boom or [hopefully] the "all clear" call from Houston. Thankfully, 6:38:33 a.m. passed uneventfully and the ISS and its menacing interloper passed each other at a comfortable 16.5 km (10.2 miles) miss distance. We all floated out of our spacecraft, reconfigured the ISS hatches and systems, and enjoyed many more weeks of life and work aboard the ISS.

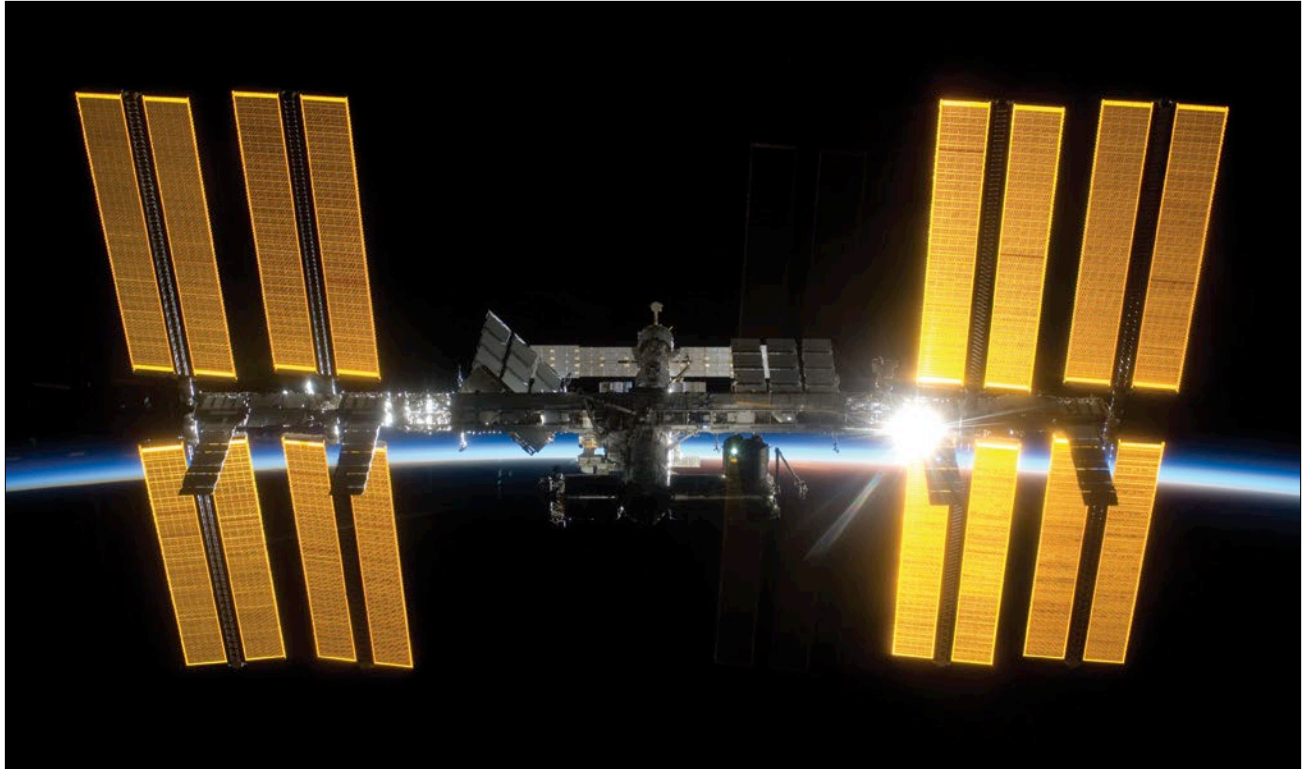
## Conclusion

Despite a debris environment that has become more hostile over the decade and a half that ISS has been in orbit, Mission Control, NASA researchers, and JSpOC have correspondingly improved tools to protect the ISS and its crew. They have crafted methods that better track debris and characterize the threat from an identified conjunction with debris, and developed operational responses to help the ISS move into a safer orbit, rapidly, and avoid maneuvers unless absolutely required.

As the population of debris in low-Earth orbit continues to worsen, these tools will continue to be refined to keep the ISS a safe and operationally useful laboratory.



# Chapter 9 **Systems:** Electrical Power System—The Power Behind It All



*International Space Station solar arrays capture sunlight during STS-119/ISS-15A fly around.*

**“Following the light of the sun,  
we left the Old World.”**

**– Christopher Columbus**

Electrical power is the lifeblood of the International Space Station (ISS). Literally, it is the energy that keeps the ISS running. The ISS uses electrical power to operate the various systems that ultimately allow crew members residing on the space station and scientists across the globe to perform world-class research. In turn, the Electrical Power System (EPS) relies on those systems to provide command and control, to cool EPS devices, and to pinpoint the location of the sun to harvest its energy.

Previous NASA human spacecraft relied on consumables-based energy systems. Fuel cells used hydrogen and oxygen to produce power and,

as a side benefit, water. This worked well for short-duration missions. For the long-duration mission of the ISS, resupplying these consumables would be cost prohibitive and would endanger the future of ISS operations, should the resupply be interrupted. Solar arrays and cells, along with batteries, proved to be viable power sources for satellites and were used in the Russian human space program—including the Mir space station. However, the energy demands of the ISS would require the largest solar power system ever (to date) to be designed, built on Earth, assembled in orbit, and operationally maintained for decades.

Many design decisions drove the overall architecture and operations of the EPS early in the development of the ISS. Large design differences

exist between the Russian Segment (RS) and United States On-orbit Segment (USOS), though they have the capability to transfer power to each other. Even the voltage at which the EPS operates has large impacts on hardware design and actions necessary for crew and ISS safety. Multiple independent power sources provide redundancy for critical systems and allow power to be rerouted in the event of a failure.

The USOS EPS can be divided and discussed in many ways, but it may be easiest to compare it to how most homes on Earth receive electrical power. Similar to terrestrial power plants, the Primary Power System, operating at high voltage, is where solar energy is converted to electrical power and stored in batteries for use during eclipse. A combination of

mechanical joints are used to rotate the solar arrays and even entire truss elements to keep the large USOS solar arrays pointed at the sun. Similar to how transformers on utility poles near homes work, power is then converted to lower voltage in the Secondary Power System for use by end-user devices, or “loads,” such as computers and fans. A series of cables and power distribution units move power throughout the EPS and ultimately to users, as with high-tension power lines, buried cables, and even wiring inside homes. Finally, the EPS contains specific loads that support overall operations on board the ISS, including lights, switches, and extension cords.

In summary, the ISS solar arrays collect power during insolation, when the ISS is not in the shadow of the Earth. This power is supplied to equipment throughout the ISS and charges batteries for use during eclipse, when the Earth shadows the ISS from the sun. Power flows through various distribution control devices and switches to reach end-user loads.

This chapter will discuss the hardware and process of converting sunlight into useable power and safely distributing it throughout the space station. Although many power systems used on the ISS are similar to those in terrestrial electrical networks and homes, the need for redundancy and the ability to be operated from far away in Mission Control require a number of critical design choices. The massive solar arrays on the ISS demand a great deal of interaction by the flight control team due to a number of constraints on the solar array operations, many of which were imposed after their design, including when and how other vehicles can dock.

## **Background: Design Decisions**

### ***Distributed vs. Non-distributed Electrical Power System***

The first ISS modules were designed with non-distributed EPSs. This means each module has a self-contained EPS that is able to generate, store, and distribute electrical power. Each module has its own solar arrays, batteries, distribution network, switches, etc. This structure was essential for early space station modules so that they could be essentially turnkey after launch, thus not requiring assembly or crew tending on orbit. The Russian Functional Cargo Block (FGB) and Service Module (SM) are based on designs used for the Mir space station, where non-distributed EPSs worked well. However, having each module outfitted with its own EPS adds mass, complexity, maintenance, and overall cost. As the ISS grew, new modules would potentially shadow the solar arrays of other modules, thereby causing loss of necessary power generation. In fact, deployment of the External Thermal Control System (ETCS) radiators (see Chapter 11) on the P1 and S1 truss segments physically interfered with the FGB solar array rotational envelope. This required the FGB solar arrays to be retracted, which greatly reduced their power-generation capabilities. The FGB then became dependent on power transfer from the USOS.

The USOS EPS and later RS modules were designed using a distributed EPS. Power is generated and stored by specifically designed power modules and then distributed to the rest of the ISS where it is needed. Having dedicated power modules reduces the mass required by having replicated

power systems such as batteries and converters for each module. However, this warrants much larger solar arrays and batteries to meet the power demands of the ISS. These large solar arrays were placed farther from other modules, which allowed the arrays to be positioned to see the sun and avoid sunlight blockage from other modules. The design trade was that it would take multiple Space Shuttle missions over the course of years until the USOS Primary Power System would be fully assembled. This meant full capability and redundancy was not available until well into ISS assembly, which resulted in a limiting effect on the amount of science conducted on the ISS early in its lifetime. Additionally, this caused many changes in procedures and training for ground controllers and crew. Almost constant work was required to keep the operations team in sync with the current configuration.

### ***Current, Voltage, and Mass***

Going back to the beginning of the earliest uses of electrical power, arguments took place over the benefits and detriments between alternating current (AC) and direct current (DC). In the 1880s, this became a famous “battle” between Thomas Edison (promoting DC) and George Westinghouse, who held patents to Nikola Tesla’s work with AC. Terrestrially, AC won out due to cost and efficiency, with the United States using a 110 Volt AC system and the European standard 220 Volt AC. However, solar array and battery system designs naturally generate and store energy using DC. In fact, 28 Volt DC systems have become an aerospace industry standard. However, it can be difficult to efficiently change the voltage in a DC system; and, as will be discussed later, the ISS

DC-to-DC Converter Units (DDCUs) actually make use of AC to change voltage levels. The ISS also uses DC-to-AC inverters to provide US standard 110 Volt AC power to user loads in an effort to reduce cost and make use of commercial off-the-shelf (COTS) equipment.

As mentioned above, 28 Volt DC systems have become an aerospace standard, and this standard was used for the RS EPS. However, low-voltage DC systems require higher currents and therefore larger, heavier cables to meet user power demand. To reduce mass, especially in a distributed power system, the USOS was designed to use higher voltages, which would require lower currents and smaller cables. The USOS uses an approximately 160 Volt DC primary and an approximately 124 Volt DC secondary system. Although this accomplished the goal of allowing smaller cabling to reduce mass, it also resulted in a few design impacts. As a new standard, user equipment had to be designed to either use the higher voltage or require additional support hardware in the form of power converters and inverters. Additionally, the higher voltage poses safety risks to both the hardware and the crew. Higher voltage presents a greater chance of electrical arcs, which could potentially cause damage to connections that are being mated (connected) or demated (disconnected). One result of this damage could be the release of molten metal, which might penetrate a spacesuit or cause physical harm to the crew in microgravity. Additionally, the higher voltage increases the electrical shock risk to the crew member when working with electrical connections. Therefore, safety requirements call for multiple levels of inhibits (i.e., steps to prevent electrical current flow, such as adding an open

switch) to prevent exposing the crew and hardware to this high-voltage potential during electrical connector operations. Operationally, this requires removing power at higher levels, or “upstream,” in the EPS architecture and therefore powering down multiple pieces of equipment to replace one device. To relate this to the average home, it would be comparable to requiring the resident to turn off the room circuit breaker as well as the light switch when replacing a light bulb. Although this many levels provide additional protection against arcing and shock, it can add risk by unpowering perfectly good devices and removing redundancy.

### ***Trip Coordination***

Another overall design aspect of the EPS is current trip coordination. This is called a “safing function” because it places the hardware in a safe (unpowered) configuration while also trying to preserve as much functionality when faced with a malfunctioning piece of equipment. Electrical current sensors throughout the EPS monitor and report the amount of current flowing between electrical devices. When one of these sensors detects a higher-than-expected current, automated actions called “trips” are taken to open switches or deactivate equipment to remove the potentially hazardous situation. Usually, the higher current is caused by an electrical short (e.g., electrical wires crossed or touching) in the hardware and could lead to an electrical fire if left uncorrected. This is identical to a fuse or circuit breaker in a house activating and removing power when too many devices are connected to one electrical socket or when one device has become damaged. Trips need to be fast—on the order of microseconds

or milliseconds—to protect hardware and cabling from damage. If a lower-level device did not trip fast enough, the higher current draw would be seen by higher-level devices. If the high-level device trips, power would be removed from more equipment than necessary. Therefore, the trip times are fastest at the lowest levels and lengthen higher in the EPS architecture. However, some devices on the ISS (e.g., motors on larger pumps) have startup transients that require additional current for short durations. This additional current may be enough to trigger the EPS trip functions. Some EPS devices were designed to “current limit” prior to tripping to handle these situations, where necessary. Current limiting is a function where an EPS device can actually adjust both output voltage and current so that, on average, the level is safe in an attempt to manage total output power. Limiting the current prevents upstream EPS devices from seeing higher current draws, thus preventing trips, while allowing a short time for device startup transients. Usually, the current is limited for only hundredths of seconds. If the transient has not ended in that time, the trip function will remove power from “downstream” load(s).

### ***Remote Control***

A design goal of the ISS was to make as many systems as possible remote controllable. Although this created the need for a robust Command and Data Handling system (see Chapter 5), it allowed for mass savings (i.e., less physical switches) and overall control from the ground for times when the crew was not available. In turn, this allowed the crew to focus on scientific research instead of day-to-day ISS operations. Most USOS EPS devices have firmware

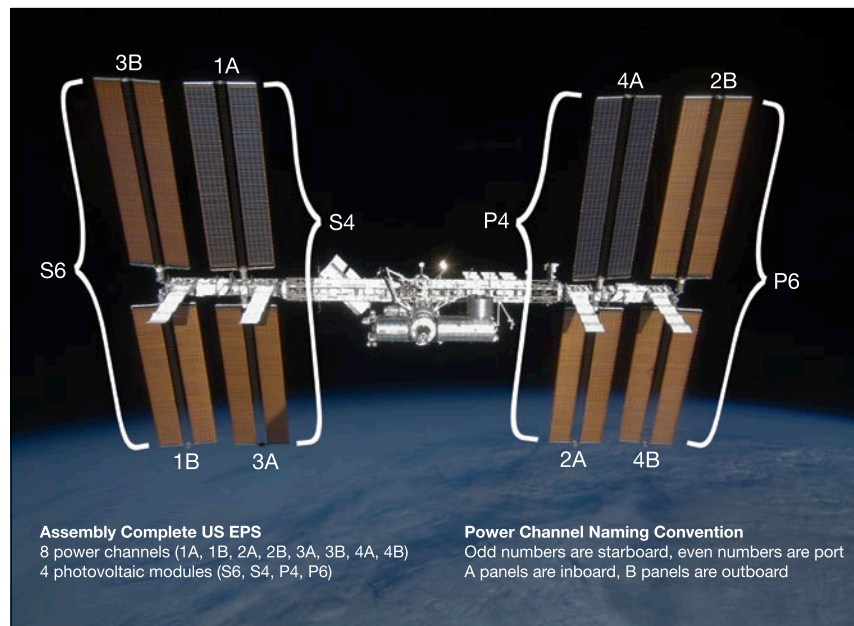


controllers (small computers) that interface with the Command and Data Handling system to provide data and receive commands. These firmware controllers monitor current, voltage, and temperature sensors to provide insight into the health and function of the EPS. They also respond to commands from ground controllers, crew members, or automated software functions on board. These commands can open or close switches, turn automated functions on or off, or change the modes or set points that manage EPS operations. One downside is that the system had an increased dependence on computers to safe hardware. This is especially evident when certain computers control their own power switches. If one of those computers malfunctions, it may be necessary to go farther upstream in the EPS to remove power from the faulty computer, thus impacting other user loads. In fact, a significant part of a module may need to be powered down to change out the faulty computer. Although remote-control capabilities have proven beneficial for freeing up crew time and potentially saving the ISS if a crew is not available to respond to off-nominal situations, having practically no manual overrides in the EPS also has its detriments.

## System Overview

### Power Channels

The USOS EPS is divided into eight power channels: 1A, 1B, 2A, 2B, 3A, 3B, 4A, and 4B. A power channel contains the equipment necessary to generate, store, and distribute power as an independent source. It also contains support equipment for command and control, cooling, and



**Figure 1.** ISS PVMs and power channels.

solar array pointing to keep the power channel functioning. The primary power equipment responsible for generating and storing electrical power is located on four Photo-Voltaic Modules (PVMs): the P4, P6, S4, and S6 truss segments. Each PVM supports two power channels. Hardware for channels 1 and 3 is located on the starboard truss; hardware for channels 2 and 4 is located on the port truss. The two fully independent and redundant power channels are labeled A and B. Channel A runs on S4 and P4, whereas B is connected to S6 and P6 (Figure 1).

A subset of power channels—1A, 1B, and 2B—are considered to be the core power channels. These channels provide power to some of the most important space station systems hardware such as critical avionics (e.g., computers and communications equipment), life support systems, and external and internal Thermal Control Systems. These core channels and the concept of electrical power domains

greatly impact how redundancy of critical systems was designed and is maintained on the ISS. Operationally, it is important to note that these critical systems are unevenly distributed across these core channels. Channel 1A supports ETCS Loop A, while channel 1B powers one string of critical avionics. However, channel 2B alone supports ETCS Loop B and one string of critical avionics. Due to this uneven distribution, loading on channel 2B is higher than the other core channels and takes more planning to keep it within energy balance when the ISS is in a power-constrained configuration, such as one that occurs during vehicle dockings (e.g., requiring a solar array to be in a fixed position).

### Domains and Redundancy

Even with the best designs, ISS hardware and systems can wear out and fail. Critical systems have backups and sometimes multiple backups to keep the space station

safe and functioning, should such an event occur. Generically, the concept of providing backup capabilities is called “redundancy.” Redundancy can be implemented by having multiple systems that perform the same function, such as multiple radios or computers. For less-critical functions, redundancy might mean having one system that can be powered from different sources.

When designing the overall redundancy of the ISS, engineers defined the USOS EPS as separated into two domains: the 1/4 domain and the 2/3 domain. The 1/4 domain is made up of power channels 1A, 1B, 4A, and 4B; the 2/3 domain consists of power channels 2A, 2B, 3A, and 3B. As noted above, critical ISS systems are split between channels 1A and 1B on the 1/4 domain and channel 2B on the 2/3 domain. However, not only are critical loads split between these domains, so are auxiliary and payload equipment. Two physical features define the power domains: cooling of associated EPS devices by different ETCS loops, and the placement of associated core power channels on opposite sides of the ISS (i.e., port and starboard). The ETCS Loop A, while powered by the 1/4 domain, provides cooling for critical 1/4 domain EPS hardware. Similarly, the ETCS Loop B, while powered by the 2/3 domain, provides cooling for critical 2/3 domain EPS hardware. Placing the core power channels on opposite sides of the ISS eliminates reliance of those channels on the same Solar Alpha Rotary Joint (SARJ) for solar pointing. Failure of a SARJ would greatly degrade the capability to orient half of the power channels for solar pointing, but would only

affect the core channels of one power domain. However, redundancy was built into the SARJs themselves, and they can be controlled by either domain (see below).

Overall, redundancy of ISS systems is provided by identical redundant equipment (i.e., a prime and a backup) that are separately powered by one of the two power domains. However, some device power supplies were designed to have multiple inputs, meaning the same piece of hardware can be powered by the two different domains so that if one should fail, operation would not be interrupted. Dual power feeds are more common to payload equipment where power redundancy supports mission success for that unique payload hardware, versus separate fully redundant critical systems equipment required for ISS safety.

#### ***Off-nominal—Power Channel Cross-ties***

Failure of a power channel can have wide-ranging impacts to both the ISS systems and the payloads. The USOS power system was designed to be able to electrically connect the primary power outputs of the channels, called “cross-tying,” to provide some flexibility in the face of a power channel loss. The channels can be tied together in a specific order using the Main Bus Switching Units (MBSUs), which will be discussed in more detail.

Originally, the capability required that a power channel output be removed before another channel could be tied to additional downstream loads to prevent the two power channels from trying to power the same bus, which could potentially cause instability and additional failures. This would

require the deactivation of all loads associated with the channel being shut down. Known as a “cold cross-tie,” this capability works well when a channel shutdown/loss is unavoidable or unexpected. However, if a power channel was planned to be shut down, it would be beneficial to allow downstream loads to remain powered and seamlessly move them to a good power channel.

The operations and engineering teams developed a process of using software and hardware already on board to perform a seamless power channel handover or “hot cross-tie.” Depending on overall power demands, some loads on either channel may still need to be powered down to prevent overloading the good channel. The voltage set points of the suspect channel would be lowered within the Primary Power System control range by using software and firmware commands. The MBSU cross-tie function would then be used to electrically connect the suspect channel to a good channel—one operating at the nominal Primary Power System voltage—without the loss of all downstream loads. In other words, the solar array output of the suspect channel would be taken off-line and its batteries would be configured to discharge at a lower voltage than the batteries of the good channel. Therefore, when the suspect channel sees the nominal voltage level, its batteries will start charging, and the good channel will supply power to the downstream loads. The Primary Power System portion of the suspect channel can then be gracefully deactivated or configured to a dormant/keep-alive configuration until required maintenance is completed.

### ***Contingency—Jumpers***

Whereas cross-tie functionality provides for the loss of a power channel, certain failures in the Secondary Power System or Thermal Control System would still remove power from critical ISS systems. As the ISS was assembled, the operations and engineering teams devised the use of physical connectors and cables to “jumper” around these failures, kind of like an electrical detour. Sometimes these jumpers make use of electrical connections that were originally intended for temporary use during ISS assembly (see Introduction). For example, the Lab-Truss Contingency Jumper provides secondary power from a DDCU inside the US Laboratory module to critical loads on the P1 or S1 truss segments. This capability originally existed to provide power to truss loads prior to the permanent ETCS activation, and can now be used if an ETCS loop fails. Other jumpers reroute power between DDCUs, potentially stealing power from payloads for critical systems (e.g., sacrificing science to maintain life support).

Specific jumper cables and procedures have been designed for multiple failure scenarios. However, not all scenarios can be covered. The potential for a failure to cause the loss of a particular device that is needed for safety or mission success still exists. In these cases, the crew could use spare electrical wiring and a pin kit to build a new connection (see Chapter 16). A solution cannot be guaranteed, but the operations support officers and the engineering teams have often proven their ingenuity and creativity in the use of pin kits in the face of unexpected failures. The downside to any jumper is that

the crew must take physical action to install it. This can pull the crew away from scientific research, create the need to wake the crew in the middle of the night, or, worst case, cause an extended duration of equipment loss if the crew is unavailable to install a jumper. When an external cooling pump failed in 2010 and again in 2013 (see Chapter 20), jumpers were used to provide power to redundant systems until a spacewalk could be performed.

### ***Contingency—Planning, Energy Balance, and Load Sheds***

The solar array of each power channel can produce approximately 30 kilowatts (kW) of power—or about three times the average household power consumption in the United States. However, once Primary Power System battery charging, housekeeping power (i.e., the power needed to operate the EPS devices themselves), and inefficiencies (i.e., energy lost, often in the form of heat, due to resistance in cables and during voltage conversions) are accounted for, each power channel can nominally supply about 12 kW of power to downstream loads. Higher loads, up to approximately 15 kW, can be supported for short durations at the risk of having an additional single-point failure cause an entire channel to trip off. Many factors can lower the power generated by a channel. The inability of solar arrays to track the sun, the ISS in an off-nominal attitude, or Primary Power System failures or maintenance can all lower the power available from a power channel.

Power planning is one of the most work-intensive, ongoing operations for the Station Power, Articulation,

Thermal, and Analysis (SPARTAN) flight controllers. Power planning includes determining the power availability and the load demand of each channel. Power availability is mainly driven by the solar array configurations and external environmental forces. During normal operations, the ISS solar array rotary joints are configured to track the sun as the vehicle moves along its orbit, thus maximizing the solar energy gathered for power production. However, due to multiple constraints, dynamic operations such as visiting vehicle arrival or departure and spacewalks may require the solar arrays to be fixed in specific positions called solar array “feathering.” Typically, at least one solar array feathering event happens weekly. When the solar arrays are not actively tracking the sun, power production can be greatly reduced to the point of not providing enough power to meet minimum power channel loads. Also, the natural occurrence of changing solar beta angle (see Chapter 7) affects the total power generation on the ISS. Low beta angles cause longer eclipse periods (i.e., where the arrays do not receive sunlight), which drove the design of the Primary Power System batteries. Eclipse periods are shorter at high beta angles; at their maximum value, the ISS is in continuous daylight for multiple days in a row. Although more sunlight might result in more power, it also impacts operations (e.g., the equipment can get too warm). If the Primary Power System batteries are not discharged, they can overcharge, thereby causing damage to the batteries. Or, they can develop a memory, meaning the full depth of discharge (i.e., time

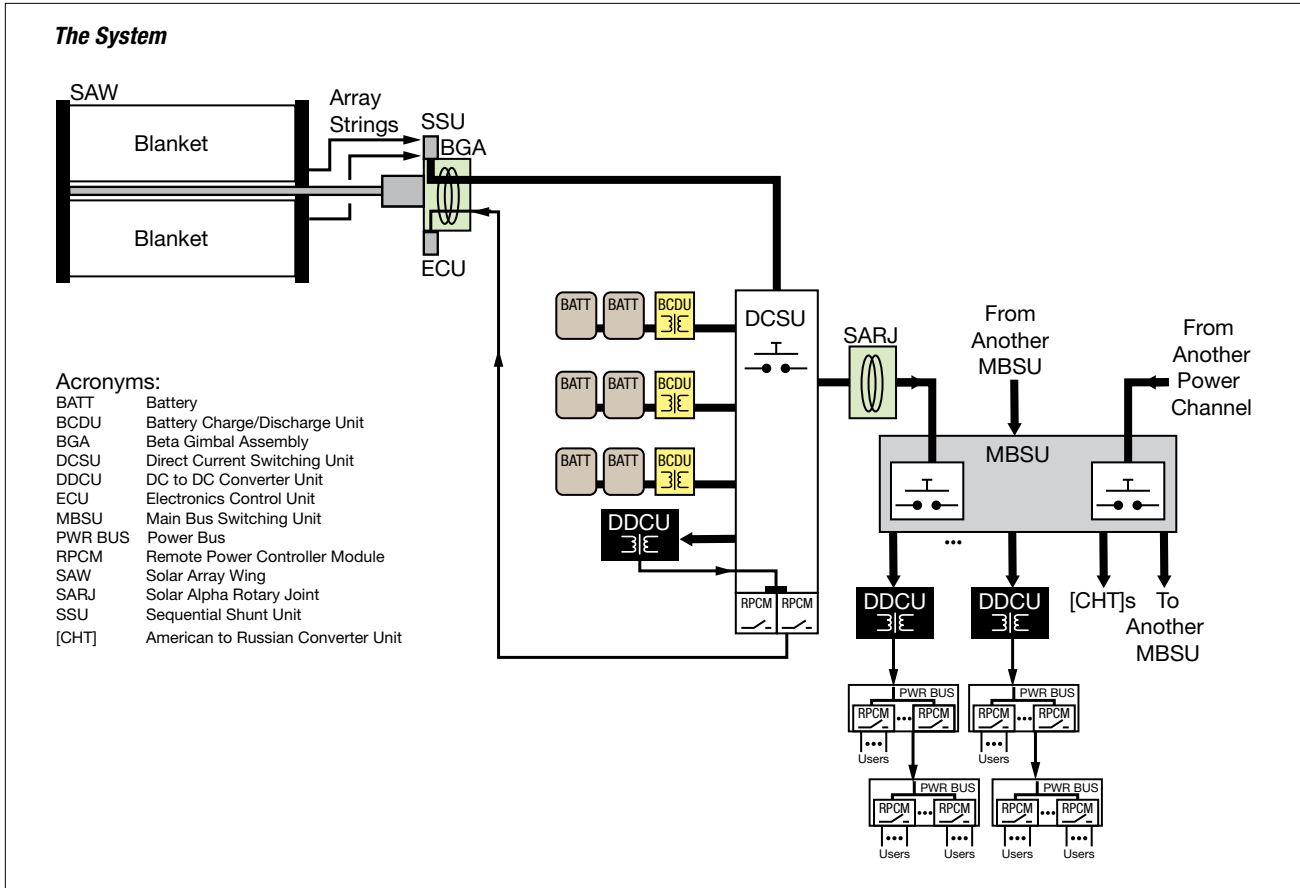
that a rechargeable battery can last on a single discharge) would not be available. Ground controllers must actively manage battery states of charge during high beta operations by reducing the current used to charge batteries and occasionally deactivating batteries to prevent them from overcharging. As a result, some of the power that is generated is wasted and cannot be used by the EPS. Annually, batteries must be reconditioned by taking each battery off-line and completely discharging it to remove any memory buildup and allowing the state of charge (SOC) software calculations to be updated. Additionally, the high inclination of the sun with respect to the orbit of the ISS can cause parts of the ISS structure to cast shadows across the arrays. This can reduce power-generation capability, cause changes in nominal heater control cycles (i.e., some items getting warmer or colder than normal), and potentially cause thermal stresses on hardware (see Longeron Shadowing, discussed below). ISS Program management has Groundrules and Constraints (see Chapter 1) that limit scheduling of dynamic events at high beta, due to these environmental effects of high beta and the solar array constraints often associated with dynamic operations. For example, visiting vehicles are generally not allowed to dock at these times of the year.

The SPARTAN team develops a weekly solar array plan that takes into consideration any solar array positioning requirements and determines a time-phased power availability for each power channel. This availability is then adjusted

for any Primary Power System maintenance that is planned, such as battery reconditioning. At the same time, the SPARTAN team gathers inputs from control centers around the globe to develop a usage profile that includes the standard systems power requirement (i.e., the overhead to keep the ISS operating), dynamic events loading, and payload requirements. The power availability is then compared to the load profile to determine whether the power system will be balanced. The strictest definition of energy balance would have the Primary Power System batteries discharge and recharge match on each orbit.

From a planning perspective, the operations team plans for the batteries to fully recharge each orbit and is limited to a maximum discharge down to 65% SOC to prevent excessive wear on the battery hardware and maintain contingency reserve power in case of a failure preventing a battery from recharging. Furthermore, this protects the vehicle from significant failures. For example, if a system failure that will take a few hours to fix occurs when the batteries only have 30% to 40% SOC, there is a higher chance the system will lose all power before a recovery. If the power availability is greater than or equal to the load profile, the system is considered to be in positive energy balance (i.e. generating more electricity than is being used). If the power availability is less than the load profile, the system is in negative energy balance. Positive energy balance will allow the batteries to recharge to the same point they started on the previous orbit—hopefully fully

charged. Negative energy balance will prevent the batteries from fully charging each orbit and will cause the batteries to discharge further each orbit until they deplete their usable energy. Negative energy balance on the ISS is often caused by dynamic events that create the need for solar array feathering, thus reducing the power availability. If, during weekly planning, the initial comparison of power availability to the load profile shows the ISS will be in negative energy balance, the operations team will work through multiple options to correct the situation. Usually, the team will develop a manual powerdown plan. Through this plan, ground controllers will deactivate noncritical equipment for the duration of the energy-negative timeframe, usually on the order of 2 to 8 hours. If a suitable powerdown cannot be found, it may be necessary to postpone an activity (e.g., dynamic event, payload, etc.) until power is available to support it. It may possible for the ISS to continue in negative energy balance during rare, high-priority, short-duration events. This would potentially cause additional wear of battery hardware and eat into the power available for contingencies. These cases are weighed against the risks of replanning the high-priority event (e.g., delaying the docking or spacewalk). All these operations are carefully defined in the flight rules, which detail under what conditions the batteries can be discharged below the nominal limits. The flight director will weigh these considerations when determining what level will be tolerated.



**Figure 2.** Diagram of an ISS power channel. Power is generated in the SAW and then passed through the SSU in the BGA to the DCSU or back to the arrays if too much electricity is being generated. The DCSU sends the power either to the batteries for storage or to downstream loads. From the DCSU, the power passes through the SARJ to the MBSUs. Electricity from the MBSUs can then be fed to other MBSUs, DDCUs, or Remote Power Controllers.

## Primary Power System

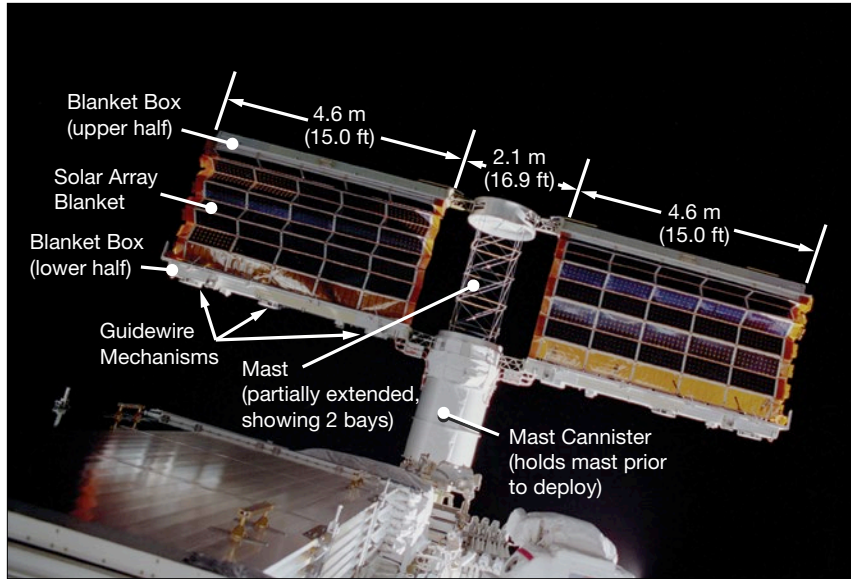
As mentioned above, the Primary Power System (Figure 2) is the portion of the EPS that operates at a high voltage and includes the hardware needed to generate power during insolation, store and provide power for eclipse, and distribute power to the Secondary Power System. Most Primary Power System hardware is located on the PVMs associated with each power channel. The Primary Power System operating voltage range is  $155 \pm 22$  Volts DC

to provide flexibility and account for hardware degradation as the system ages. Usually, the solar arrays provide 160 Volts DC during insolation, whereas the batteries provide 151 Volts DC during eclipse.

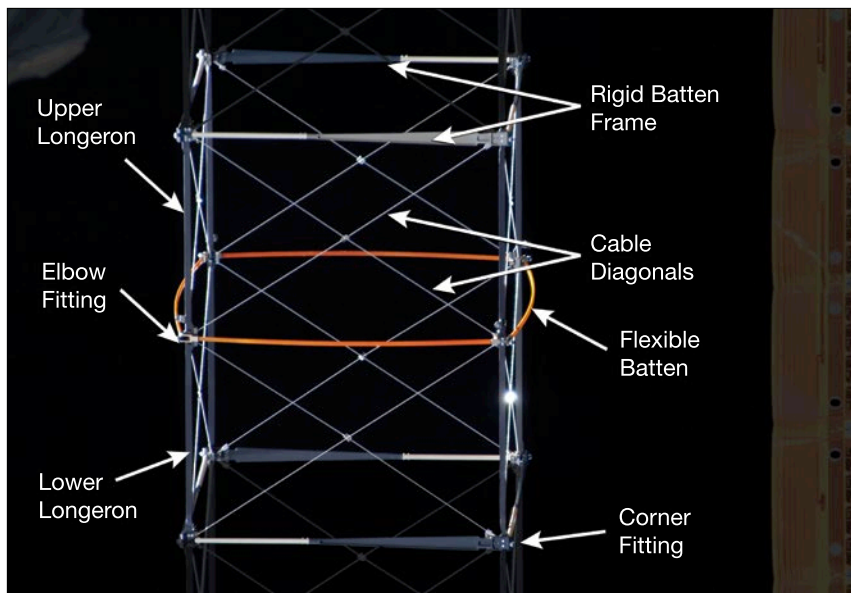
### Solar Arrays

Each USOS power channel has one Solar Array Wing (SAW) that contains the equipment necessary to deploy or retract the array, structurally support the array on orbit, and collect solar energy. Each

SAW has two solar array blankets that contain 16,400 solar cells (32,800 cells per SAW). The cells are grouped together into strings that are combined to produce the voltage and current necessary for power channel operations. Each blanket also contains diodes between each string so that each string can be bypassed in the event the string is damaged or unable to produce power. A collapsible mast made up of longerons, battens, and cables is positioned between each blanket (Figures 3 and 4).



**Figure 3.** Partially deployed solar array showing two bays extended (see also Figure 4).

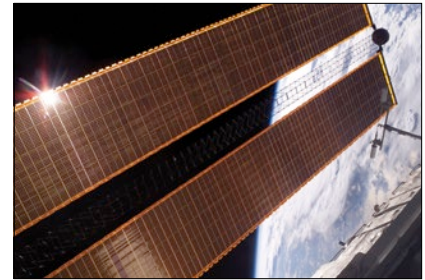


**Figure 4.** Solar array mast components. The longerons are collapsed when in the mast canister and then lock into place after extension.

When retracted, each blanket folds into a box that is 51 cm (20 in.) tall. The mast is collapsed into a canister that is 2 m (6.6 ft) tall. When deployed, each SAW is 35 m (115 ft) long. A series of cables and a motor are used to deploy, retract, and hold a

SAW taut. Each SAW was deployed during the ISS assembly Space Shuttle mission that delivered the associated PVM (Figure 5).

The P6 SAWs, channels 2B and 4B, were retracted during the ISS



**Figure 5.** Deployment of ISS solar arrays, showing the beginning of deployment with a couple of bays deployed (top), partially deployed with 16 bays (middle) and fully extended with all 32 bays extended (bottom).

assembly sequence when it was necessary to move the P6 truss segment from its temporary location on top of the Z1 truss. The P6 SAWs were then redeployed during the STS-120/ISS-10A mission. The team experienced a lot of difficulties in getting the solar array blankets to retract and fold neatly into their boxes. Although this proved ultimately successful with the assistance of extravehicular activity (EVA) crew members, one of the channel 4B solar array blankets was damaged during the redeploy and required contingency EVA repair using unplanned/built-

on-the-fly materials (see Chapter 18). Due to these difficulties, no further plans have been made to retract the USOS solar arrays. However, some EPS maintenance requirements (i.e., Sequential Shunt Unit [SSU] replacement) originally called for solar array retraction to safe electrical connections. With no way to “turn off” the sun, and with the retraction option essentially off the table, the operations community had to develop plans to perform these maintenance tasks with time-critical steps during limited eclipse periods. This is another example of the designer’s intentions being changed through the lessons learned by operating the ISS.

### ***Sequential Shunt Units***

The SSU is the primary power regulation device that controls SAW output. The SSU maintains its Primary Power System voltage set point (typically 160 Volts DC) by balancing the system demand with the number of connected array strings. Each array string can be individually connected or disconnected from the primary power bus. Array strings that are disconnected from the power system are shunted (shorted or rerouted back to the array). The output from the SSU is therefore the sum of all connected strings at any given time. The SSU also contains multiple safing functions that cause it to automatically shunt all array current, including output overvoltage (indicating that the SSU is not functioning correctly) and output undervoltage (indicating a possible electrical short downstream).

### ***Batteries***

The actual storage devices of the Primary Power System batteries are nickel hydrogen battery assemblies—three per power channel. In early

2017, the team began replacing the nickel-hydrogen batteries with lithium-ion batteries. The new batteries provide more energy storage in a smaller box, with one lithium-ion battery replacing two nickel-hydrogen batteries. The batteries store power throughout the entire orbit. Array power is used to charge the batteries during insolation. A portion of the stored battery energy is discharged to supply the ISS loads during eclipse. Energy from the batteries may also be used to supplement the power-generation function during insolation. For example, if the load on a power channel is temporarily higher than the solar array can supply due to overloading, shadows cast by other space station structure, solar arrays purposely not tracking the sun, or a failure, then the batteries will discharge in parallel with the solar array output to maintain sufficient power to downstream loads. If all batteries are fully operational on a channel (i.e., not undergoing maintenance), the USOS EPS is designed to only discharge down to 65% SOC to supply the nominal ISS power needs during the period of orbital eclipse and can then be fully charged during a single period of insolation. The additional battery capacity would be used to support loads if solar array input power were to be lost.

### ***Battery Charge/Discharge Units***

The Battery Charge/Discharge Units (BCDUs) control the charging and discharging of the power channel batteries. During insolation periods, the BCDUs will charge, and then maintain the batteries at their maximum SOC. The discharge unit converter is a bidirectional power converter that can regulate the current

level for charging the battery and regulate the voltage level produced when discharging the batteries. Typically, the BCDUs are set to regulate the output voltage level to 151 Volts DC. When the SSU is producing power (set point of 160 Volts DC), the BCDU will sense the output voltage above its set point and operate in a battery-charging or maintenance mode. When the SSU output voltage drops, the discharge unit will begin to reduce the battery-charging current; when the voltage drops below the BCDU set point, the BCDU will begin discharging the batteries to maintain power to downstream loads. This transition is automatic and happens without crew or ground interaction. BCDUs also provide backup power to the Primary Power System components of the other power channel on the same PVM. This power enables only command and control of these components, and cannot be used to supply power to the downstream loads of that channel.

## **Secondary Power System**

### ***Direct-Current-to-Direct-Current Converter Units***

The DDCUs are the interface between the Primary Power System and the Secondary Power System. They convert the primary power range of  $155 \pm 22$  Volts DC to the tightly regulated secondary voltage level of  $124 \pm 1.5$  Volts DC. Numerous converter units are distributed throughout the USOS. In general, units are located in close proximity to the loads they power due to their operating at a lower voltage and higher current, which in turn requires larger cabling after

conversion. The three types of DDCUs include: external, located on the truss segments; internal, located inside pressurized modules; and heat pipe units, located on the Z1 truss. Although multiple differences exist, the main distinguishing feature of these converter units are how they are cooled. External DDCUs (cooled by the ETCS loops) and internal DDCUs (cooled by the Internal Thermal Control System) (see Chapter 11) are each designed to output 6.25 kW of power. Heat pipe DDCUs are rated to output only 3 kW of power due to the limited cooling provided by the heat pipes (i.e., small radiators that rely on the release of heat during the phase change of liquid ammonia to gas instead of active pumps).

External and heat pipe DDCUs share the same external housing (i.e., thermal insulation and micrometeoroid shielding), which is not required for the internal units. The DDCUs operate on a demand-feed basis, meaning they will try to feed any amount of downstream loads, up to their maximum output trip limits. As the current draw increases (i.e., more loads), the voltage on the output decreases. The converter unit senses this drop and increases its power output to maintain the set point. Similarly, as loads are turned off, the current decreases, thereby increasing the voltage. The DDCU will sense this increase and respond to by decreasing its output. Two DDCUs are configured in a parallel configuration in several locations. In this configuration, each one receives primary power from a different power channel; however, the outputs of the two units are merged together to allow up to 12.5 kW to feed downstream loads. As long as

the load is not greater than 6.25 kW on a single DDCU, these DDCUs can be configured to balance loads between the two input channels. If one of the parallel convert units were to fail, the other could still support up to 6.25 kW of downstream loads. The DDCUs have multiple safing functions that will automatically deactivate the unit if off-nominal input/output currents, voltages, or temperatures are detected by on-board computers.

### ***Power Distribution***

Once power has been generated and stored, it needs to be routed to the DDCUs to be converted to secondary power levels. Then it should be further routed to downstream loads, where the crew and ground controllers can activate and deactivate individual loads. The power distribution devices handle all of this. Additionally, the power distribution devices provide a large part of the trip coordination safing function that was discussed earlier. This function is performed primarily by Remote Bus Isolators (RBIs) and Remote Power Controllers (RPCs).

### ***Remote Bus Isolators***

RBIs are bidirectional, electromechanical relays that provide electrical paths between electrical buses—i.e., bundles of wires. This bidirectional capability means power can flow either way, allowing different power sources such as the solar arrays, batteries, or other power channels to reach downstream loads. RBIs can be remotely opened or closed via command and have overcurrent safing trips for current flowing in either direction. The specific limits on the current are part

of trip coordination and will vary depending on the location of the RBIs in the EPS architecture.

### ***Remote Power Controllers***

RPCs are solid-state power switches. They allow power to be transmitted one way to the downstream loads. RPCs of various output current ratings can be found across the ISS and are used to provide power directly to user loads. These are the most common switches used by the crew and ground controllers to activate or deactivate loads. RPCs are, in effect, circuit breakers—similar to those in most households—that can be remotely commanded open and closed.

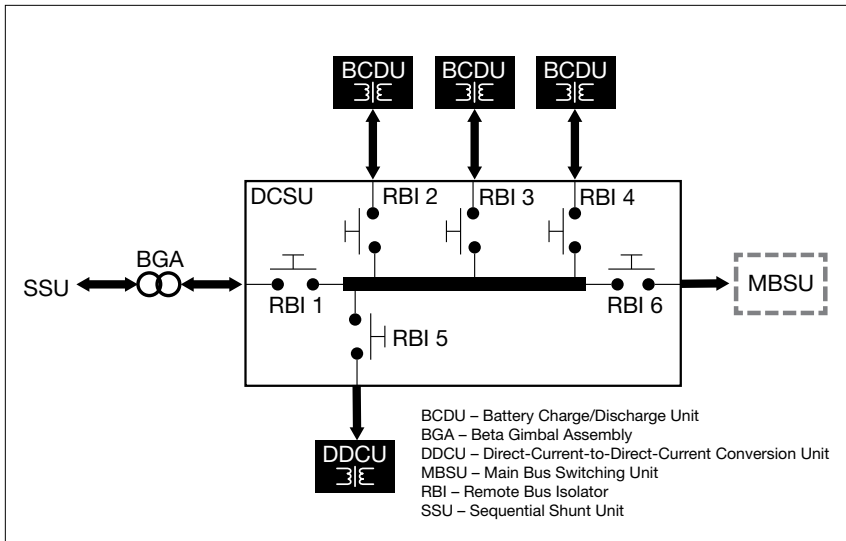
### ***Direct Current Switch Units***

The Direct Current Switch Unit (DCSU) is the electrical distribution box for a primary power channel. It routes power between the solar arrays' SSU input, BCDUs' batteries, and to downstream MBSUs or DDCUs. It also provides fault protection between each of these devices. See Figure 6.

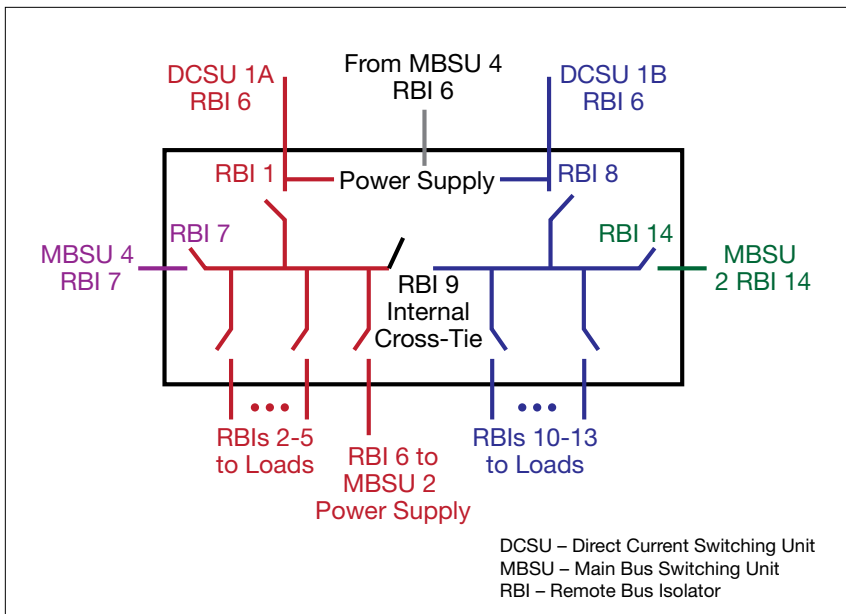
DCSUs are primarily an electrical bus with six RBI connections, seen in Figure 6. RBI 1 is the input power from the solar arrays or the SSU. RBIs 2, 3, and 4 are the feeds for charging or discharging the batteries, whereas RBIs 5 and 6 provide power to downstream loads.

The DCSU power supply has three possible inputs. A BCDU located on the opposite power channel of the same truss segment provides backup power. It can also receive power from the solar array and batteries of the channel, or by backfeeding power from another channel.





**Figure 6.** DCSU distribution. Electricity comes in from the SSU through the BGA and, depending on the configuration of the RBI, is passed to BCDUs and downstream loads.



**Figure 7.** Example MBSU #1 distribution showing how power can flow using the RBIs to feed different DCSUs.

### Main Bus Switching Units

The MBSUs are used to distribute primary power from the power channels to downstream DDCUs and other loads. They also provide

the capability to cross-tie primary power channels to feed those DDCU loads in the event of a power channel failure or to restart a power channel. The S0 truss segment contains four MBSUs,

each of which has input from two primary power channels and outputs to several DDCUs or USOS to RS power converters. See Figure 7.

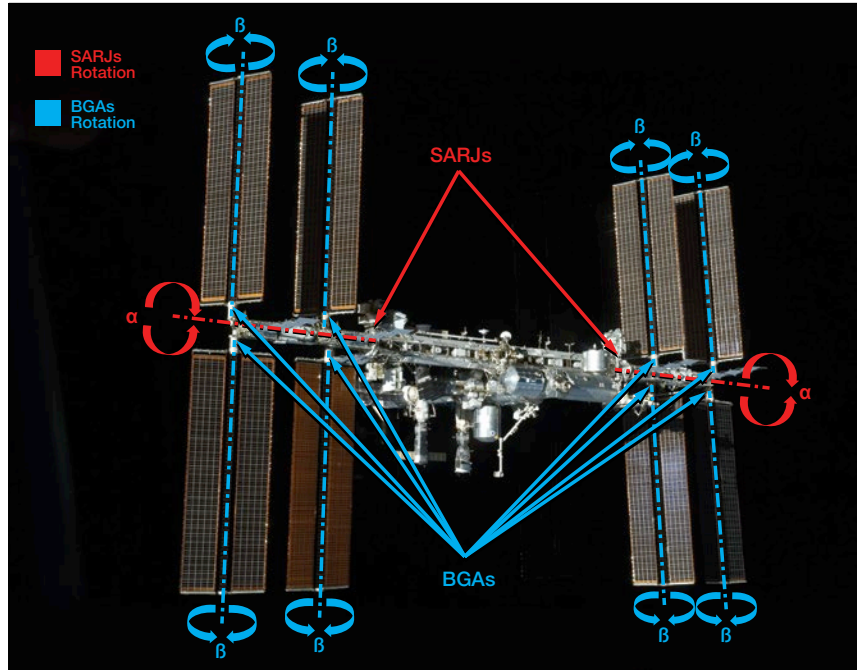
The MBSUs provide a great deal of flexibility and redundancy in the electrical system by allowing various power sources to be connected, or tied, to other channels. Each MBSU contains two electrical buses and 14 RBIs. RBIs 1 and 8 are nominally the input power from primary power channels; however, they can be used to backfeed power to a primary power channel, if needed, following a power channel failure. Other RBIs (2 through 5 and 10 through 13) are outputs to downstream loads. The ability to cross-tie the inputs to different buses is accomplished by closing RBIs that connect those power channel buses. The two buses internal to the MBSU can be cross-tied by closing RBI 9. Since RBIs 7 and 14 are connected to adjacent MBSUs, they can be cross-tied to other power channels. Although it would be technically possible to tie all downstream loads to one power channel, the channel would not have the power availability to actually power all of those loads. Similar to the DCSU power supply, the MBSU power supply has three possible inputs, which provides for a great deal of operational flexibility. Power can be provided upstream of RBIs 1 and 8, allowing either input power channel to supply an MBSU. Another MBSU can provide backup control power via RBI 6 to allow cross-tying as necessary if power was lost from both power channel inputs.

## Power Buses

Power buses provide the physical mounting structure for Remote Power Control Modules (RPCMs) and provide access to command and data interfaces, power input and output connections, and cooling. They do not have any active components (i.e., no moving switches or gears) and only provide structural, thermal, power, and data support for RPCMs. The number of RPCMs in each power bus varies depending on power requirements in that particular location of the vehicle. Power buses were not designed to be replaceable and can be found both internally and externally on the ISS.

## Remote Power Control Modules

The RPCMs are the interface between the EPS and all non-EPS equipment on board the ISS. Because RPCMs are the most numerous EPS devices on the ISS, and due to their direct interface to downstream loads, the crew and ground have the most interaction with these items. The distribution of secondary power to downstream loads can be controlled by opening and closing RPCs within the RPCMs. Protection of the EPS against downstream faults is accomplished by opening RPCs when too much current draw is detected. The RPCMs come in six different configurations, each with a different number of RPCs with different current ratings and current-limiting capabilities. The type of RPCM used in any particular location depends upon the downstream load requirements. All RPCMs have the same housing and the same standard interface connectors, and can be located either externally or internally to the ISS.



**Figure 8.** US Segment solar array angle rotation showing the rotation of the SARJ and the Beta Gimbal Assembly (BGA), as indicated. The BGAs allow the arrays to compensate for the  $\beta$  angle (see Chapter 7, Figure 7), which changes slowly over the year. The SARJ nominally rotates  $360^\circ$  as the space station rotates around the Earth to always keep the solar cells facing the sun. This angle is called the “ $\alpha$ ” (alpha) angle.

## Pointing Systems

To maximize the power generated by the USOS EPS was designed with multiple articulating joints to allow the solar arrays to be rotated to point at and track the sun as the ISS orbits the Earth. Two separate kinds of rotary joints are used to position USOS solar arrays (Figure 8), due to the changing alpha and beta angles and the potential need to change ISS attitudes (see Chapter 7).

### Solar Alpha Rotary Joints

The SARJs rotate the PVMs—entire truss segments—to provide alpha angle array pointing capability (i.e., when the ISS is in the nominal +XVV attitude). The port and starboard SARJs are located at the

outboard end of the P3 and S3 truss segments, respectively, and provide  $360^\circ$  continuous rotational capability to the segments outboard of P3 and S3. The rotary joints normally complete one  $360^\circ$  revolution during each 90-minute orbit of the ISS around the Earth. Essentially, the SARJs are large gears rings with supporting bearings and drive motors. Each SARJ features two redundant control strings, one powered from each power domain. Each string consists of firmware controllers that include sensors to monitor the position and rotational speed of the SARJ, along with drive/lock assemblies that house the motor, gear teeth, and locking racks used for positioning. See Figure 9.

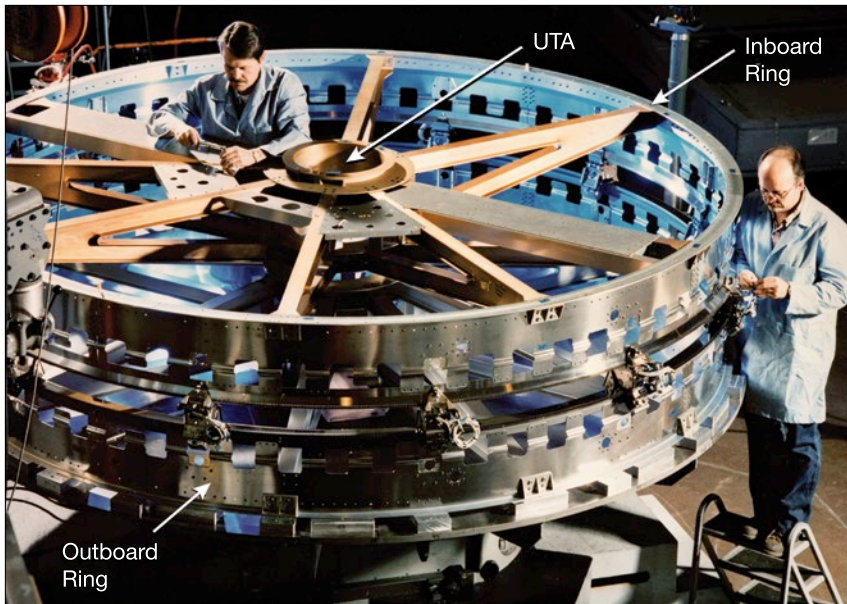


Photo credit: McDonnell Douglas Image s07-17081

**Figure 9.** Photo of a SARJ. The SARJ consists of two rings, with a utility transfer assembly (UTA) on the axle and two drive/lock assemblies (not shown). The rings consist of teeth (see Chapter 18) that move like a bike chain on the gear sprocket. The drive/lock assembly is used to either turn the gear teeth or lock the ring in position. The UTA allows commands and telemetry as well as electricity to pass back and forth using a roller ball assembly, shown in Figure 10.

A utility transfer assembly (UTA) is located at the center of each SARJ and provides the path for power and data transfer. The UTA has a roll ring structure, which consists of multiple stationary metal plates surrounded by rotating metal rings. Flexible metal rollers, called “flexures,” between each plate and ring maintain a continuous conducting path to pass electrical power or computer signals between the stationary plate and rotating ring. One plate-roller-ring set is required for each power or data connection that must pass through the rotating joint. These roll rings allow for 360° continuous rotation with seamless power and data conduction. See Figure 10.

### Beta Gimbal Assemblies

The BGAs rotate individual SAWs to provide beta angle array pointing capability (i.e., when the ISS is in the nominal +XVV attitude). Normally, each BGA will rotate approximately  $\pm 4^\circ$  a day to compensate for the changing solar beta angle as the Earth orbits the sun. The BGAs provide the structural load path connecting the SAWs to the ISS truss structure while providing 360° rotational capabilities. They include roll rings for data and power transmission (similar to the SARJ UTA), a motor for SAW positioning, and two redundant anti-rotation latches for locking the BGA in specific positions. Software operates the BGA using multiple “modes.” The autotrack mode—the nominal mode—uses data from the Guidance, Navigation, and Control MDM on the relative positions of the ISS and the sun to calculate the angle that the BGAs should be moved to track the sun. The rate mode uses

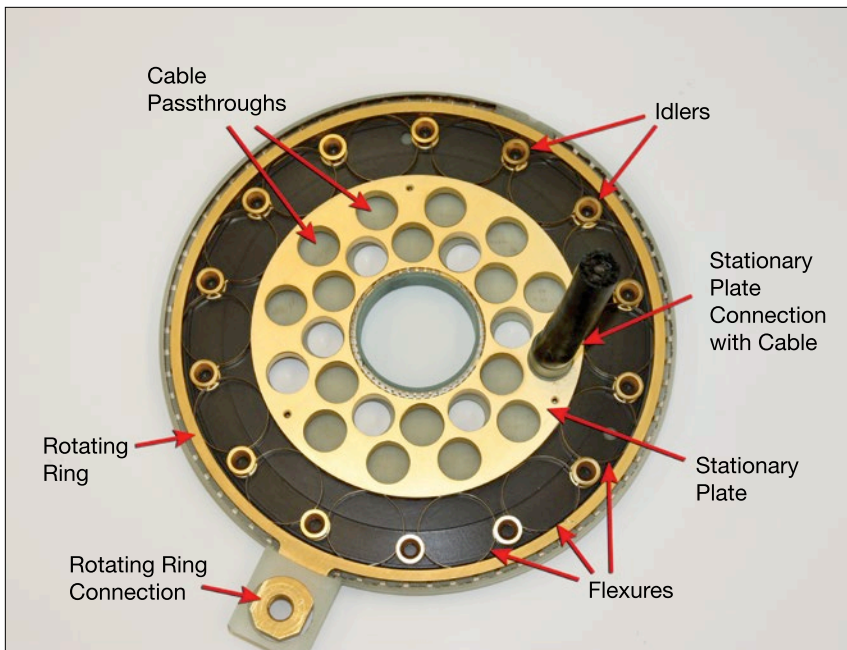


Photo: Courtesy of Robert C. Dempsey

**Figure 10.** Example roll ring. The gold stationary plate stays fixed while the outer section rotates. Part of a cable (black) is shown in one of the passthroughs on the inner stationary ring (the rotating ring connector is empty in this photo). Power or data is conducted through the metal flexures between the stationary and rotating rings to transfer electricity or data.

a commandable (i.e., set by the SPARTAN flight controller) velocity to rotate the array at a constant rate irrespective of the relative motion of the sun. Rate mode does not automatically track the sun, therefore reducing power generation. It is only used in special circumstances, such as verifying the rotational capability of the BGA or obtaining imagery of all sides of the SAW. The directed position mode uses a commandable position to fix the BGA at a specific angle. Once in position, a motor will hold the BGA at the command position by attempting to correct for any external forces (i.e., thruster plume impingement). In cases where visiting vehicles are docking, it is desirable to park the BGAs at a fixed position to minimize plume impingement but at the expense of generating power. However, in safety-critical situations (i.e., an EVA crew member working near the arrays), one of the anti-rotation latches can be used to mechanically inhibit BGA rotation. In manual free mode, the motor is disabled, thereby allowing free rotation of the gimbal assembly. This mode might be used following a BGA failure by allowing an EVA crew member to manually position the SAW for better power generation for repair.

### **Solar Array Constraints**

The USOS solar arrays can be rotated into any position required to point at the sun—barring any shadowing from other hardware—through the combined use of the SARJs and BGAs. After the ISS was completely designed, many constraints were applied to solar array positioning to protect the solar array hardware from damage.

### **Thruster Plume Impingement—Structural Loads and Array Erosion**

Thrusters that control attitude on the ISS and visiting vehicles work by combusting fuel and oxidizer. The combustion products exit the thruster nozzle at a high speed, thus imparting a force on the vehicle in the opposite direction. The departing combustion products are known as a thruster plume. Thruster plume impacts, or impingement, on the USOS solar arrays, can have two effects—both negative. First, the thruster plume can impart a force on the solar array structure and cause bending and/or torsional loads. If these loads are too high, the solar array structure can be damaged. Second, if combustion products come in contact with solar cells, they can chemically or abrasively degrade the cells. This degradation would reduce the capability of the solar arrays to produce power. To combat the negative effects when the thrusters are firing, the USOS solar arrays are stopped and positioned facing edge on to, and as far as possible from, the thrusters. This reduces the forces imparted on the solar arrays and their exposure to combustion products. Many thruster plumes need to be avoided, especially when visiting vehicles arrive to or depart from the ISS, which creates a narrow range of acceptable locations for the USOS solar arrays. The less flexibility on solar array positions, the more power constrained the ISS, requiring load powerdowns to stay in energy balance. If the forces involved are high enough, the BGAs or SARJs (or both) may be mechanically locked into position to prevent inadvertent, perhaps plume-induced, rotation into a position that would risk damage to the solar array.

### **Longeron Shadowing**

When the USOS solar arrays were deployed, some of the components combined to form four longerons that run the length the mast of each SAW. See Figure 4.

When a solar array is tracking the sun, each of the four longerons are exposed to sunlight. However, if the solar array is not tracking the sun (e.g., parked for thruster constraints) or if other equipment blocks the sun (i.e., during high beta), it is possible these longerons can become shadowed. Whether a longeron is in sunlight or shadow will change the temperature of the longeron and can cause it to expand (lengthen) or contract (shorten). If the longerons of a single array mast are unevenly shadowed (e.g., three longerons fully in the sun while one longeron is fully in shadow), this expansion and contraction can cause uneven tension and compression loads on the longerons. Analysis has shown that uneven shadowing for as few as 20 minutes can cause enough thermal loading differences to damage the mast.

When the constraints to prevent longeron shadowing and thruster plume impingement are combined, it can be very difficult to develop a solar array plan that protects solar array hardware while still producing enough power to meet the ISS needs.

These constraints came about mainly due to design changes from early space station concepts. The biggest design change that magnified these solar array constraints was the addition of Russia as an international partner. The USOS solar arrays were originally designed for the Space Station Freedom. When Russia joined

the partnership, two major changes occurred in design modification from Space Station Freedom to the ISS that impacted the USOS solar arrays. First, the RS was added to the ISS design and included thrusters for vehicle attitude control. This eliminated the need for US Orbital Segment thrusters, which had been designed to limit plume impingement on the USOS solar arrays. The RS modules (and their associated attitude control thrusters) were based on elements of the Mir space station and did not take into consideration USOS solar array design or structural capabilities. Second, when Russia joined the ISS partnership, the inclination of the space station orbit was changed from 28° to 51.6° to make full use of Russian launch vehicle capabilities. This change in inclination also altered the beta angle range that the space station would see. At 51.6° inclination, the ISS would experience beta angles up to  $\pm 75^\circ$ , which would cause times of no eclipses for days. In addition to exposing hardware to high temperatures at high beta angles, components of the ISS can cast shadows on other station equipment and thereby reduce solar power generation or create thermal gradients (i.e., longeron shadowing) that were not figured into the original design.

Another constraint that has been applied to the USOS solar arrays is their use in reducing (or increasing) atmospheric drag on the ISS. Even at the orbital altitude of the ISS, there is enough of an atmosphere for the large surface area of the USOS solar arrays to cause drag on the ISS, especially when facing the direction of motion. This drag, although small, adds up over time, thus lowering the ISS attitude and causing the need for reboosts (see Chapter 7). To

combat this constraint, the software used to calculate solar array angles to track the sun allows for biases to be applied. Biasing the solar array position can turn it more edge on to the velocity vector to reduce drag. Of course, this also turns it away from the sun, thereby reducing power generation and potentially causing longeron shadowing. This constrains when and how much bias can be used. As the ISS software developed over time, this biasing strategy was automated, which subsequently reduced the workload for ground controllers. Although uncommon, this strategy has occasionally been reversed to increase drag on the ISS to meeting visiting vehicle phasing constraints, as discussed in Chapter 14 (i.e., being in the right place at the right time for rendezvous or departure) without needing to burn propellant to deboost the ISS.

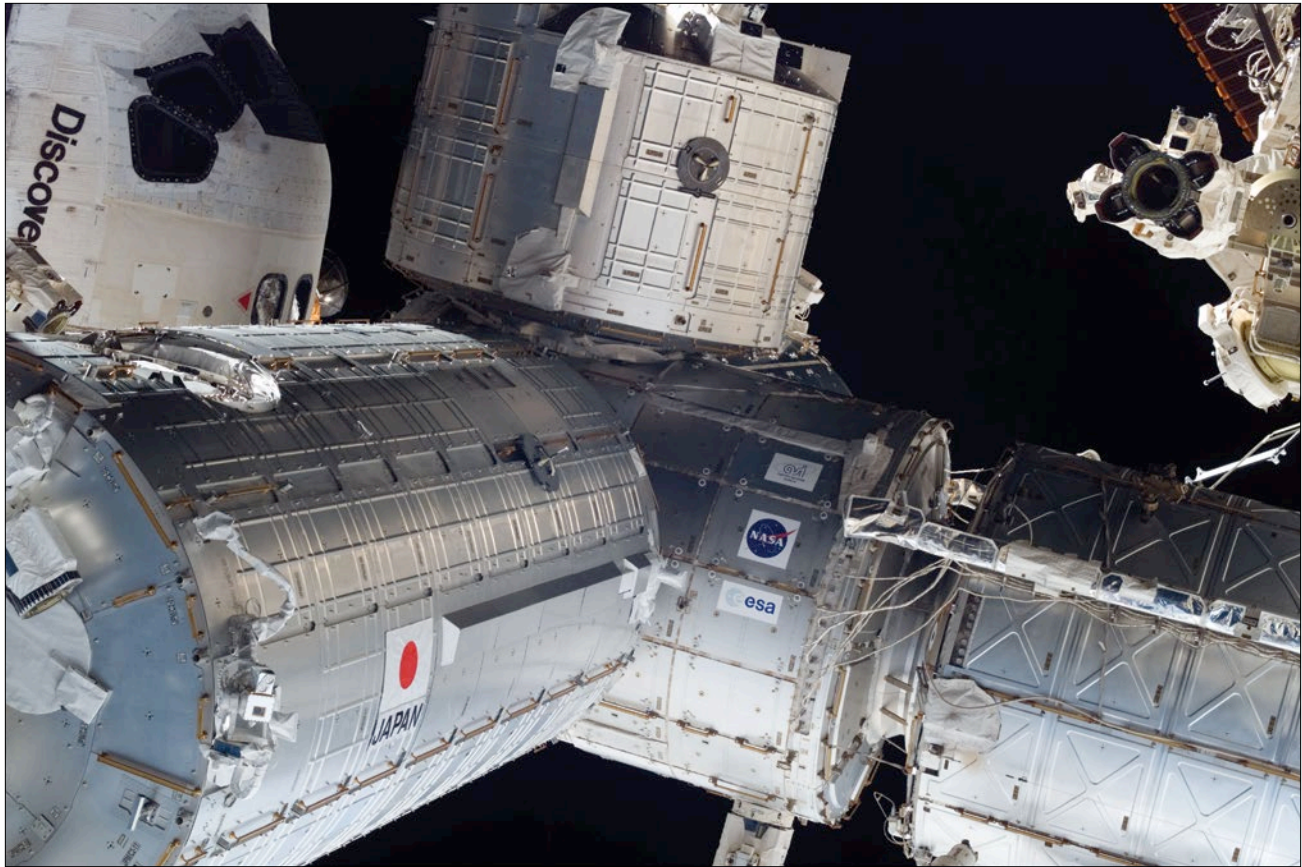
## Conclusion

Operating the largest orbital solar power platform has been challenging, yet highly successful. Many design decisions and design changes have driven the need for automated software control and sophisticated analysis tools. The SPARTAN team continuously plans and adjusts EPS configurations to protect the ISS hardware and maintain power availability to critical systems and scientific payloads. The team must also be ready to respond to system failures or maintenance by adjusting plans or rerouting power—or both. Working with the ISS Program and engineering experts, SPARTAN will continue to maintain the ISS EPS in support of the crew, scientific research, and ultimately exploration.



# Chapter 10 Day in the Life:

## Preparing for the Unexpected



*A close-up of the Node 2 module (center), one of the areas where toxic ammonia can leak into the habitable volume of the International Space Station.*

**At 2:49 a.m. Central Standard Time, a red alarm illuminated the giant front wall display in Mission Control in Houston. The alert read: TOXIC ATMOSPHERE Node 2 LTL IFHX NH3 Leak Detected.**

The meaning was clear. Ammonia was apparently leaking into the Interface Heat Exchanger (IFHX) of the Low Temperature cooling Loop (LTL) in the Node 2 module.

“Flight, ETHOS, I expect the crew to be pressing in emergency response while I confirm,” said the flight controller from Environmental and Thermal Operating Systems

(ETHOS). In other words, the crew needed to don oxygen masks to protect themselves from ammonia while ETHOS looked more closely at these data.

This was not a drill. When the red alarm appeared, the flight director turned her full attention to ETHOS. The words—unwelcome at any time from ETHOS—were especially jarring at an hour when the crew and the ground were humming along on a busy day of running experiments. Of the many failures for which the flight control team prepares, especially in simulations, this failure presents one of the most

life-threatening situations, and one the team never wants to encounter on the actual vehicle.

On January 14, 2015, this scenario happened on the International Space Station (ISS). Data on the ETHOS console indicated toxic ammonia could be bleeding in from the external loops, through the water-based IFHX, and into the cabin (see Chapter 11). Software on the ISS immediately turned off the fans and closed the vents between all modules to prevent the spread of ammonia. At the sound of the alarm, crew members immediately began their memorized response of getting to



the Russian Segment (considered a safe haven, since that segment does not have ammonia systems) and closed the hatch that connected to the United States On-orbit Segment (USOS). They took readings with a sensitive sensor to determine the level of ammonia in the cabin. The flight control team—especially the flight director, ETHOS, and the capsule communicator (CAPCOM [a holdover term from the early days of the space program])—waited anxiously for the results while they looked for clues in the data to see how much, if any, ammonia was entering the cabin. Already, the flight director anticipated multiple paths that the crew and ground would take, depending on the information received.

No ammonia was detected in the cabin of the Russian Segment. At the same time, flight control team members looked at multiple indications in their data and did not see the expected confirming cues of a real leak. In fact, it was starting to look as if an unusual computer problem was providing incorrect readings, resulting in a false alarm. After looking carefully at the various indications and starting up an internal thermal loop pump, the team verified that no ammonia had leaked into the space station. The crew was not in danger. After 9 hours, the flight control team allowed the crew back inside the USOS. However, during the “false ammonia event,” as it came to be called, the team’s vigilance, discipline, and confidence came through. No panicking. Only measured responses to quickly exchange information and instructions. Hearts were pumping rapidly, yet

onlookers would have noticed little difference from any other day.

A key to the success of the ISS Program is that it is operated by thoroughly trained, well-prepared, competent flight controllers. The above example is just one of many where the team is unexpectedly thrust into a dangerous situation that can put the crew at risk or jeopardize the success of the mission. Both the flight controllers and the crews, often together, take part in simulations. Intense scenarios are rehearsed over and over again so that when a real failure occurs, the appropriate reaction has become second nature. After these types of simulations, team members might figure out a better way to do something, and then tuck that additional knowledge into their “back pocket” in the event of a future failure. Perhaps the most famous example of this occurred following a simulation in the Apollo Program. After the instructor team disabled the main spacecraft, the flight controllers began thinking about using the lunar module as a lifeboat. When the Apollo 13 spacecraft was damaged significantly by an exploding oxygen tank, the flight control team already had some rough ideas as to what they might do. Since the scenario was not considered likely owing to all the safety precautions, the team had not developed detailed procedures. However, the ideas were there.

This chapter takes the reader into parts of a simulation to illustrate how the process really works. Material from Chapters 11 and 19 are heavily referenced in this section.

## Training

By the time a flight controller is ready to sit in the Front Control Room, he or she has already undergone years of training. Generally, the team is made up of engineers. Positions and degrees are highly correlated (e.g., an electrical engineer supports the power systems, a computer scientist might support the computer systems); however, this configuration is not strictly required. Math and English majors, and even astronomers, serve as flight controllers. Initial training provides general knowledge of spaceflight operations, the vehicle, visiting spacecraft, the NASA organization, how to work with international partners, and even how to conduct meetings. Flight controller trainees participate in computer-based training and classroom lessons, as well as read manuals and instruction books. After initial technical expertise is achieved, the flight controller in training takes lessons on a Flight Controller Part Task Trainer (Figure 1). These small simulators mimic the telemetry generated for an individual system in a stand-alone fashion. A Station Power, ARticipation, Thermal, and ANalysis (SPARTAN) trainee, for example, will focus exclusively on power system displays and telemetry. This allows the student to see how his or her system will respond to commands or failures. For example, the trainee may execute a procedure while seeing how the real vehicle (i.e., the ISS) will react.

Once the basic system knowledge is mastered, the flight controller starts supporting mini simulations (mini sims) as a team (Figure 2). In a mini sim, most of the ISS core functions



Personal photo courtesy of Robert Dempsey

**Figure 1.** A student using the Part Task Trainer simulator. The student's displays and data will mimic the real ISS in his specific system.

are simulated by computers. The team works through various short scenarios (usually failures) to learn how to communicate crisply, resolve problems quickly, and to determine how to resume a particular task or mission. For example, a power failure in the electrical system will unpower equipment used by all the other systems. In the mini sim, the team will learn to identify the signature and communicate a recovery plan with the flight director, who might actually be an instructor playing the role.

After mastering this, the students will support full integrated simulations, where the purpose is to stay on the timeline as everything possible fails—on purpose. While operators rarely see the same level of failures on the



Personal photo courtesy of Robert Dempsey

**Figure 2.** A team of operators practice working as a team in a mini sim. The instructor (far left) runs the simulation while also playing the role of the flight director, CAPCOM, ISS crew, and international partners.

real vehicle, this training teaches the flight controllers how to work as a team to solve problems often never anticipated, and how to work under pressure. While the flight controllers will learn the signature and responses of specific failures, the simulations also train them to approach a problem, should they not understand the signature they are seeing. More often than not, real failures in space are not anticipated or completely understood when first encountered. In the ammonia leak case discussed above, the failure that caused the signature was never anticipated. In fact, it was believed to be a failure mode that was not even credible or likely. Therefore, the team had to decipher the unusual signature in their data and figure out what to do in real time.

An instructor, a senior flight controller in the group, or the student's manager will evaluate each student through every phase. Several key areas are reviewed. One area is that of problem recognition. Identifying a failure and its impacts, especially within another system, can be difficult with complex systems and a large amount of data. Known failures have clear alarms, but what could have caused a box to fail may require some sleuthing. Other areas include mission cognizance (how the flight controller fits the failure into the bigger picture), communications, console management (how team members organize their data, logs, tools, and displays), and team interactions (either with other flight controllers or their own back room support). Even the student's attitude is evaluated since someone who gets easily stressed or discouraged is not a good person to have on the team.

After successfully completing the simulations and passing an evaluation by the flight director, the flight controller begins sitting on console under the watchful eye of an experienced operator in what is called on-the-job training. When the flight controller is considered ready, the "training wheels" are removed and he or she is certified as an operator—i.e., the first level of certification. That person can perform routine duties on console and respond in an emergency. For all systems except ETHOS, this generally means verifying that the software has reconfigured the systems automatically in response to the failure and then notifying an expert of the situation to obtain further direction. For ETHOS, the operator also supports the three big emergency responses on the ISS—fire, atmosphere leak, and toxic chemical spill—by leading the crew and flight control team through the associated procedures (see Chapter 19). For serious failures or complex operations, a more-senior controller (i.e., a specialist) who has undergone additional training and certification will support the console. Since training is so critical to the success of operations, the trainers (i.e., instructors) are part of the operations group and even support the console positions. This blending of operator/specialist/instructor ensures training is as accurate as possible. Once certified, flight controllers, instructors, and flight directors all must continue to perform proficiency training and evaluation to ensure they remain at peak performance levels. Flight directors are generally selected from seasoned flight controllers. As of December 2015, 91 individuals have been certified NASA flight directors.

After all the generic training is complete, the controllers may be assigned to specific missions, such as an assembly mission (during the Space Shuttle era), a visiting vehicle (Soyuz or cargo flight), a software uplink, or a spacewalk. The assigned team will generally conduct flight-specific simulations in that unique timeline or activity. Complexity of the timeline determines the number of simulations, with the shuttle assembly missions having been on the high end with about a dozen, not counting numerous ascent and entry simulations with the crew.

To illustrate the nature of this critical training, this chapter walks the reader through parts of a particular training session. The following is the transcript of real voice loop data in the Mission Control Center (MCC) recorded on April 24, 2013, during a generic simulation.

Approximately 1 hour prior to the start of the event reflected in this transcript, the US Lab 1 Multiplexer/DeMultiplexer (LA-1 MDM) experienced a failure such that it could no longer pass data to the Primary Command and Control MDM (see Chapter 5). Many impacts to the loss of communication to the LA-1 MDM occurred. A particularly important impact was that almost all insight into the performance of the LTL, which provided cooling to critical internal systems within the Laboratory Module, was lost (see Chapter 11). The Lab thermal system can be operated in dual mode or single loop. In dual mode, the LTL and the Moderate Temperature Loop (MTL) operate independently, each with its own pump. In single loop, the two segments are joined,

and one pump—either the Moderate Temperature (MT) or the Low Temperature (LT)—pushes fluid around the entire system, which is called Single MT or Single LT, respectively. This is significant because, at the time of the failure, the US Lab internal active Thermal Control System (TCS) was in Single LT mode, meaning one water pump on the LTL was performing all of the heat transport of cooling water to US Lab systems. The LTL pump remains running in the event of an LA-1 MDM failure as several key pump performance parameters are being reported to and controlled by a different MDM. However, loop pressure, flow, temperatures and, most importantly, pump accumulator quantities, are lost. The pump accumulator quantity is especially important because a sudden decrease in accumulator quantity indicates that cooling water is leaking out of the system. If the leak is not stopped, enough water will be lost to cause the cooling loop to fail and critical equipment to overheat. A sudden increase in accumulator quantity indicates that another fluid is being injected into the system. Given the way in which the internal cooling loop is plumbed, the only possible fluid that could be injected into the system is the 100% anhydrous ammonia that is used as a coolant for ISS external systems. The ammonia and water come into thermal contact to exchange heat, but are kept separate from each other at the IFHX (see Chapter 11). This grade of ammonia is fatal to humans, even in small quantities. Also, one of two redundant Internal Audio Controllers (IACs), which route all on-board voices to different destinations, failed prior to the simulation start in

what is known as an initial condition of the simulation. Another initial condition was that the External TCS (ETCS) Loop B experienced a transient failure, which shut the pump down.

## Communications

One of the most critical skills that a flight control team needs to exercise is communication. Owing to the complicated, often time-critical nature of spaceflight, a specific shorthand and cadence was developed to facilitate communication between the various controllers, the flight director, and the crew. Flight controllers in Mission Control communicate over loops, which is nothing but a dedicated phone line, so to speak, between parties. Typically, each person must listen to more than a dozen of these voice loops at the same time. Using a headset, a flight controller plugs into the system to hear the calls that are defined on a computer panel. There are literally thousands of loops from which to choose, but each person usually monitors only a small subset. Conversations can occur simultaneously on all the loops during busy times. Sometimes the flight controller needs to follow along with only a few, but at other times he or she may need to directly participate in the discussion. Learning to process all these simultaneous conversations is a key skill the flight controllers have to master.

Calls between controllers begin with the name of the person being called, followed by the position that is making the call. For example, “SPARTAN, CRONUS on SYS COORD” indicates that

the SPARTAN controller is calling Communications Rf Onboard Network Utilization Specialist (CRONUS) on the voice loop called SYS COORD, which stands for Systems Coordination. When CRONUS hears this, he or she will talk directly to SPARTAN. The most critical loop is the FLIGHT loop, which is owned by the flight director. In a real sense, this is the “king” of loops and everyone in every control center around the globe always has to monitor this critical loop. The only other special loop is the Space-to-Ground (S/G) loop. Only the CAPCOM talks to the astronauts on this loop. Since an astronaut’s time is so critical and communication can be limited, everyone is required to stop talking during a call from the CAPCOM to the astronauts, or vice versa. This prevents the ground from talking over and therefore missing an important item, or making it necessary for the crew members to repeat themselves.

A key part of this communication training is to learn how to talk concisely. Unlike an office meeting where employees can take all the time necessary, discussions in Mission Control are usually time critical. If the discussions are not time critical, they are still kept to a minimum since everyone is monitoring multiple loops. Another way to keep communications crisp is to add a brief phrase to explain why the person is calling. This is indicated by stating “for” followed by what the call is about, thus allowing the receiver to prioritize and prepare for the discussion. Following is an example of a simple exchange during that simulation. NOTE: The transcript has been edited for readability. The

italicized information within the square brackets helps explain or clarify what is going on or what is meant by a particular acronym, word, or statement, but it is not part of the actual transcript.

CRONUS: FLIGHT, CRONUS, for the IAC. *[This is CRONUS calling the flight director about the previously failed IAC. Since the FLIGHT loop is the key loop, its name generally does not need to be used.]*

FLIGHT: CRONUS, FLIGHT. *[The flight director is acknowledging the call and indicating that she is ready to talk to the CRONUS operator.]*

CRONUS: Yes, FLIGHT, so when we saw the IAC failure, we were initially on IAC 2. Audio FDIR *[Failure Detection Isolation Recovery, an automated recovery algorithm, see Chapter 5]* swapped us over to IAC 1. That swap was not successful, and then it brought us back up on IAC 2. So in order to clean up and recover voice, I ran Ground Avionics procedure 2.311, just blocks 1 and 2 which basically covers inhibiting Audio FDIR and reconfiguring *[voice loop configuration]* calls. I'd like to continue to press through that procedure. Normally you'd run this procedure to power up the failed IAC and check it out but since we started up on IAC 2 and it looks healthy, since we are back on IAC 2 now, I'd like to actually power up IAC 1, which is the one we weren't able to recover on, and see if I can see any issues with that.

FLIGHT: Ok, I concur, you're go.

CRONUS: Copy. *[Shorthand for "I hear and understand you."]*

SPARTAN: FLIGHT, SPARTAN, for status.

FLIGHT: SPARTAN, FLIGHT. *[i.e., "Go ahead, I'm listening."]*

SPARTAN: FLIGHT, the pump is back up and running. At this point I am ready to re-integrate the interface heat exchangers *[the automated response from an external pump failure is to isolate the external ammonia loop from the heat exchangers that transport heat from the internal water cooling loops in the various modules to the external ammonia loops]*, beginning with Node 2, Node 3, IPs *[referring to the Japanese and European ISS modules]*, then Lab.

FLIGHT: I'm sorry, say again, pump is running, then what?

SPARTAN: The loop Bravo pump is up and running, at this point I am ready to re-integrate the interface heat exchangers, beginning with Node 2, going to Node 3, then the IPs, then the Lab.

ETHOS: And FLIGHT, ETHOS, I copy, and whenever the heat exchangers are re-integrated a lot of times we get a little bit of overshoot, and there's a potential for some undertemp *[i.e., too cool]* messages on the board but that should level off pretty quickly. There'll be no action *[by crew or ground]* for those once we are integrated.

FLIGHT: Copy.

*[Shortly after SPARTAN completed his commanding, a caution-and-warning message was displayed to the ground and the crew about an undertemp in the TCS]*

ETHOS: And FLIGHT, ETHOS that enabled caution was what I was talking about, no action for the crew.

CAPCOM *[on the S/G-1 loop]*: Station, Houston, on 1, no action for the TCS caution. That was expected.

ISS CREW *[on the S/G-1 loop]*: Copy Houston, no action for the TCS caution, thanks.

## The People Behind The Curtain

The simulator—basically a series of computers that can emulate the behavior of ISS systems and the space environment—is a powerful tool. When a student is in the training control room, the data on his or her computer screen or console will look exactly like it would if it were the actual space station in orbit. SPARTAN, for example, can watch the solar arrays rotate as sunlight is converted to electricity and routed around the ISS until the station orbits into the Earth's shadow and the batteries begin supplying all the power needed. With the flick of a wrist, the simulation team can fail a bus or converter. However, the key to the simulation is the training team that operates it. This team is led by the Chief Training Officer (CTO), who is essentially the flight director of the training world.

Scenarios developed by the training team depend on the type of simulation being conducted. As the name implies, generic simulations focus on general skills of the team—i.e., communication, coordination, and problem resolution. In these types of simulations, the training team will induce a failure that impacts multiple systems. For example, a power bus may fail, which can affect every other group. Due to the robust redundancy of most ISS systems, these types of failures usually result in the flight control team learning how to reconfigure the operating systems (e.g., activating the redundant unit), troubleshoot the failed one, and recover the failed system, if possible (e.g., reboot the computer if that is the issue). At all times, the team must try to keep the planned events



Personal photo courtesy of Robert Dempsey

**Figure 3.** The training team, led by CTO William Frank (green shirt) in their own Mission Control-like facility. A computer generates the fake ISS data that the flight controllers see in Mission Control. The training team is also looking at these fake data. However, unlike the flight controllers, the instructors can inject failures into the simulation at the stroke a mouse click. For example, they can make a pump suddenly overheat and fail, or make a computer start generating erroneous messages.

(e.g., the spacewalk) continuing as scheduled. Flight-specific simulations are focused on a particular upcoming event wherein the actual team members who will execute the event train together. Generic simulations are populated with people at various levels of training.

Failure scenarios can become fairly complicated. One or two system failures may not be much of an impact to the operations; however, they can combine to cause significant constraints or vulnerabilities to an additional failure. For example, consider a module that has two internal thermal control loops and two power strings: A and B. Thermal pump A is on power string A; thermal

pump B is on power string B. If power string A fails, string B is used. Now, thermal pump B becomes more critical. Should anything happen with the thermal loop (e.g., the pump fails) or if power string B is interrupted, all cooling to that module will be lost. In this type of scenario, the team will try to anticipate the next-worse failure after the first failure. Thus, when string A goes down, the team will try to anticipate what to do to best protect the vehicle for the next failure. In this example, the team might get a power jumper ready to reactivate pump A by plugging it into the B system.

The training team spends a significant amount of time learning the systems, the timeline, and the objectives in

preparation for a simulation. This research may involve going into the simulator, testing failures, and seeing how the software responds. Not only does this help lead to a realistic simulation, on many occasions real software bugs have been caught before being loaded onto the actual vehicle. Several weeks in advance of a simulation, the CTO will lead development of a script for the run. The script defines what failures will occur, and when and what the training team anticipates the flight control team will do in response. Sometimes, however, the flight control team will make a decision, either in error or on purpose, and choose a different response than anticipated. In this case, the training team will conduct

the rest of the simulation “on the fly,” adapting to the team. In cases where the flight control team has not realized the impacts of some failures, the CTO will call for inserting that very failure for the purpose of driving home the lesson of missing these types of cases. Such was the case on the April 24 simulation, when the CTO decided to drive home the criticality of the problem with the LA-1 MDM that the inexperienced flight controllers were missing.

The training team will continue to stack failures to force the team to think of options and prepare for the next failure. In a simulation (Figure 3), another failure will always occur. By being constantly hit with numerous failures, the flight controllers can see how the interconnectedness of the systems works. Students also become confident and comfortable around the failures so that when they happen on the real vehicle, they can say, “I know this.”

ETHOS: *[ETHOS is leading the team in procedure 4.111 ECLSS (Environmental Control and Life Support System)/ITCS (Internal Thermal Control System)/PTCS (Passive Thermal Control System) RECONFIGURATION FOR LAB1 MDM TRANSITION OR FAILURE.]* In my mind the next critical item would be step 2.3, moding my Lab ITCS *[Internal TCS]* to Single MT *[the MT loop running with a single pump]* because in the current state right now we’re basically buying into the risk of a next failure, we don’t have any leak detection, for both ammonia and water leak detection.

FLIGHT: Ok, so do you want to go ahead and execute that step before you assess the LA-1 MDM failure?

ETHOS: FLIGHT I don’t think the conversation will take too long, about our forward path, whether we just troubleshoot really quick or stay in this configuration.

FLIGHT: Alright, you have a couple minutes.

ETHOS: Copy FLIGHT.

CRONUS: FLIGHT, CRONUS, for IACs.

FLIGHT: CRONUS, FLIGHT.

CRONUS: Yeah FLIGHT my command was not successful so I’ve powered off IAC 1, and I’m thinking about why we got that signature when we powered it up.

FLIGHT: Ok, ETHOS and CRONUS, LA-1 MDM, you guys are talking about it, so what’s the thought on it?

ETHOS: Alright FLIGHT, so, yes, I have discussed this a little bit with my specialist as well, and I tagged up with CRONUS, and my recommendation right now is that we hold off on any type of trying to regain the LA-1 MDM right now and I will just put the rest of my steps per that 4.111 procedure in work. My rationale here is that my Lab P6 CCAA *[Laboratory Port 6 Common Cabin Air assembly]*, the one that’s associated with this MDM is still running, however I have no insight into it, if we do the troubleshooting it would take my CCAA back down and if we’re not successful with it that CCAA down. That currently is the CCAA that is having condensate collection and we normally like to dry out our CCAAs before we shut them down. So after I configure all my stuff to safe with the LA-1 down, I would work a plan to try and swap that condensate over to another module, most likely we’d like the condensate to condense in Node 3. So, those are the actions I’d look for, and swapping the condensate takes a little while. So, there’s that action, as

well as, we’d eventually like to do that anyway, to get on our S6 CCAA to have good insight into it.

FLIGHT: Ok, understand.

CRONUS: FLIGHT, CRONUS.

FLIGHT: Ok, so at that point ETHOS, when you do all that reconfiguration, you’d like to CRONUS to do the LA-1 MDM troubleshooting?

ETHOS: Yeah, as soon as we get condensation, and we’re comfortable, making sure that that CCAA is dry.

FLIGHT: Ok, understand.

ETHOS: As far as impacts, if for some reason we get forced our hand we can do it earlier, it’s not the worst thing in the world, but..

FLIGHT: And so, what’s the estimate time for that? A shift, two shifts, how much time do you need for all that?

ETHOS: I would say at least the rest of my shift and *[the next]* shift FLIGHT, and if we can withstand holding off any troubleshooting till tomorrow that would be plenty of time to make sure we’re dried out on that Lab CCAA.

FLIGHT: Ok, CRONUS, your input?

CRONUS: Yeah, FLIGHT, CRONUS, I concur with ETHOS’s recommendation. There isn’t a rush to powercycle *[rebooting a computer often can recover it just as on the ground with a laptop or desktop]* the LA-1 MDM. We need to look at it a little bit more obviously we don’t want to be running in this configuration with the MDM in Min Ops without any insight into it indefinitely, but if it, we’re definitely fine with it staying here in order for him to get into configuration. *[Min Ops, or Minimum Operations, is a mode of the MDM that keeps it running some basic functions even though it is not receiving direction from the computer above it.]*

FLIGHT: Ok, in the meantime do you already know what your troubleshooting plan would be, or...

CRONUS: Yeah FLIGHT with it being loss of comm [*meaning the Internal MDM cannot talk to the LA-1 MDM*] the only thing we can do is to try to power cycle the MDM. I don't have the specific procedures for you yet but I can get those for you if you'd like and put the whole plan together in a flight note [*a text document that can be read and reviewed by the entire team*].

FLIGHT: Yeah let's go ahead and get that in work so that you have another shift to take a look at it.

CRONUS: Wilco. [*Short for "will comply."*]

## The Emergency

The team works through various failures for several hours (Figure 4). Each failure represents a singular problem for that particular flight controller and his or her system. The flight director, however, keeps track of all the failures and pays close attention to the overall picture with the goal of trying to complete the planned activities with minimal impact. While each controller may be dealing with one or two individual problems, the flight director is tracking issues with six to nine systems. Flight's role has often been compared to the Chinese acrobat balancing spinning plates on long sticks. However, as challenging as these individual failures are, the most-critical issues facing the team are these emergencies: fire, rapid depress, and toxic atmosphere (see Chapter 19). Therefore, the trainers frequently push the team further with a major emergency, often after an exhausting round of

system failures. After several hours, the situation turned very serious when an emergency alarm—TOXIC ATMOSPHERE – MANUAL ALARM – LAB—appeared, in red, on the big caution-and-warning display in the front of the control room. This meant the crew detected a toxic spill, possibly ammonia, in the Laboratory module.

ETHOS: FLIGHT, ETHOS, I see the toxic atmosphere alarm.

CAPCOM [*on the S/G-1 loop*]: Station, Houston, on 1, we see a manual toxic atmosphere alarm, can we get a status when you can? [*No response from the crew.*]

ETHOS: FLIGHT, ETHOS.

FLIGHT: ETHOS?

ETHOS: Like I said my Lab ITCS due to the LA-1 MDM, I have lost insight into any type of potential ammonia leak. In this case FLIGHT I'd expect that the crew is doing their emergency response but for the team here on the ground we're going into EMER-1 [*the initial emergency response procedures, also known as the "Red Book"*] procedure 3.3.

CAPCOM [*on the S/G-1 loop*]: Station, Houston, Space to Ground 1, we assume you have pressed the manual alarm button for an ammonia release, and we are in 3.3, Emergency 3 decimal 3, for ammonia release. That is our assumption.

CRONUS: FLIGHT, CRONUS.

FLIGHT: CRONUS, FLIGHT.

CRONUS: I'd like to get a go for emergency comm config [*shorthand for communications configuration, this procedure ensures that all voice loops can be heard in as many ISS modules as possible*].

FLIGHT: You're go.

CRONUS: In addition I'm going to work on bringing up the PTR [*Port Thermal Radiator*] MDM as SPARTAN could need it for emergency response. [*The PTR MDM is required if the SPARTAN has to lock the arrays in a specific position.*]

FLIGHT: Concur.

ETHOS: FLIGHT, ETHOS.

FLIGHT: Go.

SPARTAN: SPARTAN concurs.

ETHOS: FLIGHT, ETHOS.

FLIGHT: Go ahead.

ETHOS: There's an action I want to do anyway but I'd like a go to transition my Lab ITCS to Dual [*mode*]. I'll get better insight.

FLIGHT: You're go.

ETHOS: Copy FLIGHT.

FLIGHT: Ok, let's see, GC, you can go ahead and call Spacecraft Emergency. [*This is a protocol that the Ground Controller (GC), who is responsible for the MCC infrastructure as well as interface to the NASA Space Network, invokes with the Space Network to make sure the ISS gets all available satellite communications assets and bumps other users from using those assets.*]

GC: FLIGHT, GC, I copy.

CRONUS: FLIGHT, CRONUS, emergency comm config is in place.

FLIGHT: Copy.

ETHOS: And FLIGHT, ETHOS, I do see a positive DP/DT [*shorthand for delta atmospheric pressure increasing over delta time, meaning something is coming into the pressurized volume*]





**Figure 4.** A team of operators performs a simulation (different than the one discussed in the text) under the direction of Flight Director Courtenay McMillan (Tranquility Flight, bottom left). The simulation control room, formerly used for conducting Space Shuttle missions, is set up exactly like the main ISS flight control room (see Introduction).

into the cabin, so this is an ammonia leak, it is leaking into the US Segment.

GC: Two minutes to a TDRS handover. [This means that link with the Tracking and Data Relay Satellite (TDRS) is swapping from one satellite to another as the ISS orbits the Earth, and there will be a brief loss of communications until the radio link is established on the other satellite. During an emergency, it is critical for the team to understand

when the ground does or does not have a communication link with the ISS.]

ADCO: FLIGHT, ADCO per rule B2-359 we need to enable auto-handover to the Russians. [The Attitude Determination and Control Officer (ADCO) is quoting a flight rule that indicates that if there is a chance the gyroscopes will not be able to maintain the control of the ISS, "auto handover" should be enabled. Auto handover

is the process by which the US and Russian attitude control systems can take and give control to each segment. In the case of an ammonia leak into the cabin, an action that the team can take to mitigate danger to the crew is to vent the ammonia in the external loops overboard, which is a sufficiently large enough propulsive force on the ISS that the US control moment gyroscopes cannot maintain attitude control and, therefore, Russian thruster control

## “Well that can’t be right . . .”

### Captain Barry “Butch” Wilmore, Expedition 41 and 42

“It was January 14, 2015. There I was in the corner of Node 2, completely focused on the highly classified and highly volatile secret government experiment attached to the Maintenance Work Station before me, when all of a sudden . . .”

If I were writing a novel or memoir, I might take the liberty to embellish the details a bit, as I did in the preceding sentence. Instead of working on a “highly volatile secret government experiment,” however, I was floating in the overhead of Node 2, digging through a 1.0 cargo transfer bag where my excess clothing was stored, trying to find some clean skivvies—that’s Navy speak for underwear—when all of a sudden . . .

OK, it wasn’t sudden either. It was just the emergency warning tone. I say “just” because we’d had several of them in the preceding days. All of the warnings turned out to be false alarms as several of the highly sensitive sensors, which detect smoke in both the Russian Segment and Node 3, had annunciated. None of them had actually been smoke or fire—just dust kicked up by work that was taking place in the vicinity of the sensors.

As the current station commander, I reminded the crew that one false alarm, or even several, does not mean that the next one will be false too. We had to maintain our vigilance and treat every emergency as real, and keep stepping through our memorized procedures. With this in mind, when the tone annunciated *waaank whoop waaank* (it’s difficult to describe a tone on paper), I stuffed my skivvie bag back into my clothing cargo transfer bag and quickly floated to the emergency panel, where I expected to see another “Fire” caution light. The only other lights are: “ $\Delta P/\Delta T$ ”, which is short for cabin depress or leak; and “TOX”, which is short for an ammonia leak (Chapter 19).

On Earth, a bit of ammonia in cleaning solution disinfects and helps get rid of tough kitchen stains, leaving that clean smell. The ammonia on station, however, interacts

with water loops, which cycle inside of station and pick up heat. The loops then transfer that heat into the ammonia that flows to radiators on the outside of station, which dispel the heat into the vacuum of space (Chapter 11). The smell of ammonia, which should be outside the station, means it has found its way inside the station. Even brief exposure could mean returning to Earth as special cargo rather than as a crew member. Thus, when I finally focused on the emergency panel and saw “TOX” illuminated, my initial thought was, “Well, that can’t be right. We’ve never had that emergency on the ISS because that means . . . ammonia!” That thought lasted about a nanosecond as the next thing I knew I was yelling, “Masks!”

Without any of us even being aware, the training we’d gone over and over and over for years kicked in. Russians don’t use ammonia to dispel heat, so if we could get there and close the hatch, we could isolate ourselves from the potential toxic environment brewing in the US Segment. With protective mask in place, I grabbed two of my incapacitated crew members, quickly put masks on them, strapped them to my back, and continued translating toward the Russian Segment . . .

OK, I didn’t do that either. Each crew member immediately donned protective masks and began translating toward the Russian Segment, thus implementing the memorized response.

Via procedure, I ensured all personnel were on the Russian side of the Node 1 Aft Hatch before beginning the process of closing the hatch and thereby isolating ourselves from the US On-orbit Segment. As I locked the hatch closed, I remember peering through the small window in the center of the hatch and thinking, “I wonder if we’ll ever go back in there again.”

*is required. As part of the normal process of using the powerful Russian thrusters, the US Solar Alpha Rotary Joints (SARJs) need to be locked into a specific position to prevent structural damage to the large arrays.]*

SPARTAN: FLIGHT, SPARTAN I'll need to park my SARJs.

FLIGHT: You're go to park SARJs.

ETHOS: FLIGHT, ETHOS. *[Looking for a status.]*

ETHOS: FLIGHT, ETHOS my Lab ITCS is currently trying to transition to dual, I would have expected it to come back up already in Dual by now but that didn't work. I'm still assessing why that is, but for the crew, it is the ammonia response in 3.3, they'll be taking readings in the *[Russian Segment]* and they'll be reporting that in step 8. If concentrations are high... and FLIGHT I see that warning *[an additional red warning alarm appeared on the screen]*, that's from the Lab ITCS, that transition didn't work. I'll troubleshoot that in a second, but for the crew, they should be calling, like I said, in step 8, their readings. If it's high basically they're going to go to step 9 and they're going to go to the Soyuz and try to establish a clean zone in the Soyuz. If it is low, they're going to go to step 18, and they're basically going to try to wait, about 2 and a half hours, until they can scrub all that, and they'll take continual readings...

FLIGHT: Copy.

SPARTAN: FLIGHT, SPARTAN, SARJs locked.

FLIGHT: Copy, SARJs locked.

ADCO: And FLIGHT, ADCO, auto handover to the Russians is enabled. *[This means that if the USOS loses the*

*Control Moment Gyro attitude control of the station, the Russian thrusters will automatically take over controlling the vehicle orientation.]*

FLIGHT: Copy.

*[FLIGHT confirmed this configuration with the Russian shift flight director on the MCC-M to MCC-H coordination loop. The Russian flight control takes part in the training as well.]*

CAPCOM *[on the S/G-1 loop]*: Station, Houston, Space to Ground 1, for a status.

FLIGHT: CRONUS, FLIGHT.

CRONUS: FLIGHT, CRONUS.

FLIGHT: Are public calls good for the crew to call down?

CRONUS: Good on the Russian Segment, yes.

FLIGHT: Ok.

CAPCOM *[on the S/G-1 loop]*: Station, Houston, Space to Ground 1, for a status.

SPARTAN: FLIGHT, SPARTAN, for interface heat exchangers.

FLIGHT: Go ahead.

SPARTAN: FLIGHT since we cannot determine which side the leak is on I can close both sets of interface heat exchangers. This would remove heat rejection from all modules. *[By shutting down the pumps, there will be less pressure potentially pushing ammonia into the cabin since the team is not sure where the leak is located; however, this means the thermal loops will not be able to remove heat from the systems.]*

FLIGHT: Ok.

ETHOS: FLIGHT, ETHOS.

FLIGHT: ETHOS, FLIGHT.

ETHOS: That's going to remove cooling, like he said, so let me try one more command to go to Single MT, to see if I can pick this back up and determine which side the leak is on.

FLIGHT: Alright, so...

ETHOS: And if not I think that would be the forward action to bypass those.

FLIGHT: Alright, you probably have a minute or so. I don't want to spend time.

CAPCOM *[on the SG-1 loop]*: Station, Houston, Space to Ground 1, for a status.

ETHOS: FLIGHT, ETHOS, I successfully went over to single MT, and I'm taking a look at my data to assess to see where this leak might be.

CAPCOM *[on the S/G-1 loop]*: Station, Houston, Space to Ground 1, status.

ETHOS: FLIGHT, ETHOS.

FLIGHT: Status?

ETHOS: Yes FLIGHT, I swapped over to Single MT, now I have insight into the entire Lab system, its one loop...

FLIGHT: Can you confirm by pressures that they've closed the hatch between the two segments?

ETHOS: Yes FLIGHT let me confirm that.

ETHOS: FLIGHT, ETHOS, I cannot confirm that hatch closure between Russian Segment and US Segment right now, the pressures on the Russian Segment are very close to an in-family with the US Segment.

FLIGHT: Ok.

FLIGHT: All right so ETHOS you see the quantities in the accumulator increasing...

ETHOS: That's right FLIGHT and because it's a single loop I still cannot tell if it is associated with Loop Alpha or Loop Bravo. I recommend that just isolate those and vent those ETCS loops. *[The flight controllers use the phonetic alphabet to prevent misunderstandings. Here 'A' and 'B' are called Alpha and Bravo.]*

CAPCOM *[on the S/G-1 loop]*: Station, Houston, Space to Ground 1, for a status, when available.

ETHOS: And that procedure FLIGHT only has paths where we go to Dual and I figure out which loop it is on. I'm still... I don't know if we have a... I'm taking a look at my procedures to see if we have one that covers this specific case...

FLIGHT: Can we even get back to Dual?

ETHOS: Let me think about that FLIGHT.

GLAVNI *[This is the spacecraft communicator in MCC-Moscow, translated into English, on the S/G-1 loop]*: Station, this is Mission Control Moscow on Space to Ground 1, can you read us?

GC: FLIGHT, GC.

FLIGHT: GC, FLIGHT.

GC: FLIGHT the gaps have been filled for the next 24 hours. *[This means that any gaps in the planned communication schedule with the ISS using the TDRS network have been filled but are forcing other users of the system off due to the spacecraft emergency.]*

SPARTAN: FLIGHT, SPARTAN, Lab interface heat exchangers bypassed and isolated.

FLIGHT: Copy.

ETHOS: FLIGHT, ETHOS.

FLIGHT: ETHOS, FLIGHT.

ETHOS: In the current situation that I can't tell which ETCS loop it's associated with I would recommend venting both loops. I'm basically doing this to try to keep the structural integrity of the Station. We do have PPR *[Positive Pressure Relief, which kicks off when the internal pressure of the ISS is too high, vents some atmosphere overboard. However, this venting can produce a thrusting force that can cause the ISS to tumble out of control. This is why ADCO wants to make sure the Russian Segment's power thrusters are ready to take control via auto handover]*. However, we will hit that in about 30 minutes or so, there is one thing I could do I could try and mode back to Dual, I would expect it to work but of course it failed the first time too and I'm not exactly sure what caused that, if it is LA-1 induced, however I would think that it would still mode to Dual. Now that we are in Single MT it might work again.

FLIGHT: Once we get to Dual can we actually vent both loops from that configuration with LA-1 MDM not available?

ETHOS: That would be a SPARTAN's call, if LA-1 affects that, I don't believe it does.

SPARTAN: It does not, FLIGHT.

ETHOS: Going to Dual, FLIGHT, would just let us know which one it's associated with.

FLIGHT: Does it matter at this point? Which one it is?

ETHOS: FLIGHT when you vent an ETCS loop you can't regain it so we're basically calling it quits on the ETCS loops and basically all the US Segment. We do have a ton of ammonia in there anyway so I'm just worried about safing

the situation right now, so that's why I would recommend venting both loops, since I cannot tell.

SPARTAN: And SPARTAN concurs with that.

FLIGHT: All right how many commands is it to go back to Dual?

ETHOS: Two.

FLIGHT: All right send us back to Dual.

ETHOS: Copy FLIGHT I'll put it in work.

FLIGHT: Quickly.

FLIGHT: SPARTAN do you have anything to suggest which loop you want to vent? First, anyway?

SPARTAN: And FLIGHT I have no insight into this. From a venting standpoint, both loops are redundant; we would just need to pick the right loop to vent. Once we vent the loop it cannot be...

FLIGHT: Ok, understand.

FLIGHT: ATAs *[Ammonia Tank Assemblies, which can be used to refill a cooling loop]* on orbit, right? We have ATAs on orbit?

SPARTAN: We do have the ATAs, FLIGHT.

FLIGHT: I'm more worried about keeping the USOS intact and not having to...

SPARTAN: During the venting process I would be isolating the ATAs and then venting everything in the lines of the ETCS system. The reason that those lines would be damaged at that point is that the lines were never intended to bring water through them, so bringing the water through them, the ETCS lines, could cause permanent damage to them.

FLIGHT: Copy.

FLIGHT: Alright you have your procedure ready?

SPARTAN: I do FLIGHT I'm in 9.19 and 9.20, Loop A, Loop B. I do have one step to park the TRRJ [*Thermal Radiator Rotary Joint, which positions the external ammonia radiators*] for structural integrity...

FLIGHT: Why don't you go ahead and do that.

SPARTAN: Copy.

FLIGHT: And CRONUS you have PTR back up?

CRONUS: I do FLIGHT.

ETHOS: FLIGHT, ETHOS.

FLIGHT: ETHOS?

ETHOS: Okay FLIGHT we are currently moding over to Dual, I will let you know how that goes, additionally I'm still looking at my pressures on Russian versus US segments, I still see the Russian Segment pressure increasing, and I have verified that we have good IMV [*InterModule Ventilation*] closure, between the two vehicles, so that's indicative to me that the hatch is still open.

FLIGHT: Okay let's make a call to the crew to tell them that we are expecting them in the Russian Segment with the hatch between the US and Russian Segment closed, they should be in 3.3 in step 8 to call down those CMS readings [*Chip Measurement System, which can detect airborne concentration of ammonia*].

CAPCOM [on the S/G-1 loop]: Station, Houston on Space to Ground 1, we are expecting you in 3.3 for ammonia release and we are waiting for your readings on step 8. We are also expecting you to be isolated in the Russian Segment with the hatch

closed between the Russian and the US Segment.

ETHOS: FLIGHT, ETHOS for ITCS status.

FLIGHT: Go ahead.

ETHOS: FLIGHT I got the Mode Unknown again, so I'm not....there's no way I can... I can't tell... I cannot basically put this into Dual loop mode, I'm missing something FLIGHT, the LA-1 MDM one of my valves is not transitioning over, so there's no way I can actually split apart. So right now I recommend venting both ETCS loops. We do see it coming into the US Segment, and from what I can tell it's going to be the entire station with equal pressures across the stack. Since we have not heard from the crew I'm pretty worried about the safety there so I'm going to stand down on any type of ITCS configurations and I'm going think about where I'm going to go to try to recover crew.

FLIGHT: SPARTAN, you're go to vent.

SPARTAN: Vent both loops FLIGHT?

FLIGHT: Vent both loops, yes.

SPARTAN: Copy.

ETHOS: FLIGHT, since we haven't heard from the crew at all too I'd like to go ahead and call the entire team into looking at anything in their systems that might give us an idea of where the crew might be... if there's any movement or activity at all on Station.

SPARTAN: And FLIGHT, SPARTAN, just to let you know, my next command for both loops will vent the loops.

FLIGHT: Ok, you're go.

SPARTAN: And FLIGHT, SPARTAN, for the team, both Loop Alpha and Loop Bravo are currently venting.

FLIGHT: Copy, external loops venting.

After some additional time working through the scenario, the call that brings relief to the hard working team is made.

CTO: FLIGHT, CTO, on your loop.

FLIGHT: CTO, FLIGHT.

CTO: Yes ma'am I'd like to call the sim here. 15 minutes, let everybody take a break, come back at 3:30.

FLIGHT: Copy, 3:30.

## The Debrief

When a simulation ends, the team members almost always breathe a sigh of relief. For a number of hours, the team has been running at top speed, diagnosing failures, recovering systems, and pressing ahead on the timeline. But even when the sim ends, the work is not over. The last thing the team does is perform a self-critique—called a debrief—led by FLIGHT and the CTO. During debrief, the team will review the major events, this time with the training team explaining what was really going on. What did the flight control team members do wrong? What could they do better next time? In general, how did they do in terms of problem recognition, mission cognizance, communications, and team management, and how was their attitude? Although each individual flight controller strives to improve his or her performance, these simulations often result in a better way to coordinate, perhaps even including changes to flight rules or procedures.

In the simulation from April 24, the failure that initially appeared minor but played a major role in the rest

of the sim was an issue with the LA-1 MDM. It had not completely died, but instead was still operating; however, the computer circuit that allowed it to talk to its bus controller—i.e., the Internal MDM (see Chapter 5)—was not operating. Thus, the LA-1 MDM still tried to control its pumps and valves, but the rest of the system could not talk to it. This MDM managed the LTL accumulator quantity. Normally, if the liquid in that accumulator increases, it means water from the other loop or from the ammonia line is leaking into the system. Yet, those data could not be reported because of the communication failure with the Internal MDM. However, in this sim case, those data could not trigger an automated alarm. The crew smelled the ammonia and pressed the manual alarm. Since the flight control team failed to fully recognize the configuration and the full implications, the CTO decided to change the sim plan and insert an ammonia leak. By the time a person smells ammonia, there is a significant chance it is too late because of the toxicity. Since the crew is well trained to perform a memorized response, indication that the hatches were not in their expected sealed position followed by the lack of response by the crew when called did not bode well. Yet, no one on the flight control team acknowledged that fact.

Furthermore, the LA-1 MDM controls the Loop Crossover Assembly (see Chapter 11), which allows the thermal loops to be separated into two independent loops (i.e., dual). Since the flight controller did not recognize this issue, the attempts to transition to dual mode were failing. The team lost precious time since this transition was never going to succeed. In some areas, team coordination and communications during this simulation worked well. ETHOS, SPARTAN, CRONUS, and ADCO worked very well with regard to the solar arrays. They realized that if the loops were vented, the ISS could lose gyro control and would need to hand over to the power attitude thrusters of the Russian Segment. Before this could be done, the massive solar arrays had to be put into a safe configuration. This, in turn, required the PTR MDM to be recovered.

Although the team did everything in its power to save the crew, this simulation drove home that mistakes and failures can put crew members at risk or get them killed. Simulations such as this emphasize the need for vigilance, responsibility, and competence to the flight controllers. Lives are in their hands, and this can never be forgotten—not even for a moment. The team repeated many additional simulations so that when faced with a critical event, such as the one that occurred in January 2015, the same mistakes would not happen again.

## Why NASA Trains

The integrated simulation is the capstone training event for every flight controller. A flight controller must demonstrate technical expertise for his or her system before participating in a simulation. Yet, the simulation is where the flight controllers come together as a team. By performing simulations prior to the actual event, teams have been able to avoid numerous problems in space. Teams that had been drilled over and over again by the instructors were better able to handle a given problem, as was the case that early morning in January 2015. The team had practiced ammonia releases many times. What happened on the ISS that day was not a real ammonia leak, but rather a computer failure—one that had heretofore not been known as a possibility. The team had to figure out what was going on. However, the most critical actions—to save the crew and vehicle—were virtually reflexive. While the flight controllers and the flight director often lay awake at night hoping such a day will never come, they know that if it does, they will be prepared.







## Chapter 11 **Systems:**

Thermal Control—  
the “Circulatory System”  
of the International  
Space Station



*A picture of the International Space Station (ISS) showing the largest and most visible portions of the Thermal Control System: the radiator panels. Four white radiators project down in the photo, and provide dedicated cooling to the ISS Electrical Power System. Two sets of three larger radiators project upward in the image, and provide cooling to all the other systems on the ISS. Fluid lines loop through ISS systems, and the coolant within collects heat from computers, electronics, air conditioners, and other mechanical systems around the ISS. That heated coolant then flows through the radiators where the heat is rejected into space, and the coolant, returned to its starting temperature, runs through the same cycle again.*

**Other chapters have explored the “brains” of the International Space Station (ISS), the “lungs,” the ability to “see,” “hear,” and “speak,” and even how its energy is generated.**

Equally important is the “circulatory system” of the space station. As the ISS orbits the Earth, it spends roughly half of each orbit in daylight and half in darkness. Beyond the Earth’s atmosphere is a harsh thermal environment. When equipment in space is exposed to direct sunlight—without the protection of the Earth’s atmosphere—solar radiation can cause severe heating, thereby rapidly increasing temperatures up to 150°C (302°F). When equipment is

exposed to the vast darkness of space, temperatures plunge sometimes as deeply as -130°C (-202°F). The Thermal Control Systems (TCSs) of the ISS perform two important, but seemingly opposite, functions. Fluid systems both inside and outside the vehicle act as a circulatory system, picking up excess heat from around the vehicle and then rejecting that heat overboard, thus maintaining equipment at proper working temperatures. These fluid systems are called Active TCSs (ATCSs), and there are several variations of active thermal systems on the ISS. Conversely, heaters installed throughout the vehicle

protect equipment from freezing in the deeply cold periods of darkness during each orbit. These heater systems are known as Passive TCSs (PTCSs), and such systems are used on almost every segment of the ISS. For many years over the course of its history, the ISS could experience both of these extremes simultaneously. In the early years of assembly, the ISS flew what was known as a solar inertial attitude (X-Perpendicular Out of Plane). The orientation of the vehicle was such that one side faced the sun throughout the daytime periods while the opposite side faced deep space. Therefore, the opposing sides of the ISS were exposed

to opposing thermal extremes throughout the daytime portion of each orbit (see Chapter 7). This attitude was necessary for dynamic stability and power generation but caused thermal stress on the vehicle. Portions of the ISS facing the Earth experienced a middle ground in this realm of extremes. The Earth radiates heat better than deep space while providing only a fraction of the heat of the sun, thus the portion of the ISS that faces Earth achieves a goldilocks middle-ground temperature of not too hot and not too cold. The thermal systems on the ISS were designed to protect it from these extreme thermal environments while keeping the astronauts in comfortable, shirt-sleeve surroundings.

Beyond the extremes of space itself, the ISS also requires a cooling process to maintain its many systems at operational temperatures. As on Earth, electronics and machines generate heat. In the gravity environment on Earth, system designers frequently use convective heat transfer in designing cooling systems, where warm air rises and moves away from the equipment to remove heat from machines. Thermal systems on the ISS rely on conduction, where heat is transferred from one substance to another through direct contact to provide cooling to heat-generating equipment, followed by radiation of that heat into space. (See sidebar: Convection—Gravity’s Cooling Mechanism.)

A particularly critical symbiosis exists among the Command and Data Handling, the Electrical Power System (EPS), and the TCS. The TCS is powered by the EPS, controlled by the software in Command and Data Handling and, in turn, cools both to keep them functioning. Every other

## Convection—Gravity’s Cooling Mechanism

Of the three primary mechanisms of heat transfer—conduction, convection, and radiation—convection is intuitively understood by most people based on their experiences on Earth. Hot air rises through convection, taking heat with it. For example, when placing a hand above a hot cup of coffee, a person can feel the rising warmth as the coffee cools. Convective heat transfer occurs when a fluid (air would be a fluid in this instance) is heated and becomes less dense. In a gravity environment, a warmer, less-dense fluid rises through the cooler fluid above it because the less-dense fluid is “lighter” than the colder, denser fluid. This free convection is responsible for the weather patterns on Earth, the flight of hot air balloons, and the usefulness of old-fashioned radiators. Without gravity, however, air will get hot and expand but will stay exactly where it is. This occurs because things are not “light” or “heavy” when there is no gravity. Without gravity, hot air will not rise. On Earth, if a computer is generating a lot of heat, it can be placed on a table, uncovered, and free convection will allow the heat to float up and away, thus keeping the computer from overheating. Inside the ISS, that same computer left floating in the middle of a module would simply heat the air around it, creating a bubble of heat surrounding the computer. On the ISS, a little more effort is required to keep that computer from baking itself. A fan can be used to blow the hot air away from the computer (which is known as forced convection), but the heat is simply being moved around to some other pocket of air. The heat will need to be removed altogether or all the air in the ISS will eventually get too hot. Computers outside the ISS pose yet another challenge since, beyond gravity, the other important part of convection is the air that carries the heat away. Computers outside the ISS are not surrounded by air. They are in the vacuum of space; therefore, a fan cannot help with cooling. Convection is not possible without some type of gas such as air or a liquid. Conduction is the process in which heat is transferred from something that is warm to something that is cool through direct contact. The ISS systems use conduction to carry unwanted heat from objects such as computers into fluid systems, which then carry the heat away from the heat-generating equipment and send that warm fluid flow through radiators, using radiation to release that heat into space.

system on the ISS is equally reliant on these three core systems in one way or another, creating an interconnected web of dependencies that have to be carefully managed in both normal operations and failure scenarios.

The TCSs on the ISS are comprised of a number of subsystems, all

working together to maintain the various structures and components of the space station at the temperatures required for operation and survival. Most of those systems arrived in orbit as part of modules or structures installed during ISS assembly missions of the Space Shuttle (see Introduction). One by one, each

subsystem was integrated into the whole as the station itself was built. As such, the story of the TCS on the ISS parallels the story of the ISS assembly. This chapter offers a review of each different subsystem as summarized here:

- PTCSs
  - Heaters
  - Insulation
  - Coatings
- ATCSs
  - General
    - Pumps
    - Heat exchangers
    - Valves
    - Accumulators and pressure systems
  - External
  - Internal

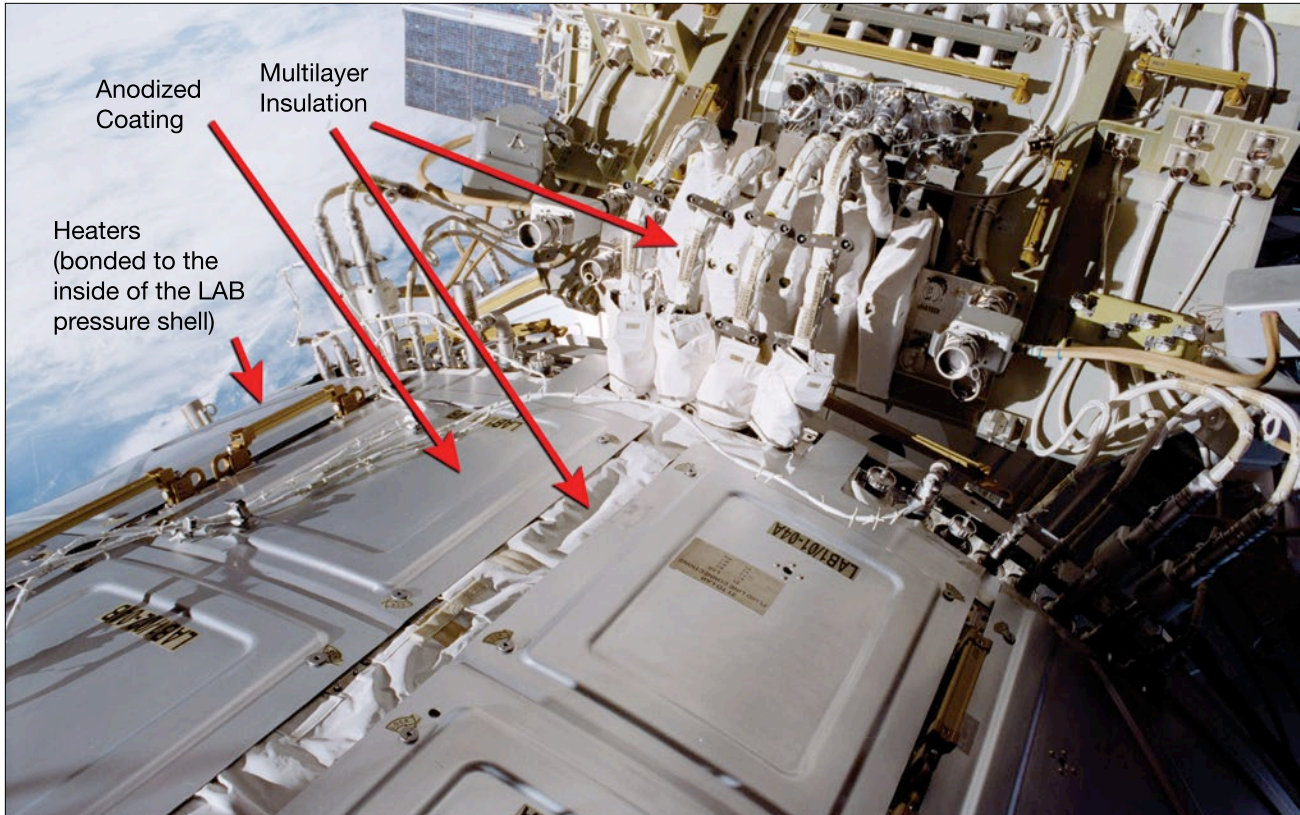
The PTCSs arrived with the first and last pieces of the ISS, and every segment along the way, and are discussed first. The ATCSs, both the ammonia-based fluid systems and the water-based fluid systems, are discussed next, initially summarizing the generic features of all such systems. Ammonia-based systems are used on the exterior of the ISS to move heat to radiators and release it into space. These ammonia-based systems are called External TCSs (ETCSs) and are used in a number of distinct applications even though they are of similar design. Water-based systems are used on the interior of the ISS to collect all of the heat generated by activity on the ISS from computers, experiments, and crew members, and to carry it to the ETCSs to be radiated overboard. The water-based systems are known as Internal TCSs (ITCSs) and can be found in each module on the US Segment, always in similar yet unique configurations.

## Passive Thermal Control Systems

A portion of the PTCS was the first ISS thermal subsystem that was launched into orbit. In this context, passive means thermal systems that do not use pumps and cooling fluids. The most basic form of a passive thermal system is insulation, which provides the same function as putting on a coat. Multilayer insulation consists of layers of thin aluminum and white cloth, 3.2 to 6.4 mm (0.125 to 0.25 in.) thick, that help trap heat. Another type of passive system is paint. To protect against the intense sunlight, areas may be painted white to reflect as much heating radiation as possible, or painted black to absorb heat to provide warmth. Heat pipes are used in several places on the outside of the ISS, usually to provide passive cooling of electronics mounted on the outside of the space station. A heat pipe is a hollow tube with ammonia inside. Several tubes will be aligned together such that one end of the pipes is in contact with the warm electronics, and the other end of the pipes is mounted a short distance away from the heat source. When the heat from the electronics is transferred to the ammonia in the tubes, the ammonia turns to vapor. When the ammonia vapor comes in contact with the cool end of the pipes, it releases the transferred heat and condenses back into a liquid, flowing back along the pipe to the warm end again to repeat the process. Heat pipes provide a simple and effective way to move heat away from electronics without the need for mechanisms that may require maintenance over time.

The final passive thermal system uses small heaters to keep hardware warm. When the Node 1 and Pressurized Mating Adapter 1 modules launched in the payload bay of the Space Shuttle Endeavour on December 4, 1998, they took with them the first sets of heaters installed on the inside of the shell on most ISS pressurized modules (see Chapter 3). These heaters were designed to protect the inside of pressurized structures from condensation. Condensation is possible on the inside due to the respiration of the astronauts. During pre-launch processing, each module of the ISS was pressurized with clean, dry air. On orbit, each module was exposed to slightly more humid air once it was attached to the station. In the same way water collects on the cold outer surface of a glass of ice water on a humid day on Earth, the water vapor in the air on the ISS is liable to condense on any especially cold surface. The dew point on the ISS (i.e., the temperature at which the water vapor in air will condense into liquid water) is usually kept in the 6°C to 8°C (42°F to 46°F) range. The outer walls of the space station, being the coldest surfaces in the pressurized sections of the ISS, are prone to drop below those dew point temperatures; therefore, heater patches consisting of nickel chrome wire embedded in patches of silicon rubber are spaced around the pressure shell of most modules on the US Segment to ensure surface temperatures are warm enough to avoid water pooling. Several types of passive thermal systems are shown in Figure 1.

Condensation on the ISS needs to be prevented for a couple of good reasons, beginning with safety concerns. Water allowed to collect as condensation on the walls of the



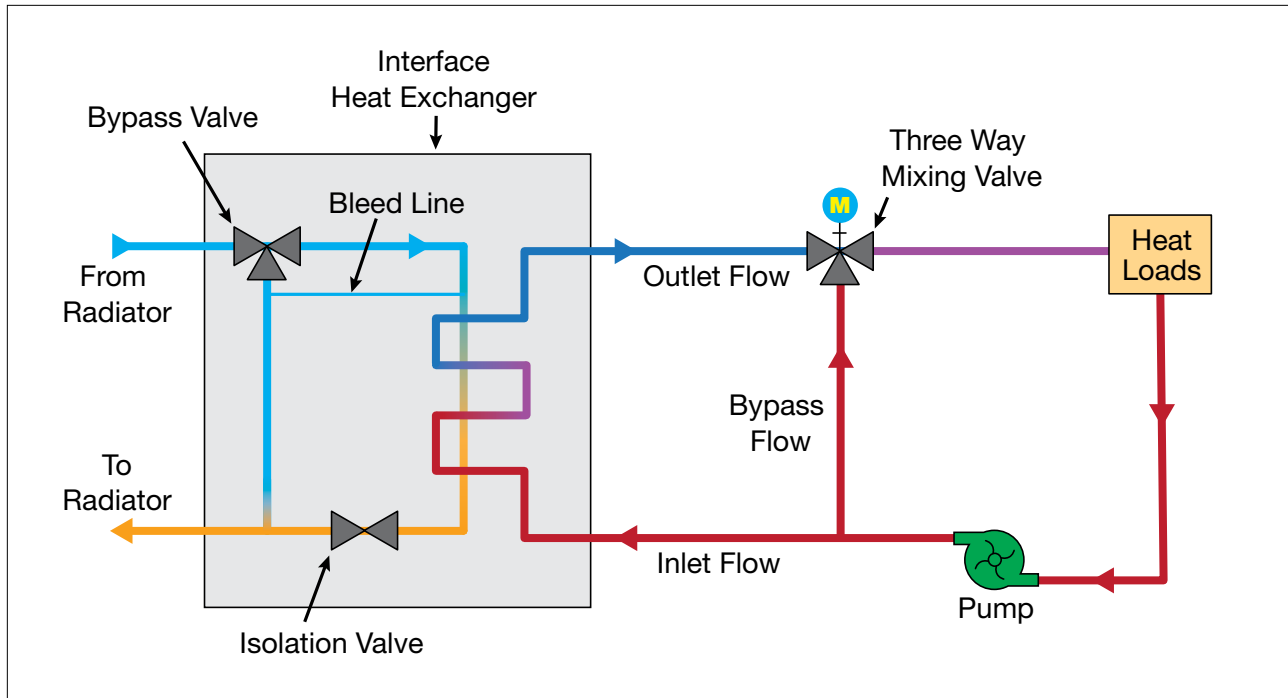
**Figure 1.** Various examples of PTCS are seen in this photograph of the Z1 truss connection to the Laboratory Module. The silver-like anodized coating of the modules helps reflect sunlight. Heaters (not visible) are bonded to the interior side of the pressure shell to keep it from getting too cold. Fluid connectors are wrapped in multilayer insulation to keep the temperature of the fluids within operational ranges.

space station could become free-floating water, which could cause irreparable damage if it came into contact with station electronics. Additionally, condensation can cause corrosion of metal structures in the form of rust. Corrosion can lead to small holes in the critical shell of the ISS or make the ISS more susceptible to structural fatigue under dynamic stresses that occur due to normal thermal cycling as the space station orbits the Earth or during propulsive events such as vehicle reboosts (see Chapters 7 and 8).

## Active Thermal Control Systems—General

Passive systems are effective for keeping particular areas at the right temperature; however, sometimes large quantities of heat need to be moved from one area to another or removed from the system altogether. Active systems are required when heat needs to be moved from its source to a different location where it can be expelled. The ISS has three types of active thermal systems: one internal and two external. A third external was available temporarily. This section describes the common characteristics of these active systems.

Every ATCS on the ISS is a closed-loop system, with fluid lines connecting heat “loads” (i.e., the equipment that needs to be cooled) to heat rejection points. This is exactly the same way a building or automobile air conditioner works. In an air conditioner, air moves over a tube filled with cold liquid so the heat transfers to the coolant. The now-warm liquid passes through tubes on the outside of the unit so that the heat can be absorbed by the outside air. In the ITCS, the heat loads are individual pieces of equipment such as computers, air conditioners, water processors, and experiments. Fluid lines pass close by these loads to



**Figure 2.** A schematic of an ATCS. Warm water (red) flow starts at the pump in the lower right of the diagram. Coolant passes into the IFHX where it will pass heat to the colder ammonia (blue then yellow) inside the heat exchanger. The now-cooled water (pink then blue) flows back to the loads to pick up more heat. The Three Way Mixing Valve (TWMV) is adjusted to regulate the temperature of the fluid going to the loads at the upper right of the diagram. Some warm fluid can be pulled directly into the TWMV, bypassing the heat exchanger, to make sure the fluid going to the loads is not too cold. On the left of the diagram, cold ammonia (light blue) comes into the heat exchanger from the radiators. Inside the heat exchanger, the ammonia picks up heat from the water such that it leaves the IFHX warmer (yellow) and returns to the external pump (not shown), which will push it back to the radiators again. A bypass valve will divert the flow of ammonia away from the heat exchanger when it is not being used. An isolation valve, in conjunction with the bypass valve, can be used to isolate the heat exchanger and prevent colder-than-normal ammonia from reaching the center of the heat exchanger. This might be needed during repair work, for example. The heat exchanger cannot be completely isolated from the ammonia side of the system due to the presence of what is known as a bleed line. When a heat exchanger is isolated, there is a risk that the ammonia remaining in the heat exchanger could get hot and increase in pressure. The bleed line provides a pressure relief capability, allowing ammonia to safely escape the heat exchanger if it heats up. The “M” in a circle over some valves indicates a manual override, which means an astronaut could adjust that valve if, for some reason, the computer control was not working properly. See also Figure 2 in Chapter 20.

absorb some of the heat generated by the load, thereby warming the fluid. The point in an active thermal system where heat leaves the loop is referred to as the heat rejection point. The heat rejection point for the ITCS loops is an Interface Heat Exchanger (IFHX), which provides a connection point between the ITCS inside the ISS and the ETCS outside of the ISS (Figure 2). In a heat exchanger, a warm fluid passes by a colder fluid, thus allowing heat to be rejected from the hot side to the cold side. In the ETCS, the heat exchanger

provides the heat load, and the heat rejection points for the ETCS are radiators that radiate heat into space. Pump hardware in each type of loop circulates the coolant (either water or ammonia) through the cooling loop. Each cooling loop has a number of sensors, valves, and controllers to maintain desired loop temperatures and monitor for problems in loop operation. The cooling loops inside and outside the ISS use many common components, but the details of how those components are designed or configured differs based

on the specific needs of the cooling application, as discussed in the following sections.

Each fluid loop on the ISS uses a Three Way Mixing Valve (TWMV) to control loop temperature, as shown in Figure 2. These three-way valves are similar to a single-handle faucet control at a kitchen sink. As with kitchen faucets, these three-way valves have two sources of liquid that are blended together into one outlet. One source of coolant flow at TWMV comes from the heat rejection

point in the loop and provides the coldest fluid in the loop. This source is comparable to the water coming from the water main into the kitchen. The second source comes from a line that bypassed the heat rejection point and is still warm. This source is similar to the water coming from the water heater, but instead of being intentionally warmed, it is warm from the heat loads on the ISS. The two sources are known as the return line and the bypass line, respectively, and the valve position determines how much of the warm bypass line coolant is added to the cold return line coolant in the outlet line. In the three external cooling loops, these valves are called Flow Control Valves (FCVs). Three-way valves are also used to provide control of loop pressure at some points in the ITCS, as will be discussed later in the ITCS section of this chapter.

The active systems use one or more accumulators to manage loop pressures. Accumulators serve three purposes in ISS fluid loops: they allow for thermal contraction and

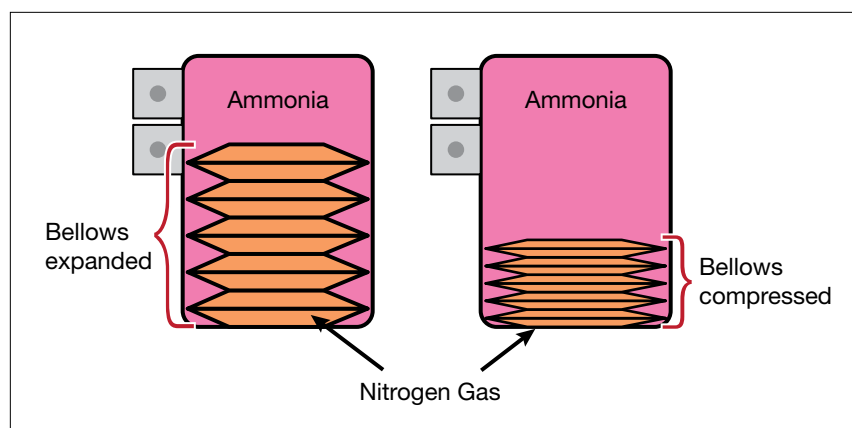
expansion of the cooling fluid, ensure sufficient pressure at the inlet to each fluid system pump, and provide a small amount of makeup fluid in the event of a fluid leak. An accumulator is a small tank with a compressible metal bellows inside (Figure 3). A bellows is an accordion-like container that is able to expand and contract freely. On the ISS, the tank usually contains the cooling fluid and the bellows contains nitrogen at a desired pressure. Since the bellows is free to expand and contract, the pressure of the coolant will match the pressure of the nitrogen; therefore, the nitrogen pressure is used to control and maintain the pressure of an entire cooling loop, through the accumulator.

After detailed engineering analysis, NASA chose ammonia as the coolant for the ATCSs on the exterior of the space station for several reasons: ammonia has a lower density than many other commercially available coolants and can therefore be launched in great quantity at dramatically reduced launch costs; it has a low viscosity so it requires

little power for pumps to circulate the ammonia through cooling loops; and ammonia remains liquid down to  $-78^{\circ}\text{C}$  ( $-108^{\circ}\text{F}$ ), which is important in the extreme cold of the ISS external environment. On the downside, ammonia is toxic to humans; therefore, the possibility of this dangerous chemical leaking into the pressurized cabin is one of the three major emergency responses discussed in Chapter 19.

## Active Thermal Control—External Thermal Cooling Systems

The ETCS expanded significantly throughout construction of the space station, though the fundamental design of the system remained the same. These systems have been critical to human presence on the ISS. Without the ability to reject heat from the interior of the ISS overboard, the many systems inside the station cannot operate for long without the air becoming unbearably hot. The challenge during assembly of the ISS was that the large, permanent ETCS loops would not arrive until the latter half of the construction sequence. The ammonia loops arrived already integrated into the truss segments that make up the backbone of the ISS, providing structure and infrastructure for power to flow from the outboard solar arrays into the central core of the station. Many of the habitable modules of the ISS arrived years before the truss was completed, but they could not be fully activated until the permanent thermal and power systems arrived with the trusses. The assembly sequence was altered to provide one truss segment, P6, early in the sequence, with a pair of solar



**Figure 3.** The accumulator for the Pump Flow Control Subassembly is illustrated, but the other TCS accumulators work on the same principles. Fluid (in this case, ammonia) is in the tank surrounding the orange bellows, which can expand and contract. Nitrogen gas within the bellows provides pressure on the bellows, which in turn applies pressure to the ammonia to help ensure it can move around the system properly.

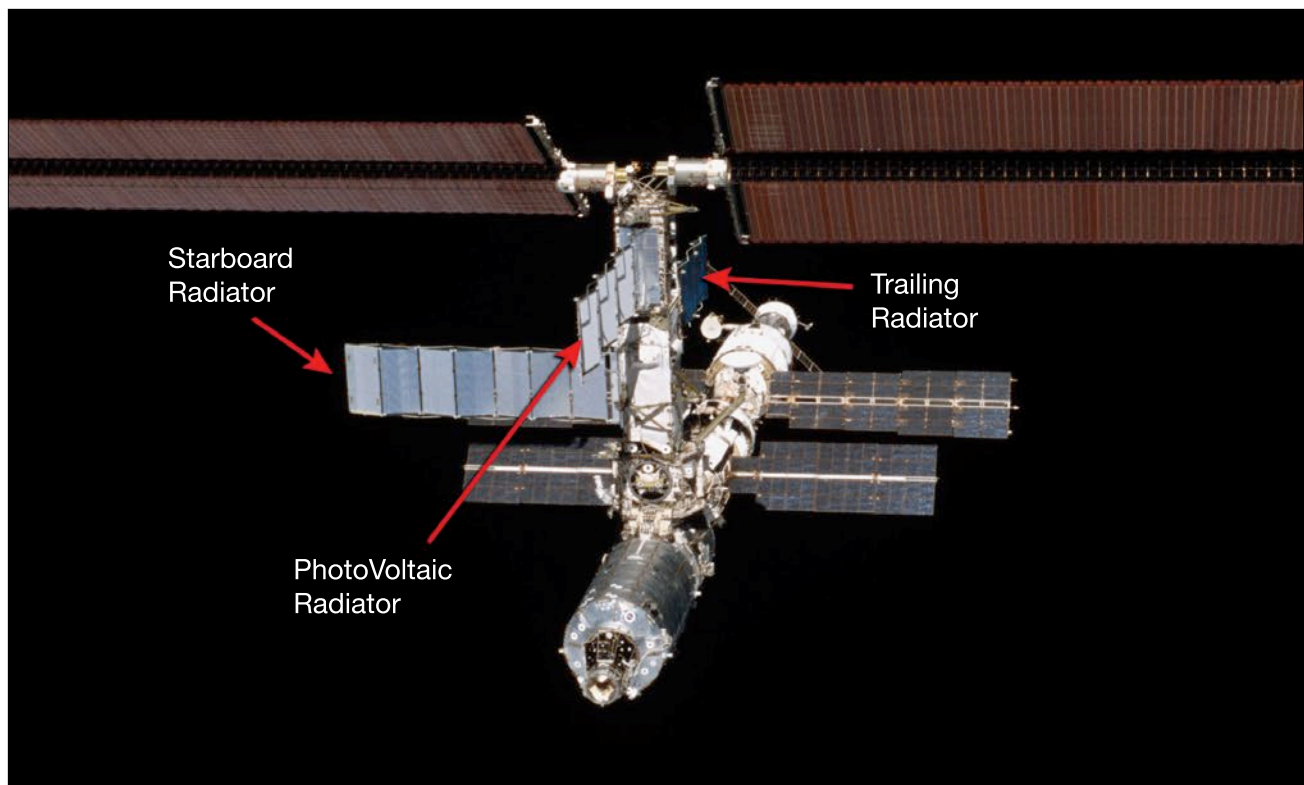
arrays and two pairs of ammonia loops, thus providing power and cooling to the evolving space station much earlier than originally designed. This was done to expedite human presence on the ISS and begin the ISS research program.

The P6 truss segment was outfitted with two cooling loops to provide cooling to the habitable modules, specifically to support the ITCS and allow for early activation of interior systems. The augmented P6 truss was installed on the zenith face of the ISS during STS-97/ISS-4A in late 2000, during the third ISS assembly flight of the Space Shuttle. The additional cooling loops were known as the Early External TCS (EETCS). Along

with the 2B and 4B solar arrays and associated power channels, the EETCS allowed for a complete activation of the Laboratory Module (LAB) systems once the LAB was installed on STS-98/ISS-5A in 2001. See Figure 4. The P6 truss stayed in this location while the remainder of the ISS was built around it. The early external cooling system was deactivated with the arrival of the remaining truss segments in 2006 and 2007 and the activation of the permanent ETCS. Ultimately, the P6 truss was relocated to its design location as an outboard truss segment, though not without incident (see Chapter 18). Power channels 2B and 4B and their associated cooling loops are again active; however,

the EETCS is permanently retired, and provides spare parts for eight of the cooling loops on the ISS. The permanent system shares many common features with the EETCS, which would later play yet another role, as detailed in this chapter.

The final configuration of the ISS includes two types of ETCSs. Loops A and B form a redundant pair of loops that provide cooling for the core of the ISS. Eight smaller ammonia loops, known as the PhotoVoltaic TCS (PVTCS), each service one channel of the electrical system, and are named for the power channel they support (e.g., PVTCS 1B for the 1B power channel). (See also Chapter 9.)



**Figure 4.** Picture of the early space station after STS-98/ISS-5A. The P6 module with its set of arrays and the EETCS was temporarily attached to the Z1 truss. Two radiators labeled the trailing EETCS (since it pointed aft) and starboard (since it pointed starboard) provided cooling for the entire US On-orbit Segment. The PhotoVoltaic system on P6 has its own TCS called the PhotoVoltaic TCS with a forward-pointing radiator called simply the “PVR” (PhotoVoltaic Radiator), which provides cooling to electrical power generation and storage systems on the element.



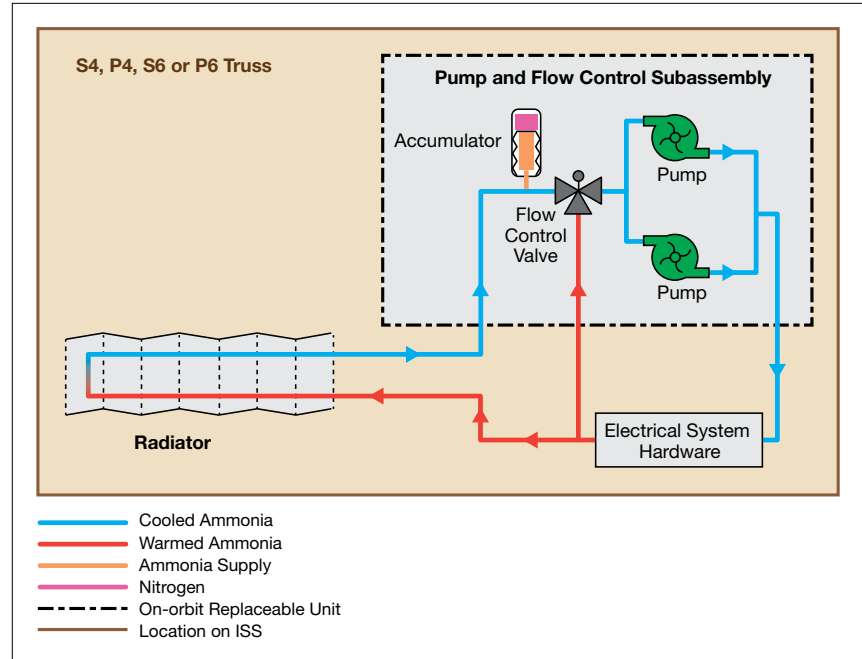
## External Thermal Control Systems—Temperature Control

As mentioned earlier in the chapter, FCVs are the three-way valves that provide temperature control in external thermal loops on the ISS. In the ETCS, the FCV must maintain loop temperature within a fairly tight tolerance (around 4°C [39°F]) to provide ammonia sufficiently cold to draw heat from the heat exchanger, but also sufficiently warm to avoid freezing the water on the ITCS side of the heat exchanger. In comparison, the PVTCS FCV simply moves all the way to return flow (i.e., full cool, also known as “open”) if the ammonia from the EPS batteries is too warm, and then moves all the way to bypass flow (i.e., full hot, also known as “closed”) when ammonia from the EPS batteries is too cool. Thus, the FCV in the ETCS has much finer control algorithms than the one in the PVTCS.

## External Thermal Control Systems—Pumps and Accumulators

In a PVTCS, the pump is within the Pump and Flow Control Subassembly (PFCS), which provides ammonia circulation and control of the loop temperature and pressure. The PFCS contains the following: two pumps; the FCV to control loop temperature; a fluid accumulator to control loop pressure; a suite of sensors to monitor temperature, pressure, flow, and ammonia quantity; and an electronics unit to control all mechanisms on the loop. See Figure 5.

The accumulators serve two purposes in the PVTCS. Since ammonia is incompressible, rapid heating causes the fluid to expand quickly. If there is no method to accommodate that

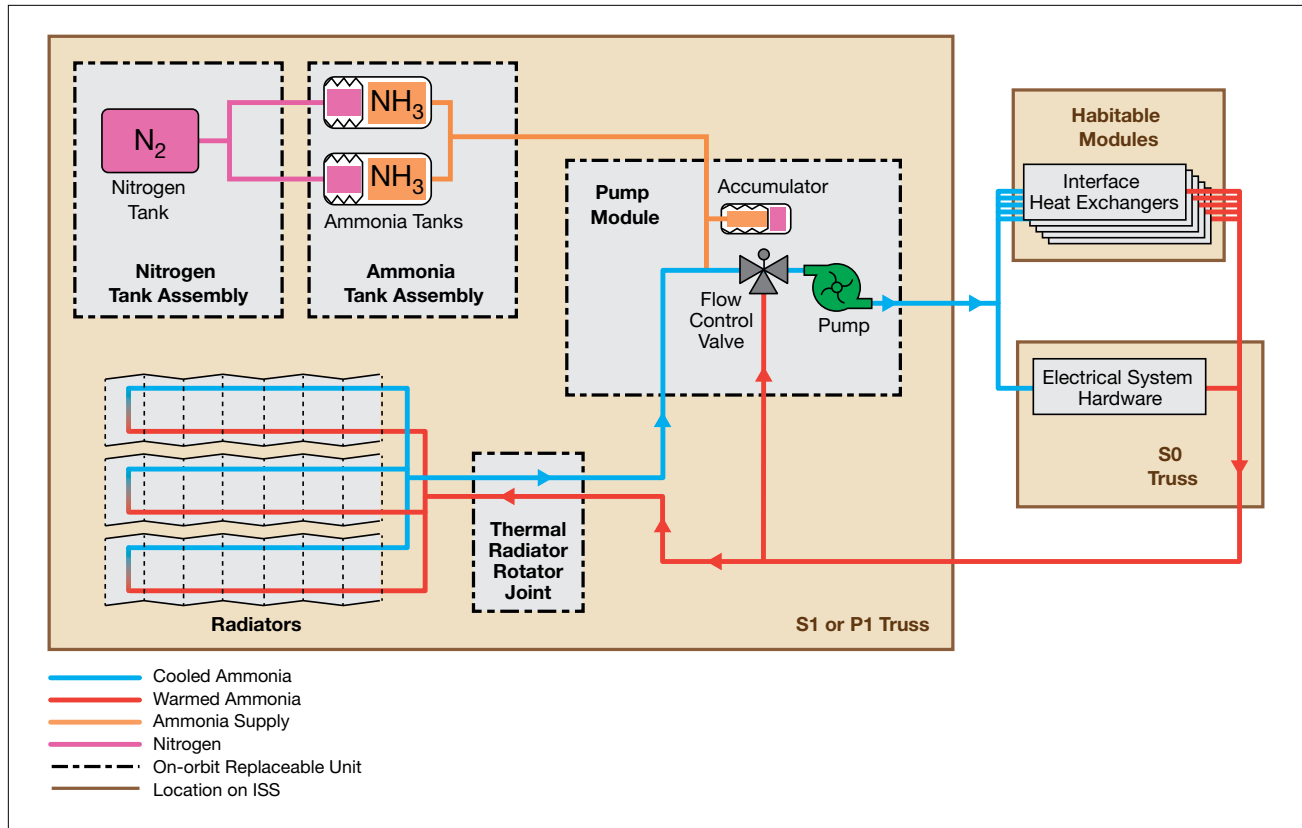


**Figure 5.** A simplified schematic of the PhotoVoltaic Thermal Control System. Redundant pumps (green) push cool ammonia (blue) to the electrical power generation and storage systems. The electrical systems are cooled by the ammonia absorbing the heat (red). The warm ammonia passes through a radiator where the heat is transmitted to space. The cooled ammonia (blue) returns to the Pump and Flow Control Subassembly to repeat the cycle. An accumulator maintains the pressure on the fluid line when the liquid expands or contracts as temperatures vary during an orbit around the Earth and throughout the year. A flow control valve allows mixing of warm and cool fluid to adjust the temperature of the loop.

expansion, line pressures can quickly exceed the capacity of the fluid lines, which leads to burst lines. This is of particular concern in the PVTCSs, which were filled with ammonia coolant when launched, and were exposed to extreme thermal environments once they reached orbit but before they were activated. The first purpose is to provide room for ammonia to expand when it gets hot. The second purpose is to provide ammonia to compensate for a small amount of leakage from the system over time.

The PFCS pumps in the PVTCS and the EETCS are run by a three-phase 120 volts (direct current) brushless pump motor and were set to operate at 13,580 revolutions

per minute (rpm) to provide an average ammonia flow rate of 862 kg/hr (1900 lb/hr). The PVTCS are comparatively small and simple loops, with fairly short lines and no parallel flow paths, thus requiring much less pumping power than would ultimately be needed for the much larger and more complex ETCS. By comparison, the ETCS pump provides an average flow rate of between 3175 and 4309 kg/hr (7000 and 9500 lb/hr). The ETCS pump capacity is discussed later in this chapter. Each PVTCS and EETCS loop contains two identical pumps in case one fails. However, there is only one FCV per loop, since valves are generally more reliable than pumps.



**Figure 6.** A simplified schematic showing the major components and flow paths of the External Thermal Control System (ETCS). The ETCS is very similar to the PhotoVoltaic Thermal Control System shown in Figure 5. Starting in the pump module, a pump (green) pushes cool ammonia (blue) to either the electrical distribution systems on the exterior of the ISS or heat exchangers on the habitable modules where heat is picked up from the Internal Thermal Control System (discussed below and shown in Figure 10). The warm ammonia (red) passes through a rotating mechanism called the Thermal Radiator Rotator Joint to radiators where the heat is transmitted to space. The cooled ammonia (blue) returns to the pump module to repeat the cycle. A flow control valve in the pump module allows mixing of warm and cool fluid to adjust the temperature of the loop. An Ammonia Tank Assembly (ATA) performs the role of an accumulator, maintaining the pressure on the fluid line as the liquid expands or contracts through the orbit or year. Unlike the PVTCS, the ETCS has a replenishable nitrogen tank to maintain pressure at the ATA. A fixed-pressure accumulator in the pump module is too small to maintain loop pressures year round, but can maintain stable pressure for short periods if the ATA/NTA combination is unavailable.

The ETCS pump is located within an assembly called the pump module, which consists of a Pump and Control Valve Package, an accumulator, several valves, and a suite of sensors to monitor temperature, pressure, flow rate, and ammonia quantity (Figure 6). The pump and control valve package contains a pump, an FCV, sensors to monitor temperature and flow rate, and a firmware controller to control the pump and FCV. Each ETCS loop has one pump module, located in

the S1 truss segment for Loop A and the P1 truss segment for Loop B. In August 2010 and December 2013, the pump module on Loop A failed, cutting off half the cooling and leaving the station one failure away (on Loop B) from losing all cooling. Without cooling, the equipment would overheat and ultimately fail. Since most of the critical systems have two identical instances to provide for redundancy, the failure of one loop meant half of these systems had to be

shut down. If the other loop failed, or if any of the redundant equipment that it cooled broke, the station would no longer be viable for supporting the crew. The crew conducted three emergency spacewalks later that month to restore functionality (See Chapter 20).

As with the PVTCS, the accumulator in the pump module accommodates thermal expansion and contraction of ammonia within the pump

module when the ETCS is dormant. Pressure control of the ETCS loops during operation is provided by a combination of a Nitrogen Tank Assembly (NTA) and an Ammonia Tank Assembly (ATA), which together act as a large ammonia accumulator for each ETCS Loop.

The ETCS contains 118 L (31 gal.) in each of two loops. As mentioned above, any segment of fluid line filled with ammonia must have access to a pressure relief mechanism, usually an accumulator or a mechanical pressure relief valve, to ensure that rapid ammonia temperature increases do not cause overpressurization, which could burst lines. Because the ETCS loops were launched to orbit in many sections across several flight elements, each section was filled with nitrogen rather than ammonia. Using inert nitrogen, which does not respond to temperature extremes with the same pressure changes to which ammonia is susceptible, prevented the need for additional accumulators throughout the system. Once the entire system had been assembled on the ISS in 2006, the nitrogen was vented and the system was filled with ammonia just prior to activation. This strategy allowed all of the ammonia to be contained in a set of ammonia tanks for launch and installation; therefore, the cost of overpressure protection was limited to the design of those ammonia tanks, which were then incorporated into the ETCS as part of the ATA.

The ATA is a box that measures approximately 175 x 102 x 137 cm (69 x 40 x 54 in.). The box consists of the following: two ammonia tanks; an isolation valve for each tank; pressure, temperature, and quantity sensors for each tank; the plumbing

needed to connect the ATA to the rest of the ETCS; and a vent valve on a line connected to both tanks. Each ATA holds 397 L (105 gal.) of ammonia. Each of the ATA ammonia tanks includes a bellows filled with pressurized nitrogen, such that each tank is able to act as an accumulator, accommodating thermal expansion and contraction of the ammonia, pressurizing the loop for optimal pump performance, and providing ammonia to make up for leakage over time. The nitrogen side of the ATA is connected to the NTA, a box that measures approximately 152 x 91 x 76 cm (60 x 36 x 30 in.) and consists of a nitrogen tank, pressure and temperature sensors, a Gas Pressure Regulating Valve (GPRV), and two isolation valves. The plumbing in the NTA connects the nitrogen tank to the GPRV. The plumbing then splits into two lines (one connecting to each tank in the ATA), each with an isolation valve that can cut off the NTA from the associated ATA tank.

The PVTCS accumulators have a fixed charge of nitrogen that cannot be changed or replenished, whereas the nitrogen pressure in the ATA can be adjusted using the GPRV in the NTA. The GPRV is a combination of four separate valves that can be used to increase or decrease the pressure of the nitrogen that is fed to the ATA tanks. Therefore, the GPRV is used to add or remove nitrogen to increase or decrease, respectively, the pressure in the ammonia lines as needed.

Whereas the EETCS was a temporary and fairly simple system with pumps that operated at a fixed speed, the ETCS pump operates at variable speeds so that its capability could be adjusted as additional lines were

added to the system over time. When the ETCS was first activated, it connected only to the heat exchangers on the LAB. Over time, as additional modules were added to the ISS, additional ETCS lines were added to provide access to the heat exchangers on those modules, which required additional capability from the pump. The ETCS pumps can operate between 11,250 and 18,000 rpm, as required to provide a system flow rate of 3,719 to 4,037 kg/hr (8200 to 8900 lb/hr).

### ***External Thermal Control Systems—Heat Exchangers***

As seen in Figure 2, an IFHX is an assembly that consists of a heat exchanger core, two valves, three heaters with associated temperature sensors (not shown), and four fluid connectors to connect the heat exchanger to water inlet and outlet lines and ammonia inlet and outlet lines. The heat exchanger core uses a counterflow configuration, with ammonia and water that flow in opposite directions in adjacent layers. Each layer uses a ruffled fin material (i.e., stainless steel for the ammonia layers and nickel for the water layers) separated by a stainless steel parting sheet to keep the fluids separated. The ruffled fins help hold the parting sheets together and provide additional surface area to increase heat transfer. There are two heat exchanger core configurations: one rated to transfer up to 14 kW of heat; the other rated for up to 12 kW of heat transfer. Of the 10 heat exchangers on the ISS, eight are the 14 kW design and two are the 12 kW design. Chapter 4 discusses some of the challenges of working with the heat exchanger units on the Node 3 module.

The three-way valve in the heat exchanger assembly provides the ability to divert ammonia flow such that it bypasses the heat exchanger core. This valve is called a bypass valve (Figure 2). When the ETCS loop is off, this valve is adjusted to allow the ammonia flow to bypass the heat exchanger so that when the loop starts up, the super-cold ammonia will not be able to remove too much heat from the internal system. Although it sounds desirable to reject as much heat as possible, there is a point where things can get too cold. Because water expands as it freezes, the heat exchanger is not allowed to reach the freezing point of water. Otherwise, the frozen water will expand such that it ruptures the stainless steel parting sheet and then contracts as it thaws, leaving a hole for ammonia to leak through and into the cabin. An Isolation Valve—a two-way (i.e., two-position) valve that can be closed to isolate the heat exchanger core from ammonia flow—helps prevent the water from freezing in the IFHX. The ETCS ammonia is kept at a temperature of about 3.3°C (~37.9°F). If the temperature drops below that level, software in the system will automatically stop ammonia flow and configure these valves to bypass and isolate the ammonia side of the IFHX. When a heat exchanger is bypassed and isolated, it is hydraulically locked such that any sudden temperature increases within the ammonia will put the heat exchanger at risk of overpressurization. As another check to prevent overpressurization, the heat exchanger has a small ammonia fluid line, called a bleed line, which connects the ammonia inlet close to the heat exchanger core with the ammonia outlet outside the isolation valve. Some ammonia can escape

through this line if pressure gets too high inside the isolated IFHX core.

Heaters attached to the heat exchanger core and the water inlet and outlet lines are designed to prevent freezing of the water side of the heat exchanger. Additional safety checks in the ETCS software help detect issues and prevent the heat exchanger from freezing. The first response was detailed above: if the ammonia temperature drops to about 1.1°C (34°F), the ETCS pump will automatically shut down and the heat exchanger will be bypassed and isolated to prevent cold ammonia from entering the heat exchanger. The second and third checks monitor the quantity of fluid in the internal system pump accumulator. If the quantity of water measured in the accumulator begins to rise, the only source of fluid would be ammonia leaking into the water. Therefore, if the accumulator quantities in the ITCS go above a threshold, the pumps will be shut down to help prevent pushing ammonia into the cabin. As discussed in Chapter 19, the case of toxic ammonia leaking into the crew cabin is one of the three critical emergency events for which the crew and ground regularly train (see also Chapter 10).

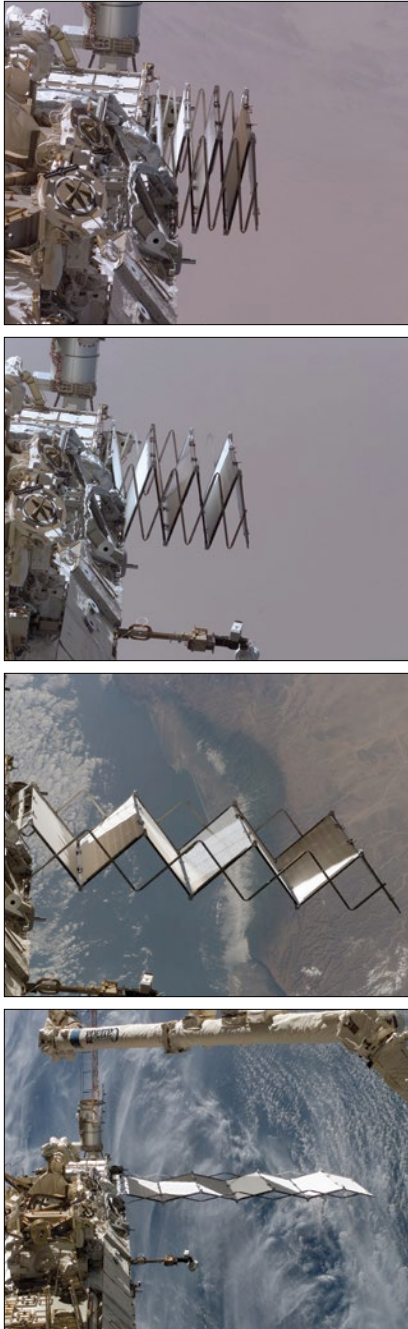
### ***External Thermal Control Systems—Loads and Radiators***

The final component included in all the external thermal systems is the heat rejection point: the radiators. Although there are two types of radiators, they work the same way by providing radiative heat transfer from ammonia loops on the ISS. One type is known as a PhotoVoltaic Radiator (PVR), which is installed in the eight PVTCSs. The second type is known as the Heat Rejection Subsystem (HRS) or, more commonly, the ETCS

radiators. Both types of radiators consist of a base panel connected to a series of radiator panels that are hinged together, accordion-style, such that they can be deployed (i.e., straightened out, end to end) or retracted (folded back together, face to face) (Figure 7). Each radiator was fully retracted at launch and has an automated deploy/retract capability with a manual override that can be controlled by a spacewalking astronaut.

The P6 truss segment houses a total of three radiators. One radiator, known simply as the 2B/4B PVR, faced forward to be shared between the two PVTCS loops. The remaining two radiators were shared between the two EETCS loops. One radiator faced aft and therefore is still known as the Trailing Thermal Control Radiator (TTCR). The other radiator faced starboard in the original P6 location, and is known as the Starboard Thermal Control Radiator. Note: Now that the outboard truss segments rotate 360° to support solar array pointing, neither name is accurate. See also Figure 4.

The PVR radiator type is always shared between two independent loops and has seven radiator panels. The seven panels together can reject from 9.5 to 14 kW of heat, depending on the thermal environment. This is equivalent to the capacity of the air conditioner in an average house in the southern United States. The inside of each radiator panel is a honeycomb made from aluminum sheeting, with that honeycomb sandwiched between two 0.254 mm (0.010 in.) sheets of aluminum that are then coated with either silver or white coating to ensure optimal reflectivity. Each panel has 24 stainless steel tubes that measure 0.17 cm (0.067 in.)—12 tubes for



**Figure 7.** Deployment of the PhotoVoltaic Radiator on the P3 truss during STS-115/ISS-12A in September 2006. The sequence from top to bottom shows the radiator unfolding from the compact launch configuration to its fully extended length, approximately 12.53 m (~493.4 in.). Each of the seven radiator panels is approximately 3.12 x 1.79 x 0.02 m (~124 x 70.6 x 0.69 in.), or about the size of two queen-sized mattresses placed next to one another.

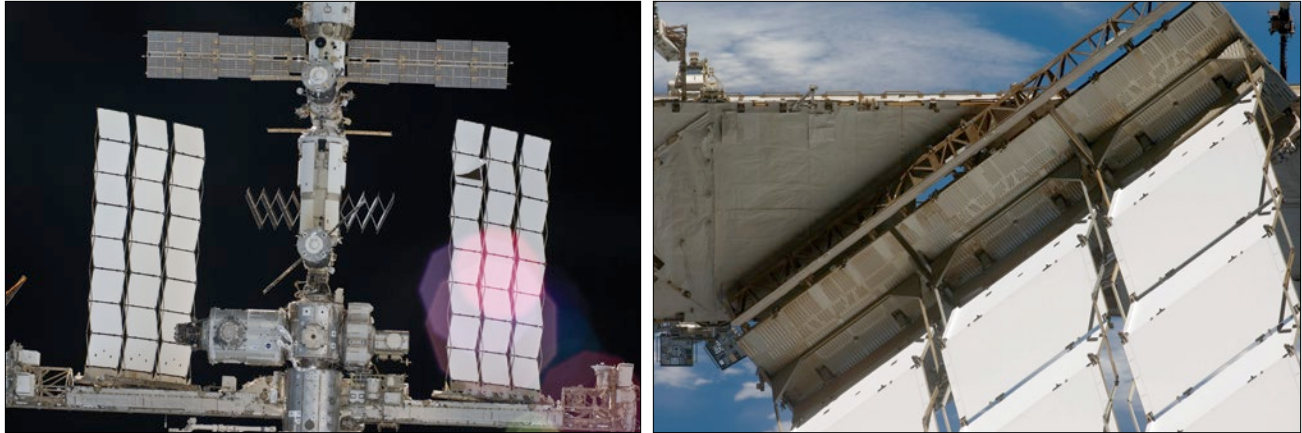
each of the two loops sharing the radiator—to carry ammonia across the radiator panel. Ammonia flows down one side of a PVR/TCR radiator through the tubes running through the panels and then back up tubes on the opposite end of the panels. The tubes along the ends of the panels are connected from one panel to the next with flexible hoses where the panels hinge together so that ammonia can get all the way to the last panel. Heat from the warm ammonia radiates into the coldness of space as the fluid moves along the large radiator panels.

In the EETCS, ammonia flowed from the PFCS through the P6 lines to Z1, through the Z1 lines to the aft end of the LAB where it joined the fluid lines on the LAB Aft Endcone, and through the heat exchanger to collect heat. The warmed ammonia then flowed back through Z1 and P6, this time all the way up to the radiators. The flow from each EETCS loop split, some flowing through the TTCR and some flowing through the Starboard Thermal Control Radiator. Some of the flow bypassed both of the radiators to provide warm ammonia to the FCV in the PFCS, which performed temperature regulation. Most flow from the heat exchanger flowed through the radiators to provide cold ammonia to the FCV, which then merged the warm and cold ammonia to achieve the desired temperature for ammonia to return to the pump, where it started the journey again.

The PVTCS follows the same basic path, except that all heat loads are contained on one truss so the loops never leave that truss segment. Ammonia flows from the PFCS to the batteries and other control equipment

that require cooling, then both PVTCS loops flow through the single PVR to the PFCS. If the electrical equipment is cool enough to not require cooling at that moment, the FCV flow will bypass the radiators and go directly to the pump where it starts the loop again.

The ETCS radiators are functionally the same as the EETCS/PVTCS radiators, though far larger and somewhat more complex. Each Heat Rejection System radiator has eight panels, each measuring 3.4 x 2.7 m (131.25 x 107.00 in.), or a bit bigger than two king-size mattresses placed side by side. Together, the eight panels that make up one HRS radiator can reject up to 11.67 kW. The HRS radiator panels are built in much the same way as PVR types. Ammonia flows through the radiators the same way, though the HRS panels have only 22 stainless steel tubes to carry ammonia across the radiator with each tube—about double the size of those in the PVR radiators at 0.32 cm (0.13 in.) in diameter. Each HRS radiator is used by only one ETCS loop, but each has two independent flow paths, thus allowing some flexibility of cooling capability. The 22 tubes that run across each radiator panel are distributed between the two independent flow paths in an alternating pattern. Each ETCS loop has three HRS radiators installed side by side on a large rotating plate called a Radiator Beam Truss Structure, as shown in Figure 8. Three radiators provide a total of six radiator flow paths for a combined heat rejection capability of up to 35 kW for each ETCS loop. The radiator flow paths were filled with nitrogen for launch and installation, and the cooling capability has proven



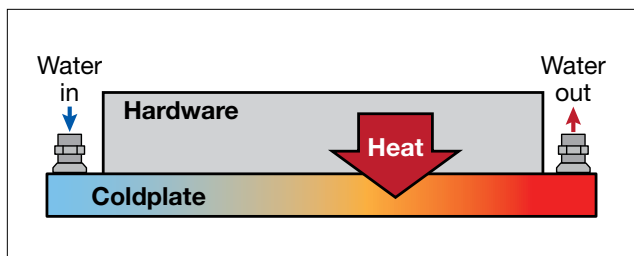
**Figure 8.** A major component of the ETCS as seen from the Space Shuttle. The left image shows the port and starboard radiator beams (three radiators per beam, with each radiator consisting of eight panels). On the right is a close-up of the Radiator Beam Truss Structure that is rotated by the Thermal Radiator Rotary Joint to maximize heat rejection.

greater than the need. Therefore, some of the flow paths still have their original nitrogen fill and have not yet been used.

Though the EETCS radiators on the P6 truss were fixed, each set of ETCS radiators can be rotated to improve heat rejection by positioning the radiator beam so that its three radiators are in an edge-to-sun position. This rotation is accomplished via the Thermal Radiator Rotary Joint (TRRJ) (Figure 8), which uses many of the same components as the Solar Array Rotary Joint (SARJ) described in Chapter 9. As with the SARJ, the TRRJ consists of a pair of drive/lock assemblies and a pair of rotary joint motor controllers (see Chapter 9). Unlike the SARJ, the TRRJ has a limited rotational capability because it is impractical to

use fluid connectors that have a full 360 degrees of rotation. Instead, the fluid hose rotary coupler provides fluid connections from one end of the TRRJ to the other, and the hoses within the fluid hose rotary coupler limit rotation to 210 total degrees of rotation, 105 degrees in each direction. The TRRJ interface is also much smaller than the SARJ interface. Whereas the SARJ rings are as large as the truss segment that houses it (i.e., large enough for a person to stand inside), the TRRJ is a fairly compact cylinder installed in the center of the S1 and P1 truss segments. Also, unlike the SARJ, the TRRJ generally does not need to rotate very much and can be left in the same position, changing only for specific attitude changes or certain solar beta angles (see Chapter 7).

The primary purpose of all three external systems is to cool the heat exchangers that provide heat transfer from pressurized modules. However, the ETCS also supports several EPS components that are located on the truss segments. These electrical components are mounted on an interface known as a coldplate, which both connects the component to the truss and provides an interface for ETCS cooling (Figure 9). Each coldplate is a broad plate with narrow-set fins extending from it. Those fins interleave with fins extending from the electrical component such that heat from the electrical component fins radiates to the coldplate fins. This finned plate is bonded to a stainless steel flow plate, which is sealed to allow ammonia flow through the unit to pick up heat transferred through the aluminum fins. Each ETCS loop provides cooling to five electrical components in addition to five heat exchangers. Though the heat load from the electrical components is a small fraction of the heat load from the heat exchanger, the electrical components are fully dependent on ETCS cooling to function at full capacity.



**Figure 9.** A schematic showing how a coldplate works. Cold liquid flows in from the left side and picks up heat generated by the attached hardware. The warmed liquid then flows out toward the radiators.

## Active Thermal Control— Internal Cooling Loops

The equipment in the various ISS pressurized modules is cooled by the ITCSs, which function similarly to the external systems. Each major module—LAB, Node 2, Node 3, Japanese Experiment Module, and Columbus Module—has a separate ITCS. Equipment in the airlock is cooled by the LAB ITCS. The internal cooling system in each of these modules performs the same function and has roughly the same design even though there are differences in each module due mainly to differing needs, but also because of slightly different design approaches among the contractors who provided the systems. This section will focus on the LAB ITCS as an illustration of the ISS ITCS, then touch on the differences among the systems in the different modules. Water is used in the loops inside the ISS; ammonia is used in the cooling loops external to the ISS. Since water provides high thermal capacity (i.e., it is able to absorb a great deal of heat) with low viscosity (i.e., flows easily without requiring powerful pumps) and is not harmful to humans, it was a straightforward choice for internal cooling systems that operate at moderate temperatures.

The LAB ITCS, shown in Figure 10, is a water loop system that can be configured as two independent loops or as one combined loop, thus providing redundancy and flexibility in operations. When configured as two separate loops, each loop has a pump assembly, a number of valves, and water lines passing through the LAB pressure shell to reach the IFHX where heat is passed from the ITCS to the external system. In each loop

## When the International Space Station Needed a Plumber

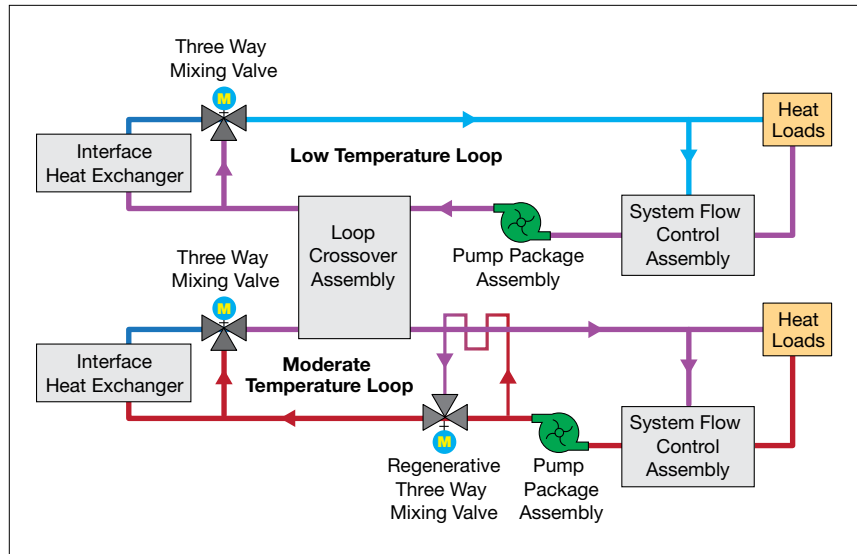
In 2004, the 2B PVTCS developed a small leak. The leak was slow enough that it was tolerated. However, in 2012, the rate of leakage greatly accelerated and it was possibly increasing exponentially fast. At that rate, the loop would exhaust its ammonia supply fairly quickly. Fortunately, a spare, dormant system—the EETCS—was available. The operations team quickly developed a contingency spacewalk to replumb the ammonia flow from 2B through the TCR of the EETCS. This was accomplished during an extravehicular activity (EVA) when the crew put in two fluid line hoses to connect the two systems. The TCR had been retracted after it had been decommissioned, so it also had to be redeployed manually by the spacewalking astronauts. Although this did not stop the leak, it did show that the leak was not due to a hole in any of the myriad little tubes inside the radiator panel, which would be extremely hard to repair, if at all. In May 2013, the rate had again increased when ISS Commander Chris Hadfield noticed ice flakes coming from the port truss while performing an EVA. At the new rate, the loop would potentially be unable to sustain cooling in 24 to 48 hours. Once again, the operations team quickly put together a spacewalk within 48 hours to replace the pump assembly, which ultimately fixed the leaking system. In November 2015, the jumpers were removed and the cooling system returned to its nominal configuration. In a follow-on EVA in August 2016, the TCR was retracted again and returned to a dormant storage configuration until it may be needed in the future.

configuration, warm water flows through the pump and is then sent to the heat exchangers for cooling. The cooled water flow then splits across many parallel paths to reach the equipment in racks throughout the module, is warmed by that equipment using coldplates, and returns to the pump to start the circuit again. Along that circular path, valves control how much water flows through different paths, thereby controlling loop and equipment temperatures and loop pressures. The ITCS has only three types of valves, though valves of the same type serve several different functions throughout each loop. Each of the independent loops has a

three-way valve that moderates flow between the racks of equipment that need cooling, and a line that bypasses those racks. This valve, called the System Flow Control Assembly Modulation Valve, provides a constant differential pressure across the system. Each loop also contains a pump shutoff valve that provides the ability to isolate a pump from water flow when the pump is not in use. Each loop also has a three-way valve controlling the water flow through a heat exchanger, thus controlling the temperature of the loop (i.e., more flow to the heat exchanger for a colder loop, less flow to the heat exchanger for a warmer loop). A unit

called the Nitrogen Introduction Assembly contains two separate two-way valves used to control loop pressure at the pump. The first, called the Nitrogen Introduction Assembly Introduction Valve, provides access to the ISS nitrogen system to maintain or increase the loop pressure via an accumulator in the pump package of each loop. The other, called the Nitrogen Introduction Assembly Vent Valve, allows the nitrogen in each ITCS accumulator to be vented into the cabin to reduce loop pressure.

The two ITCS loops in the LAB operate at different temperatures to support different cooling needs in various systems. The colder of the two, known as the Low Temperature Loop (LTL), operates at 9.4°C (48.9°F) whereas the Moderate Temperature Loop (MTL) operates at 17.2°C (63.0°F). These control temperatures are optimized for the cooling of different equipment in the LAB, but each TWMV is capable of controlling to a broad range of temperatures, limited by the capability of the heat exchanger that is providing the cooling and the heat provided by the equipment being cooled. The LTL services mostly the environmental and life support systems equipment and payload racks that require cooling to lower temperatures. The MTL services mostly avionics and electronics across a variety of systems. The dew point on the ISS is kept in the 8°C to 10°C (46°F to 50°F) range, meaning that water will condense on any surface colder than those temperatures. For that reason, the LTL lines are covered in thick insulation to prevent any moisture collection. Since the MTL operates at temperatures above the dew point, the MTL fluid lines are



**Figure 10.** Schematic of the LAB Internal Thermal Control System. In the LTL, cold water (dark blue) comes out of the IFHX and, if needed to adjust the temperature, mixes with warm water (purple) at the TWMV. The adjusted water flows to the heat loads. It returns through the System Flow Control Assembly, which regulates flow through the loads and the flow bypassing the loads to ensure steady flow rates throughout the system. After leaving the System Flow Control Assembly, flow proceeds via the Pump Package Assembly to the heat exchanger to reject the heat that the water has picked up. The MTL behaves the same way, cooling hardware that operates at higher temperatures. In contingency cases, the Loop Crossover Assembly can be opened between the loops to create one big loop using only one of the two Pump Package Assemblies. In the big loop configuration, the Regenerative TWMV allows warm water at the outlet of the MTL pump to warm the water flowing toward the MTL heat loads to ensure the MTL coolant is at the right temperature for the warmer loads. Not all modules in the US On-orbit Segment have crossover assemblies.

uninsulated. A pair of 8-port valves, together called the Loop Crossover Assembly, allow the two ITCS loops to be connected in series such that one pump can provide flow to a single, larger loop. This mode can be used if there is a problem with one of the pumps. In the single loop configuration, water flows through the LTL loads and then through the MTL loads. The water temperature at the outlet of the LTL loads is not usually warm enough to ensure that the fluid lines will remain above the ISS dew point; therefore, the water must be warmed before flowing into uninsulated MTL fluid lines. A water-to-water heat exchanger, called the Regenerative Heat Exchanger, transfers heat from the warmest water

in the system at the outlet of the MTL, to the cooler water at the outlet of the LTL to ensure water moving from the LTL lines to the uninsulated MTL lines is warmer than the ISS dew point. A three-way valve known as the Regenerative TWMV controls how much of the warmest MTL water passes through the Regenerative Heat Exchanger to control the resultant temperature of the water flowing out of the LTL and into the MTL. In the first years of LAB ITCS operation, the system was run as two separate loops, known as the dual-loop configuration. After an MTL pump failure in 2003, the ISS thermal community decided to preserve operational life on all remaining pumps by operating the ITCS in the



single-loop configuration. Operating in this fashion means only one pump is running at a given time, and is therefore experiencing wear and tear.

Heat is removed from some of the hardware using coldplates, as shown in Figure 9. A rack can house several coldplates, in which case the whole rack is treated as one heat load with a rack FCV that functions in the same way as TWMVs to allow for temperatures to be adjusted, depending on the need of what is in the rack (Figure 10).

## Conclusion

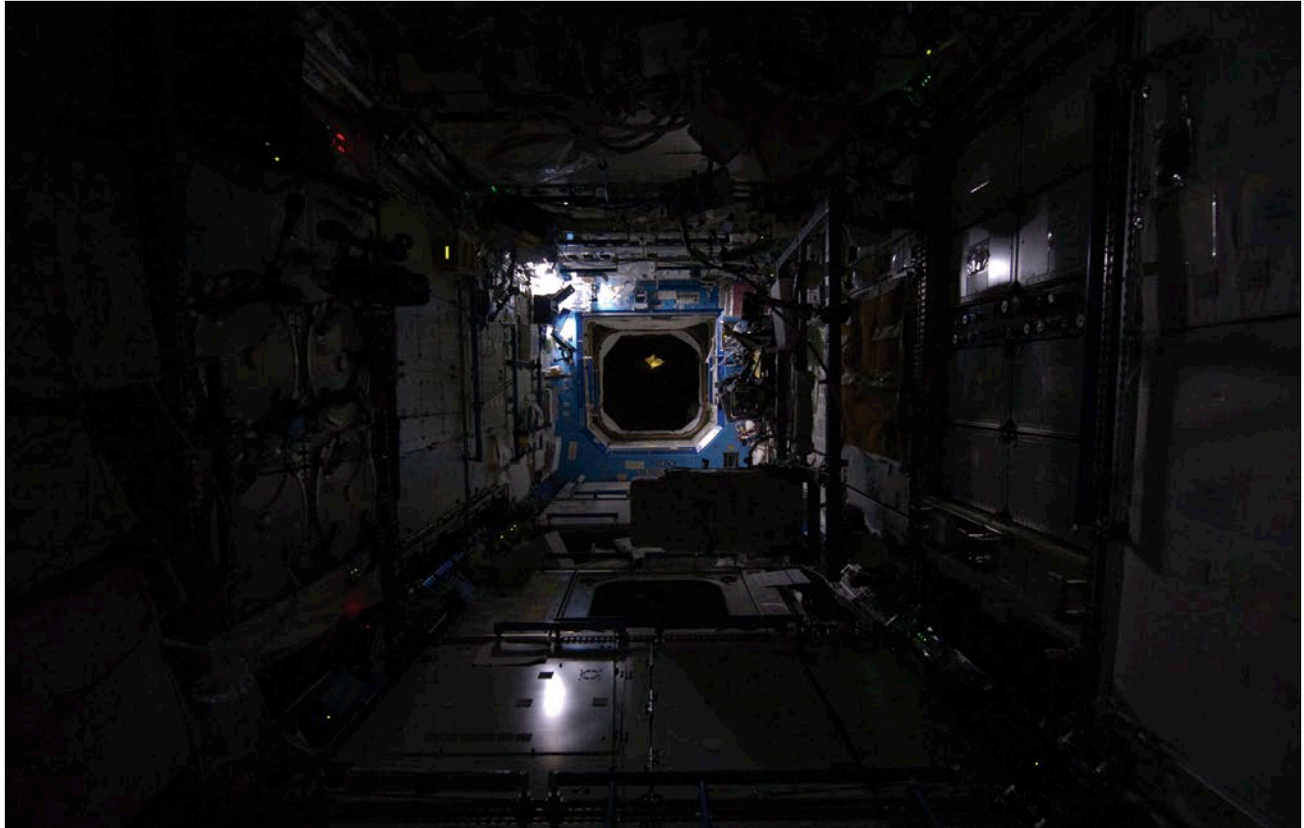
The thermal environment of space is extremely challenging to manage. The ISS has multiple thermal systems to help keep the space station from getting too hot or too cold. The systems employed on the ISS are actually similar to those used in terrestrial buildings. Fiberglass insulation in the walls or paint on a house are examples of passive thermal systems used every day. Heaters are also employed on the station and in the home to prevent areas from getting too cold. Most buildings and homes in hot climates have air conditioning, where heat is transferred to a fluid that, in turn, is radiated outside of the vehicle or building. One major difference exists between terrestrial heating and cooling systems and those employed on the ISS: when an air conditioner on Earth fails, a repairman can order parts and come fix it. When cooling fails on the ISS, every other system—from power generation, to computer controls, to the astronauts themselves—are put in jeopardy. Only the materials that are already in space can be used to make the

repair. In the end, the ultimate goal of both Earth-based systems and the ISS thermal systems is the same: to keep the structure and occupants safe and comfortable inside. The engineering challenge with the ISS was to have a thermal system that worked in the extremes of the space environment, worked with the first elements of the ISS, and was able to adapt as the structure grew and matured. The flight control team carefully watches and manages the various cooling loops as the heat loads (e.g., different experiments or numbers of astronauts) vary and as the space station orbit changes (e.g., when the beta angle gets above 60 degrees). The flight control team has also had to deal with significant failures in the system, such as when the pump that controlled ETCS Loop A failed, essentially removing half of the ISS-critical systems. Or when the FCV in the ETCS failed, which removed the ground's ability to control the loop temperature and thus provide adequate cooling to other ISS systems. Any number of failures elsewhere on the ISS could have meant the loss of the crew or spacecraft (for more details, see Chapter 20). As with so many aspects of life in space, something taken for granted most of the time on Earth requires thoughtful design and focused attention to detail in operation to enable humans to live in the utter darkness and extreme brilliance of space.



## Chapter 12 Day in the Life:

Empty House—  
Decrewing  
the International  
Space Station



Lights out. An empty US Laboratory module.

**As discussed in other chapters, the International Space Station (ISS) was largely designed to be controlled by operators from the ground.** This would allow crew members to focus their time on scientific research and not the “humdrum” daily activities required to keep the scientific laboratory running. However, many tasks require crew insight and hands-on actions, especially in the cases of repairing failed equipment and responding to emergency events.

What would it mean if, for some reason, all of the ISS crew members needed to return to Earth? Would all scientific research stop? Could the ISS even survive without a crew, and for

how long? In August 2011, the ISS Program was asked these questions.

On August 24, 2011, the Progress vehicle number 44P (i.e., the 44th Progress resupply vehicle in the ISS Program) was lost due to a problem in the engine of the Soyuz U rocket’s third stage. Although the loss of supplies being carried on a supply vehicle, such as Progress, would impact operations, the ISS Program continuously plans consumables to overcome the loss of at least one resupply mission (see also Chapters 1 and 14). The bigger impact to this loss was the similarity of the third stage of the Soyuz U rocket used to launch Progress cargo vehicles and the third stage of the Soyuz FG

rocket used to launch Soyuz crewed vehicles. Immediately following the Soyuz U third stage failure, Roscosmos State Corporation for Space Activities—the government body that oversees Russia’s space program—started an investigation into the cause. However, it was unknown how long the investigation would last and whether any corrective actions would need to be taken on the Soyuz U and Soyuz FG rockets.

Until the Soyuz U third stage failure was understood, the safety of launching new crews remained unclear. The crew on board the ISS was safe. However, Soyuz return vehicles have a limited lifetime. This presented the potential of needing to

return the current crew to Earth prior to the arrival of a new crew, thus decrewing the ISS and leaving it an empty house.

The ISS Program and operators around the world began a thorough, time-limited review of space station operations to determine any changes to vehicle configuration or ground systems needed to keep the ISS operational during a potential decrewing of unknown duration. This chapter outlines the history of potential ISS decrewing discussions, how the 2011 event response was developed, and the systems and operations changes that would have been enacted in the event the ISS was decrewed.

## History

Decrewing the ISS was not a new concept. The potential had existed ever since the first crew docked to the space station. In the early days, if a crew member became so ill that he or she had to return to the ground for immediate medical treatment, then the entire crew might have been forced to leave the ISS. With the advent of six-crew operations, it is more likely that at least one crew of three can remain on board. However, the ISS could become uninhabitable due to an off-nominal situation such as fire, depressurization, or major systems failure. These unlikely scenarios would not allow much time for preparation. With crew member safety being of the highest importance, the crew return vehicles will act as lifeboats to bring them home. Following an emergency, the ISS would be maintained and hopefully fully recovered in a best-effort capability using the technical

expertise that NASA and its partners have developed over years of spaceflight experience.

Planned decrewing of the ISS had also been discussed and documented multiple times. Early in the program, the planning of crew rotations sometimes ran into issues with the logistics of launch vehicle processing, meaning that the potential need for one crew to return before a replacement arrived existed, but it never actually occurred. At that time, the small-but-growing space station had been operated uncrewed for its first 2 years. Decrewing the ISS dealt a major impact to assembly operations and scientific research since crew members were required to perform many of these operations. However, decrewing was not thought to be a major concern for the overall survival of the station itself due to the design goal of being remote controlled. Over the years, barring any issues with vehicle upgrades or accidents, this planning became a well-oiled machine and is no longer much of a concern. Decrewing the ISS was also a topic following the Space Shuttle Columbia accident. The shuttles provided the capability to launch and return crew members, and deliver large quantities of consumables to the ISS. The Space Shuttle Program performed a lengthy investigation and recovery effort; thus, the ISS partnership was able to keep the ISS staffed by reducing crew size and relying on Russian capabilities to launch astronauts and supplies. At the time of the Progress 44P accident in 2011, which followed the retirement of the Space Shuttle fleet, no alternative to the Russian Soyuz crewed spacecraft to launch or return astronauts existed.

The outcome of many of these discussions were documented in operational products, including procedures and Flight Rules. These products would be used and built upon to develop an operational philosophy for a decrewed space station.

## Framing the Discussion

In many ways, it was up to the operations teams to determine how to continue operating without a crew on board. But first, the operations team and the ISS Program developed a set of priorities to drive the discussion and decisions that would result in the decrewed space station configuration.

The high-level priorities, in order, were:

1. Keep the ISS safely operating until a crew could return, and beyond.
2. Prevent the loss of critical hardware and maximize critical system redundancy. This included performing preventative maintenance on systems whose expected lifetime would expire before a crew would return, and potentially using temporary power or data extension cables to increase flexibility following failures.
3. Prevent loss of scientific data, and consider delaying the start of new scientific research that would be lost if the crew was not available to finish it.
4. Optimize the ISS configuration to allow for an efficient return of a new crew.
5. Continue scientific research that could be controlled from the ground.

S	M	T	W	T	F	S	
4	5	6	7 Today	8	9	10	SEPT
11	12	13 Prelim Recs	14	15	16 26S Undock	17	
18	19	20 Final Recs	21	22	23	24	
25	26	27 Prelim Config	28	29	30	1	OCT
2	3	4 Final Config	5	6	7	8	
9	10	11 Plan Approval	12 42P Undock	13 Unmanned Sim (TBR)	14	15	
16 45P Dock	17 IMMT Go/No Go	18	19	20 Decrewing	21 Prep	22	
23	24	25	26	27	28	29	
30 28S Dock	31	1	2	3	4	5	
6	7	8	9	10	11	12	NOV
13	14	15	16	17 27S Undock	18	19	

**Figure 1.** Initial schedule for the 2011 ISS decrewing assessment. In the schedule, IMMT refers to the ISS Mission Management Team (see Introduction), 27S and 28S refer to the 28th and 29th crewed expeditions, respectively, and TBR indicates the date is To Be Reviewed.

Once these priorities were agreed to and established, the combined operations, engineering, and program teams set out to determine the best ISS configuration for decrewed operations. A lead flight director was assigned to integrate the operational aspects, develop a review schedule, and outline expectations for the team.

At a high level, the team focused on the time available and actions required prior to decrewing, establishing the ISS and ground systems configuration, the operations plan (including emergency response) during decrewed operations, and developing a plan to recrew the ISS

once the launch vehicle safety was reassured. A notional schedule (see Figure 1) was pulled together. This schedule outlined the 12 weeks that were available for the assessment. If, in the future, the potential to decrew the ISS arises again, a similar schedule would be used.

This timeframe allowed approximately 1 month to develop the recommended configuration. Once complete, the recommendation would be taken to the ISS Program for review and, hopefully, approval. One month prior to decrewing the space station, the ISS Mission Management Team (see also Introduction) would give

final approval to implement the decrew configuration, which the team estimated would take 4 weeks of non-dedicated crew time—meaning the crew would continue scientific research, as well.

Using these priorities, areas of focus, and schedule, the team divided into multiple groups to quickly assess the actions required. These groups jointly reviewed overall status biweekly, looking for concurrence on recommendations and requesting any assistance needed. The lead flight director then officially reported the status to the ISS Program management on a weekly basis.

## System Changes

Using the priorities established above, the decrewed ISS configuration was developed to ensure the station would continue to fly safely and perform scientific research. Although there would not be a crew on board to respond to emergency situations or repair broken equipment, many of the decrewing actions dealt with minimizing the potential for these events or increasing the ground operators' ability to handle these situations.

The already-docked Progress vehicle, 42P, would be configured so that it could be undocked remotely by the Russian flight control team, if needed, yet continue to provide the ability to perform debris avoidance maneuvers (see Chapter 8). Similar to the Soyuz vehicle, this Progress had limited lifetime and would need to be undocked before posing a risk to the ISS, or before it would be unable to complete its mission. Also, undocking the Progress once its resources were expended would provide an additional open docking port for either a new Progress full of supplies or a redundant docking port for a returning crew. The most critical step in this preparation would be to have the crew remove the clamps that helped hold the vehicles together. Prior to its undocking, the ISS would be reboosted to a higher altitude to make use of available Progress propellant and prolong the orbital lifetime of the ISS in the event of a major delay of fuel resupply.

Although the ISS has been designed to minimize the risk of an on-board fire, there is still the low likelihood that one could occur (see also

Chapter 19). Since the crew would not be available to fight a fire, the risk would be further minimized by powering down non-essential equipment (based on priorities). This non-essential equipment includes crew-tended payloads and crew-support equipment such as the toilet.

The crew also responds to ISS rapid depressurization emergencies potentially caused by orbital debris impacts by closing hatches between modules, which will hopefully isolate the leak to a single module. Initially, the team believed the best decrew configuration would be to isolate each module. Therefore, if a module started to depressurize, only that module would be affected. However, analysis of the isolated configuration for longer durations showed that a potentially large variation in pressure and temperature would occur between the modules. To keep the atmosphere of the ISS within temperature and pressure limitations, it would be best to keep air moving between the modules. The decrew configuration would have the crew close hatches prior to leaving, but Intermodular Ventilation (IMV) (see Chapter 19) would be left enabled, meaning vent ports and fans between modules would be left open and blowing. In the event of a depress, automatic software would deactivate the fans and close the vent ports, thereby isolating all of the modules. Leaving IMV enabled would assist with maintaining a uniform atmosphere between modules and could assist in some emergency events (see below).

Humidity levels in the ISS atmosphere were another concern. Normally, water is added to the ISS

atmosphere as the crew exhales and perspires. Humidity is removed from the atmosphere by the ISS Thermal Control System (TCS) to keep the crew comfortable, prevent condensation from damaging the equipment, and add to recycled water stores. This water is sent to the Regenerative Environmental Control and Life Support System (ECLSS) (see Chapter 19) for recycling. However, little to no water would be added to the atmosphere without a crew on board, and there was no safe controllable way for ground controllers to release water to increase humidity. Low humidity is a concern to the ISS critical electronics as it can lead to the buildup of static electrical charges. These static charges could potentially cause electrical arcs that would damage critical systems. These arcs would be similar to the shocks that can be felt when touching a metal door handle on a cold, dry winter day on Earth. To prevent drying out the ISS atmosphere too much prior to the crew leaving, the internal cooling loop temperatures would be raised to stop condensing water out of the atmosphere. The Environmental and Thermal Operating Systems (ETHOS) officer would need to actively monitor the fine balance of maintaining enough humidity in the atmosphere while preventing condensation on cooler surfaces. It is important to note that the ISS did not have a humidity sensor; thus, all of the information ETHOS would use for this monitoring would be based on temperature data and analysis. If the analysis was wrong and the atmosphere dried out, the ground team would not be able to recover the correct humidity levels.

Maintaining the viability of the Regenerative ECLSS (see Chapter 19) was a major concern for the team. Although the Regenerative ECLSS is an engineering marvel that consistently recycles a large majority of the water on the ISS and provides clean drinking water and breathing oxygen, it is still a new technology that can be temperamental and require manual input to keep it running. Additionally, part of the

closed-loop ECLSS is the crew. They inhale oxygen and drink water that is provided by the system. In turn, they exhale carbon dioxide and produce water in the form of perspiration and urine, which is taken into the system for cleaning. Without a crew on board, this closed loop is broken. One option for the decrewed configuration would be to deactivate the Regenerative ECLSS and let it sit idle after draining out

the fluids or leaving the fluids (e.g., water or urine) stagnant. Removing all fluid from the system would be time consuming and difficult, and success could not be guaranteed. Additionally, the engineering team was concerned that parts would become damaged and need to be replaced if the Regenerative ECLSS was dried out, potentially leading to a long period of fine tuning the system to get it running again. If fluid was

## Preparing to Abandon Ship

*Colonel Mike Fossum, Commander, Expedition 29*

The crew of Expedition 28 was following the launch of the 44th Progress resupply vehicle (44P) with great interest because we knew the ship would bring not only necessary supplies, but also fresh food and care packages from home. When we heard about the launch failure, the crew huddled together to discuss the events. We were initially disappointed in the lost supplies; however, within a few minutes, we realized the booster used to get the Progress cargo ship into orbit was very similar to the one used to launch humans on the Soyuz spacecraft. The investigation of a rocket failure that scattered debris across many hundreds of miles was going to take time. Perhaps a lot of time. We knew immediately this might mean our stay on the ISS could be extended for as long as the on-orbit lifetime of our Soyuz spacecraft would allow. And it could mean we would be forced to leave before the next crew arrived. The ISS—an amazing orbiting laboratory representing the hopes and dreams of 15 partner nations—could be without a crew for the first time since Expedition 1 began in 2000. The enormity of the situation quickly became clear. We had a new mission: Steel ourselves for a longer-than-intended stay, prepare the space station for operations without a crew on board, and do whatever we could to help prepare the next crew to take control of the ship with little to no handover time.



**Figure 2.** Astronaut Mike Fossum installs an electrical bypass jumper to provide a redundant power feed for the MBSU-1 in case the ISS had to be left uncrewed.



left stagnant, microbial growth and chemical changes to the fluid could occur. Think about the drains and water lines of a house that has been sitting vacant for an unknown amount of time. However, the Regenerative ECLSS was designed with multiple recirculation loops internal to processing equipment. These loops were included to allow for start-up transients or failures where the output of the system did not meet quality

standards. In these cases, the output would be rerouted back to the input and sent through the system again, in an attempt to continue to further clean the water (see Chapter 19). The ETHOS controllers would periodically use these recirculation loops to move water through the Regenerative ECLSS for the duration of a decrewed configuration. This would keep the system running and prevent stagnant fluid concerns.

Prior to decrewing, the crew would install multiple electrical power and thermal cooling jumpers to maximize critical system redundancy. At the time of the Progress 44P accident, the firmware controller for Main Bus Switching Unit (MBSU) (see Chapter 9) 1 was degraded. A jumper would provide power from a pair of parallel internal Direct-Current-to-Direct-Current Converter Units, since this increased the risk of MBSU 1

Emotions on board ran the gamut. Members of the Expedition 27-28 crew were supposed to head home in a couple of weeks, but immediately started hearing rumors of a 2-month extension. Some were happy about having a longer stay, but some had already started thinking about returning to the delights of hot showers, real food, and loving families. I told my family that they would hear a lot of rumors, but don't expect me home for Thanksgiving, Christmas, or New Years. Although nobody could know for sure, I figured it was better to just set the expectation early for both my family and myself.

Meanwhile, the ground team, led by Flight Director Scott Stover, started working the plans for us to prepare the ISS in case we needed to leave it without a crew on board. The ISS is an amazing ship, but it was intended to be operated with a crew to help keep it running and recover critical systems in the event of failures. Our workdays accomplishing the myriad of science objectives became interspersed with just-in-case activities, such as running electrical jumper cables as thick as your forearm to provide a secondary source of power in case a critical electrical component failed (Figure 2). We went about these tasks with the grim realization that we could not protect for every possible thing that could go wrong. Without a crew on board, we were at risk of losing the ISS.

While the specialists were working in Houston, Moscow, and around the planet to figure out how to protect the vehicle, we started thinking about how to help prepare the next crew members to be successful when they

finally arrived. Our preflight training is very good, but many details associated with living and working on the Space Station are impossible to simulate and train on the ground. Under normal crew rotation schedules, we hand over those "tricks of the trade" during the 2 to 4 months, which we overlap on the ISS. By the time the senior crew departs, the junior crew is ready to take the lead, then train the incoming new crew. Knowing we would not have the benefit of significant (if any) handover training time, we started recording videos to show the new guys how to get the job done. This included a wide variety of activities such as compressing/sealing nasty wet trash bags, cleaning hard-to-access filters, and configuring the confusing pulmonary function test equipment. By the end, we sent down more than 22 hours of instructional videos.

In the end, everything worked out very well. The Expedition 27-28 crew returned home with only a 1-week delay. As the Commander of Expedition 29, I knew we were shorthanded for a couple of months; however, were ready when the crew of Expedition 29-30 (Dan Burbank, Anton Shkaplerov, and Anatoly Ivanishin) arrived on Soyuz 28. We didn't sleep much during our 6 days of sharing the ISS, but thanks to the excellent preparation from the ground team and the crew's dedication to extra training and video reviews, they were ready to take charge as we closed the hatch and headed home. Our homecoming was delayed only a week, and I arrived home to my family just in time for Thanksgiving. And a joyous homecoming it was!

failure and loss of power to half of the critical computers and cooling equipment on the ISS. A jumper could provide power from either MBSU 1 or MBSU 4 to these critical components. Additionally, critical power and computer equipment in both the Laboratory Module and Node 3 is nominally cooled by the Moderate Temperature Loop (MTL) of that module (see Chapter 11). In the event of an MTL leak during crewed operations, the crew would jumper critical equipment so that that it could be cooled by the Low Temperature Loop (LTL). For decrewing, half of the critical equipment would be preemptively jumpered to the LTL, meaning that a leak on either the MTL or the LTL would impact only half of the critical equipment. It is also important to note that in this jumpered configuration, the ground-controlled capability to integrate the MTL and LTL into a joined single loop is still possible; therefore, failure of a single ITCS pump would not cause the loss of cooling to critical equipment.

The team looked into multiple ways to maximize ground insight and command capabilities to the ISS. At the time of the Progress 44P accident, all commanding to the ISS was through the S-band systems or Russian Ground Sites (see Chapter 13). To provide additional redundancy, the team developed a way to connect the crew's Portable Computer System (PCS) (see Chapter 5) commanding laptops to the ISS Joint Station Local Area Network (JSL). Once connected to the JSL, a flight controller would be able to remotely log into

the PCS using the ISS Ku-band system and then send commands from the PCS. The ISS Ku-band system was later updated to provide standard commanding without the need to log into a PCS. As an interesting sidenote, when originally brainstorming ways to command through Ku-band, the team recommended using the humanoid robotic payload Robonaut to physically interface with a PCS on board. This would have required a lot of development in a short amount of time since Robonaut operations were in their infancy at the time. As it turned out, the remote log-in capability was easier to implement.

Additionally, the JSL is the gateway to the Ku-band system; therefore, ground control relies on an on-board laptop server. Nominally due to internet protocol and device identity limitations, only one laptop is configured as a server. If that server fails, the crew must deploy a new laptop. The JSL engineering and ops teams developed a way for a second laptop server to be deployed and powered in a standby, non-interference way. In this configuration, if the primary JSL server laptop failed, the PLug-in-plan Utilization Officer can easily configure the standby server to the primary role, thus restoring the JSL.

Another hurdle in being able to operate the laptops from the ground is related to their power source. On-board laptops receive power from Utility Outlet Panels (UOPs) (see Chapter 5). If a UOP loses upstream power but is later recovered, it will not output power to downstream equipment without

the crew physically cycling a switch on the UOP, much in the way a Ground Fault Circuit Interrupter works on many household electrical outlets. In a decrewed configuration, it was important that the PCS and JSL laptops that were acting as backup command capability could be repowered after a potential loss of upstream power. To offer this functionality, a UOP Bypass Jumper was installed to provide power directly from a Remote Power Control Module (see Chapter 9) to the laptops. This would allow the Station Power, Articulation, Thermal, and Analysis officer to remotely control power going to the laptops. Interestingly enough, the UOP Bypass Jumper was developed early in the life of the ISS when it was determined that the original electrical grounding safing function of the UOP did not work with the Robotics Work Station (see Chapter 15). Although the grounding issue was corrected, the UOP Bypass Jumper was retained on board in case of unexpected needs, such as decrewing the ISS.

The crew is normally the on-scene eyes and ears of the flight control team. Video cameras or laptops with cameras were set up to supply overviews of each module, which would provide visual and auditory insight to the ISS during decrewed operations. The Communications Radio frequency Onboard Networks Utilization Specialist would then be able to cycle through available camera views to assist the flight control team in identifying off-nominal situations. This would be greatly beneficial in the event of a fire or rapid depress.

## Emergency Response

As discussed above, the crew takes a leading role in responding to emergency events on board the ISS. The team thoroughly reviewed emergency responses to develop a strategy for the flight control team to respond to each kind of emergency without a crew available.

### *Rapid Depress*

As stated above, prior to leaving, the crew would close hatches between modules while the IMV was left enabled. If on-board sensors detected a depressurization, automatic software would close the IMV valves, thus isolating the modules. If a depressurization is too slow to trigger automatic software, the flight control team would manually command the Rapid Depress emergency response—an action usually taken by the crew. This would limit the depressurization to the leaking module or modules. Without a crew on board, the leaking module could not be repaired. At that point, the flight control team would unpower equipment in the affected module. If the affected module contained critical equipment, the flight control team would attempt to keep the critical equipment operational on a best-effort basis.

### *Toxic Atmosphere*

As discussed in Chapters 11 and 19, one of the most dangerous events that can potentially occur on the ISS is the rupture of a TCS heat exchanger between the external and internal TCS loops. If this were to happen, the ammonia in the external loop would flood the internal loop and quickly

fill the ISS atmosphere to lethal levels. Additionally, the pressure from ammonia entering the atmosphere could overcome ISS design limitation. However, a system of valves provides Positive Pressure Relief (PPR) by venting excess pressure overboard. This PPR is available only in certain modules. Many redundant levels of hardware design and hardware and software active controls prevent the heat exchangers from freezing, which could cause them to rupture. However, since the potential is so dangerous, the crew and ground teams train extensively to respond to a heat exchanger rupture. When crew members are on board, their response is to evacuate the United States On-orbit Segment (USOS), which is the only segment directly impacted by the ammonia. They do not have time to close hatches between USOS modules. However, the automatic toxic atmosphere software response does close IMV valves between modules. With the hatches left open, all USOS modules have PPR available. In a decrew configuration, the USOS hatches would be closed and automatic software that closes IMV valves would leave some USOS modules isolated with no access to PPR. If one of those modules contained the ruptured heat exchanger, that module would be exposed to pressures that could catastrophically damage the ISS. The team decided the best course of action was to inhibit the toxic atmosphere emergency software automatic response, which would leave the IMV valves open even if an ammonia leak was detected. This would provide PPR to the entire USOS, and would be similar to the crew response of not

closing hatches. If the flight control team observed other potentially toxic substances via downlink cabin video or telemetry, the affected modules would be isolated by closing IMV to those modules.

### *Fire*

Automated software response to a fire is to shut down both intra-modular ventilation and IMV fans (see Chapter 19). This is based on the fact that there is no convection in microgravity. Without convection or forced ventilation, fires will consume the locally available oxygen and then extinguish due to a lack of additional oxygen (see “Convection—Gravity’s Cooling Mechanism” in Chapter 11). Following ventilation shutdown, a crew would use air sampling equipment to pinpoint the location of a fire. Once the location was identified, equipment in that location would be unpowered to remove possible ignition sources. The crew would then investigate this equipment further to determine the cause of a fire, and set up equipment to remove smoke from the atmosphere. Flight controllers would not be able to pinpoint fire sources or perform detailed equipment inspections without a crew on board. In this scenario, the team determined the best fire response would be to allow the automated software to terminate ventilation. The ground team would then review available telemetry, including cabin video, to determine whether any equipment show off-nominal signatures. If telemetry pointed to a potential fire source, that equipment would be unpowered. Whether or not a potential source

was identified and unpowered, the flight controlled team would wait approximately 30 minutes to an hour for a fire to extinguish, and then reactivate ventilation to maintain the ISS atmospheric conditions and dilute any smoke in the cabin. If the fire reignited, ventilation would again be shut down. Additional scrutiny and powerdowns would follow prior to reactivating ventilation.

## Recrewing

Per the ISS Program priorities, the team also took time to determine what actions, both on the ground and on board ISS, would best prepare for the arrival of a new crew to a decrewed station. This included identifying any consumables or equipment that would need to be launched with the new crew members, or prior to their arrival. Additionally, the team identified a list of items that the crew would need for quick access upon entering the station. This equipment included tools, air sampling devices, and personal protection equipment (i.e., gloves, goggles, masks) in case of an emergency on board while the space station was uninhabited. The current crew would gather these items and stage them in the Russian Segment where the new crew would be docking. A recrewing procedure and timeline was developed to return the ISS to a nominal configuration in the same way the team developed a procedure and timeline for implementing the decrewed configuration.

## Training

Two important aspects of training were associated with developing the decrewed configuration. The first concern was crew training. In addition to preflight ground training, new crews received “handover” training from the current space station crews. This training revealed the most up-to-date configuration of the ISS, and provided hands-on tips and tricks to performing common procedures. If decrewing happened, the new crew would not have the benefit of this handover training. With that in mind, on-board crew members began making video recordings of common procedures, including voice-overs of the topics usually included during handover. They also recorded video tours of the ISS helping the ground teams understand the exact physical configuration of station systems and stowage. These videos were added to the training of the next crew and they continue to be used for future crew training. Additionally, the next-to-launch crew members aided in the development of the decrewing and recrew procedures. This added to their familiarity with the procedures and would greatly benefit the team in the event the ISS was decrewed.

Second, the flight control team executed a decrewed configuration simulation. To do this, the ISS training team configured the ISS simulator to the expected decrew configuration. A team of experienced operators were then put through an exercise to respond to simulated

equipment failures and emergency situations. This was used to test the decrew configuration and operational response. Although the team learned that some procedures would need to be modified, the simulation showed that the flight control team could maintain the ISS in a decrewed configuration.

## Conclusion

When Progress 44P was lost due to a problem in the engine of the Soyuz U rocket’s third stage, the ISS Program was faced with the possibility of needing to leave the ISS uncrewed for an unknown amount of time. As seen in the past, the program, engineering, and operations team quickly stepped up to the challenge.

First, priorities were defined. These included maintaining ISS safety and operability, increasing ISS system robustness, and assuring the capability of flight control teams to respond to off-nominal situations, thus enabling a returning crew to quickly recover nominal operations and continue scientific research. Using these priorities and building on previous discussions and documentation, the ground teams developed procedures, plans, and training to place the ISS in the best configuration to support uncrewed operations and return to a crewed configuration.

The Russian Space Agency was able to determine the cause of the Progress 44P accident and return to

flying both Progress and the Soyuz vehicle before the need to decrew the ISS. However, having met the initial review and product plan, the team was prepared to implement the decrewed configuration and support the ISS, as necessary. If the potential to decrew the ISS arises again, a similar review will build off the plans, products, and lessons learned from this event.



## Chapter 13 **Systems:**

Communications  
and Tracking—  
The Vital Link  
to the International  
Space Station



NASA astronaut Jim Voss and Russian cosmonaut Yury Usachov are having some fun with Mission Control as they demonstrate their alternative means for communicating with each other on the International Space Station during the second crewed increment.

**Some of the most iconic statements in human history such as “Houston, Tranquility base here. The Eagle has landed!” would not have been possible without a good communication system—an essential part of any crewed or uncrewed spacecraft.**

It is critical that the communication system works. It is the link between the spacecraft and its crew and the flight controllers on the ground. Without a good communication system, the crew will not have adequate insight into the condition of the International Space Station (ISS) and the ground may not be able to help during nominal events or, more importantly, during emergencies. Spacecraft communication systems move information from one place to another. Information on the ISS needs to move between modules of the spacecraft, between the spacecraft and visiting vehicles flying in proximity, and between the spacecraft and the control centers on the ground.

The types of ISS information that need to be moved include:

- Commands and computer configuration data
- Health and status data on the various systems on the ISS
- Health, status, and ranging information of visiting vehicles
- Science experiment data
- Two-way voice and video
- Alarm tones

The communication equipment is known as the Communication and Tracking (C&T) system because it can be used to follow, or track, the spacecraft. This chapter will discuss the essential aspects of the C&T system. The main communication systems on board the ISS are organized into two prime areas: Radio Frequency (RF) and Baseband. A total of eight types of communication systems are located within these two main areas. Table 1 summarizes the key systems and the number of each type.

**Table 1.** A summary of the different communication systems on the ISS. The RF systems are broken down by the portion of the electromagnetic spectrum that each uses (defined below). The numbers in parenthesis indicate how many of each system exists.

<b>Types of Communication Systems on the International Space Station</b>	
■ S-band	} RF
■ Ku-band	
■ Ka-band	
■ L-band (for GPS)	
■ Ultra-high frequency (UHF)	
■ Very-high frequency (VHF)	} Baseband
■ Audio	
■ Video	

\* Includes the original ISS S-band system known as the Early Communication System, a temporary communication system used during the first 3 years of space station operations until the main systems were activated.



## Radio Frequency Communication Systems

Conventional communication systems dating back to the first spacecraft—Sputnik, launched by the Russians in 1957—use RF links. Radio waves of varying frequencies are the same as those used by car radios, televisions, and cell phones. They are generally ideal for communicating with spacecraft because they tend to use minimal power, and the longer wavelengths can easily penetrate the Earth’s atmosphere. But a trade-off exists between frequency and the amount of information the signal can contain. Higher-frequency radio waves can carry more information but are more susceptible to signal degradation as the waves travel through the atmosphere. For example, satellite TV systems operate in the Ku-band;

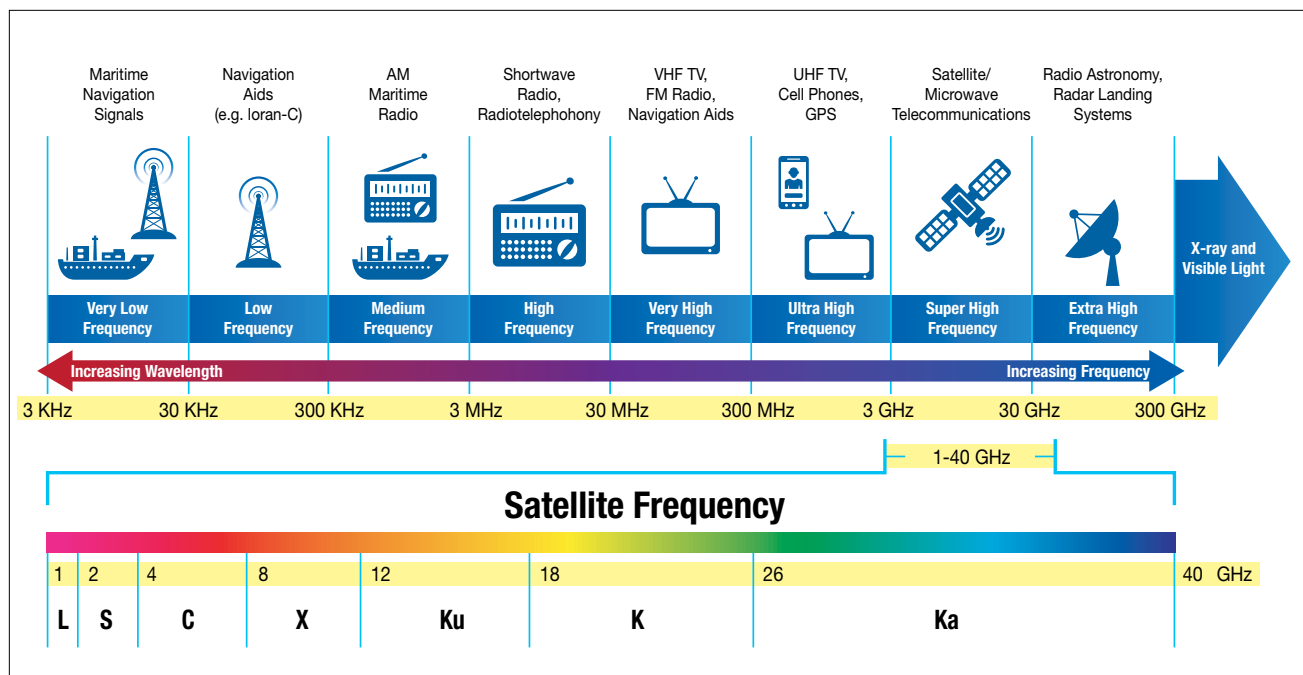
the radio waves are susceptible to heavy rain showers when the signal might be lost temporarily. The ISS uses different systems in different bands, depending on the specific need. Figure 1 depicts the electromagnets spectrum with the key bands used by the ISS.

The main communication path relies on the NASA Tracking and Data Relay Satellite (TDRS) system, whereas the VHF link provides a direct radio transmission between a ground station and the ISS. The TDRS system consists of a number of satellites in geosynchronous orbit about the Earth that provide a relay link for the S- and Ku-bands between ground stations and the space station. With the satellites being distributed around the planet, the ISS can be in continuous communication with Mission Control.

## S-band

The term S-band refers a specific range of radio frequencies at which the communication systems operate. The S-band range is a subset of the super-high-frequency range; specifically, 2 to 4 gigahertz. This type of RF communication system is the most common on the ISS.

The S-band communication system is comprised of three boxes referred to as Orbital Replacement Units: the Baseband Signal Processor, the Transponder, and the Radio Frequency Group (RFG). See Figure 2. The Orbital Replacement Units are mounted outside the ISS. One set is mounted on the P1 truss segment and the other set is mounted on the S1 truss segment. Only one set is used at a given time, and the two sets are alternated.



**Figure 1.** The RF spectrum used by ISS communication systems. By convention, the electromagnetic spectrum has been divided into specific bands. Several bands were delineated by their frequency range—high, very high, ultra, etc.—but several bands were also classified into smaller subdivisions and indicated by letters of the alphabet.

## Keeping the Lines of Communication Open

The official name of the ISS S-band communication system is the Assembly Contingency Subsystem. Originally, the S-band system was intended to be used only during the ISS assembly sequence and, after that, only in contingency cases. The Ku-band system was intended to be the primary communication link for the ISS. To defer costs, the build-up of the Ku-band system was extended over more years than originally planned. The S-band system continues to operate as the prime communication system for the ISS. The Ku-band system is used primarily to support ISS utilization.

The S-band system is used to send commands from control centers around the world to the ISS. Because of this, the system is designated with the highest level of criticality. The second S-band system is activated and configured as a “hot” backup for critical operations where an unexpected failure of the S-band system would threaten the safety of the ISS crew members, spacecraft, or mission objectives. Upon a failure of the primary system, the communication link is recovered in a minimal amount of time (~40 seconds). The S-band system is also the primary means of sending telemetry data from the ISS to the ground. The telemetry data are sent to the ground in real time to support operations. These data can be stored on virtual recorders on board the ISS and sent down later.

Another critical function of the S-band system is to provide two-way voice communication with the ISS crew members and the control centers around the world. The S-band system has two separate voice channels referred to in operations as Space-to-Ground (S/G) 1 and S/G 2. Although interchangeable, the channels are allocated specific uses that are defined in operations policies.

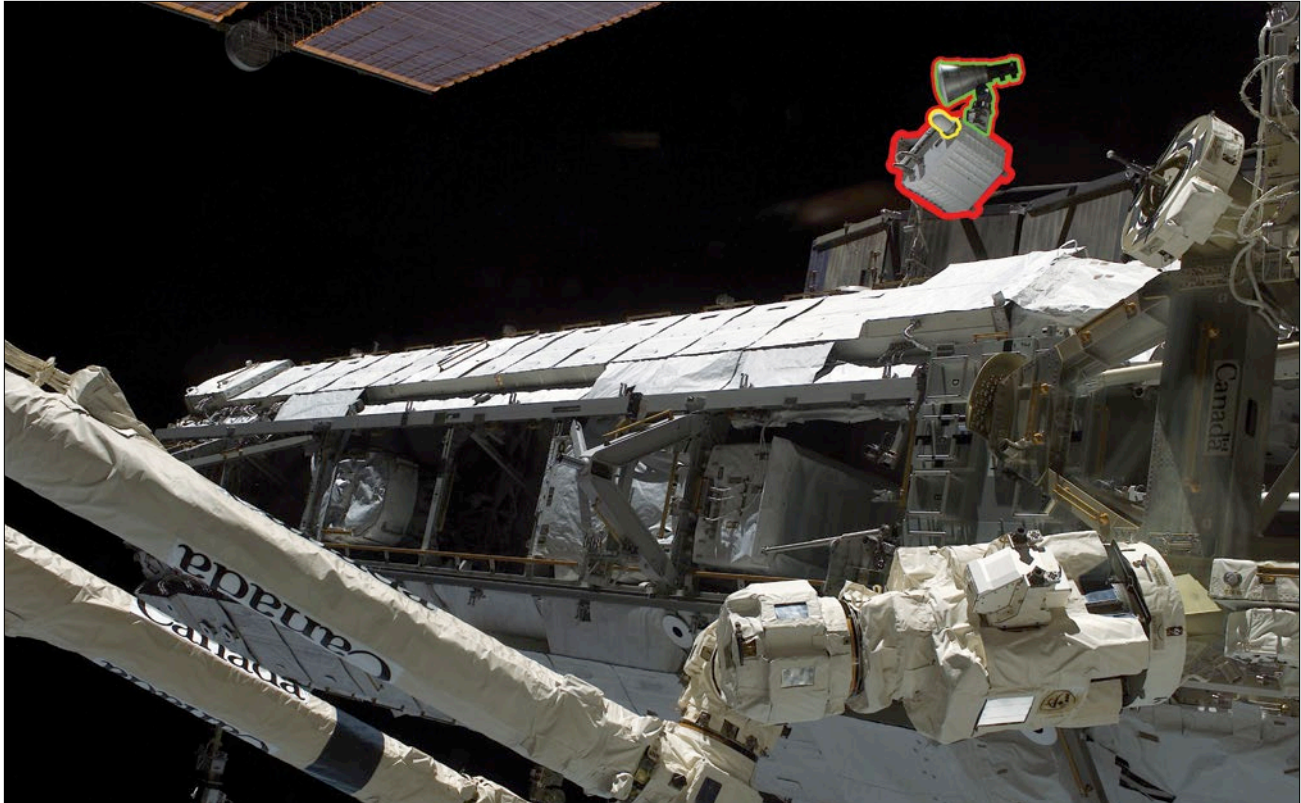
Software files that can be used by the on-board computers and records containing data about the ISS can be exchanged between the vehicle and the ground using the S-band system. Almost 300,000 individual pieces of data (e.g., temperature, energy level of a battery) have been designated for possible radioing to the ground. However, this represents only a subset of the data available on the ISS. About 10% of those values can be sent down via S-band every 10 seconds. Sometimes, the flight controllers need to look at these additional data. Therefore, bulk quantities of unprocessed data can be retrieved directly from memory in the on-board computers. This data retrieval is useful in troubleshooting a malfunctioning piece of equipment or misbehaving computer software without exhausting the available bandwidth all the time.

The S-band system is capable of being operated in two modes: a high-data-rate (HDR) mode and a low-data-rate (LDR) mode. The HDR mode consists of a forward link (i.e., transmission to the ISS) of 72 kilobits per second (kbps) and a return link (i.e., transmission from the ISS) of 192 kbps, and this mode simultaneously supports a pair of

two-way voice channels (S/G 1 and S/G 2). The term “high” is relative as, these days, most people carry RF communication devices that communicate at speeds significantly faster. For example, depending on the city, carrier, and plan, one can expect smartphone download speeds of at least approximately 3 to 10 megabits per second (mbps)—about 15 to 52 times faster than the ISS S-band system. The LDR mode consists of a forward link of 18 kbps and a return link of 24 kbps, and supports one two-way voice channel (S/G 1). This is slower than an old dial-up modem, which had speeds of 56 kbps. Originally, link speeds were 6 kbps and 18 kbps, respectively, with no voice channels. Later, the S-band system was upgraded, primarily to add one two-way voice channel to the LDR mode.

HDR is the primary operation mode. This mode requires the use of the high-gain antenna (HGA) located in the RF group. The HGA is a steerable antenna and needs to be pointed precisely at the TDRS being used to relay the signal from the ISS to the ground. The data used to point the HGA originate in the Guidance, Navigation, and Control (GNC) Multiplexer/DeMultiplexer (MDM) and are sent to the Command and Control (C&C) MDM where they are converted to commands for the RFG (see Chapters 5 and 7). The commands are automatically sent to the RFG once per second to keep the HGA pointed at the correct satellite as the ISS orbits the Earth.

If computers are not able to point the HGA due to a failure of its gimbal motors or a failure preventing the pointing data to be generated or sent to the RFG, then the flight control team will use the LDR mode. The



**Figure 2.** The S-band RFG on the S1 truss segment, with the HGA and LGA highlighted.

LDR mode uses a hemispherical antenna. This antenna is not steerable and therefore does not depend on the GNC or C&C MDMs. However, its field of view is limited; therefore, the amount of time this antenna is in a line of sight of a TDRS satellite is also limited. For this reason, and because of the slower data rates, the LDR mode is used for contingency purposes only.

A total of four operating modes are possible with HDR and LDR modes on each of the two strings of S-band. The modes can be changed manually by the flight control team on the ground or by crew members on the ISS. Generally, only one mode is used: HDR on one of the strings of S-band. The other modes and string act as a backup configuration.

Fault detection, isolation, and recovery software, which can detect whether a component fails and then reconfigure to a backup unit, can also change the mode.

### Ku-band

The Ku-band system is officially known as the Space-To-Ground Subsystem and operates at a forward link frequency of 13.7 MHz and a return link frequency of 15.0 MHz. This system was designed for and intended to be the prime communication system for the ISS precursor: Space Station Freedom. The Ku-band system was redesigned when the plans for Space Station Freedom changed to the ISS (see Introduction). The redesign was

needed to accommodate the higher radiation environment encountered at the orbit in which the ISS would fly (see Introduction). In the beginning of ISS operations, the forward link operated at 3 mbps and the return link operated at 50 mbps. Although these data transfer rates are significantly higher than the S-band capacity, there was a growing need to have more bandwidth, especially to accommodate some of the planned payloads on the ISS. Upgrades that were made to ground systems allowed the downlink rate to increase to 150 mbps and the uplink rate to 6 mbps. In 2007, NASA completed a major upgrade of the Ku-band system that boosted the forward link rate to 25 mbps and the return link rate to 300 mbps. NASA engineers are exploring options to further increase



**Figure 3.** STS-132/ISS-ULF4 mission specialist Steve Bowen works to install the backup Space-to-Ground Antenna (the white radio dish near the top left of the figure) on the Z1 truss (located next to the original antenna, which is angled to the right).

the Ku-band return link rate as science experiments on the ISS require faster and faster return link rates.

The ISS has two Ku-band systems; only one system is used at a time. The Ku-band system in its current state consists of the Ku Communications Unit (located inside the ISS) and the Transmitter/Receiver/Controller and Space-to-Ground Antenna (both of which are mounted outside the ISS). See Figure 3.

The Ku-band system is used to transmit all video—internal and external—from the ISS. Live and recorded video are transmitted in high definition and standard definition. High definition has become the preferred format as the available bandwidth from the ISS has increased. Two-way video

## **Astronauts Make the Call . . . From Space!**

The ability to make a telephone call from the ISS is extremely helpful to the crew members, psychologically, by allowing them to feel more connected to home. Calls may be personal—to a spouse or dear friend—or to the flight director to talk privately about an issue. However, this process is not as straightforward as making terrestrial phone calls. In particular, the crew can conduct a call only when the Ku-band satellite link is present. The calls must be initiated by the crew for privacy and security reasons. Receiving a phone call from space is a fun and unique experience. However, cases have occurred where recipients were incredulous about incoming calls from the ISS and would hang up on the caller. Also, as with phone calls on Earth, the wrong number can be dialed, which has happened on occasion. This system is also useful for the ground team. On more than one occasion, the crew was required to fix a problem with the S-band radio link. Because of the ground team's inability to call the crew over the S-band radio link to request a procedure, the crew's timeline was re-uplinked via the Ku-band system with a big banner-type message that instructed the crew to initiate an internet protocol call to Mission Control.

conferencing is supported and used routinely. The Ku-band system was upgraded to support a pair of two-way voice communication channels. Operationally, these channels are called S/G 3 and S/G 4. They augment the S/G 1 and S/G 2 channels in the S-band system. The ISS crew members can use the Ku-band system for email, internet access, and phone calls (i.e., internet protocol calls) to any number on Earth. The biggest use of the Ku-band system are the payloads that conduct scientific experiments on board the ISS. All the scientific data are transmitted to the ground by the Ku-band system.

The forward link of the Ku-band system is used to transmit operational planning data, control experiments, and to remote log-in to the ISS Local Area Network. The

remote log-in process is needed to conduct operations (e.g., controlling Robonaut) and troubleshoot equipment, and to support email, two-way video conferencing, and telephone calls.

The Ku-band system is the communication workhorse of the ISS. Every nation involved in the ISS depends on the system, mainly for their scientific research.

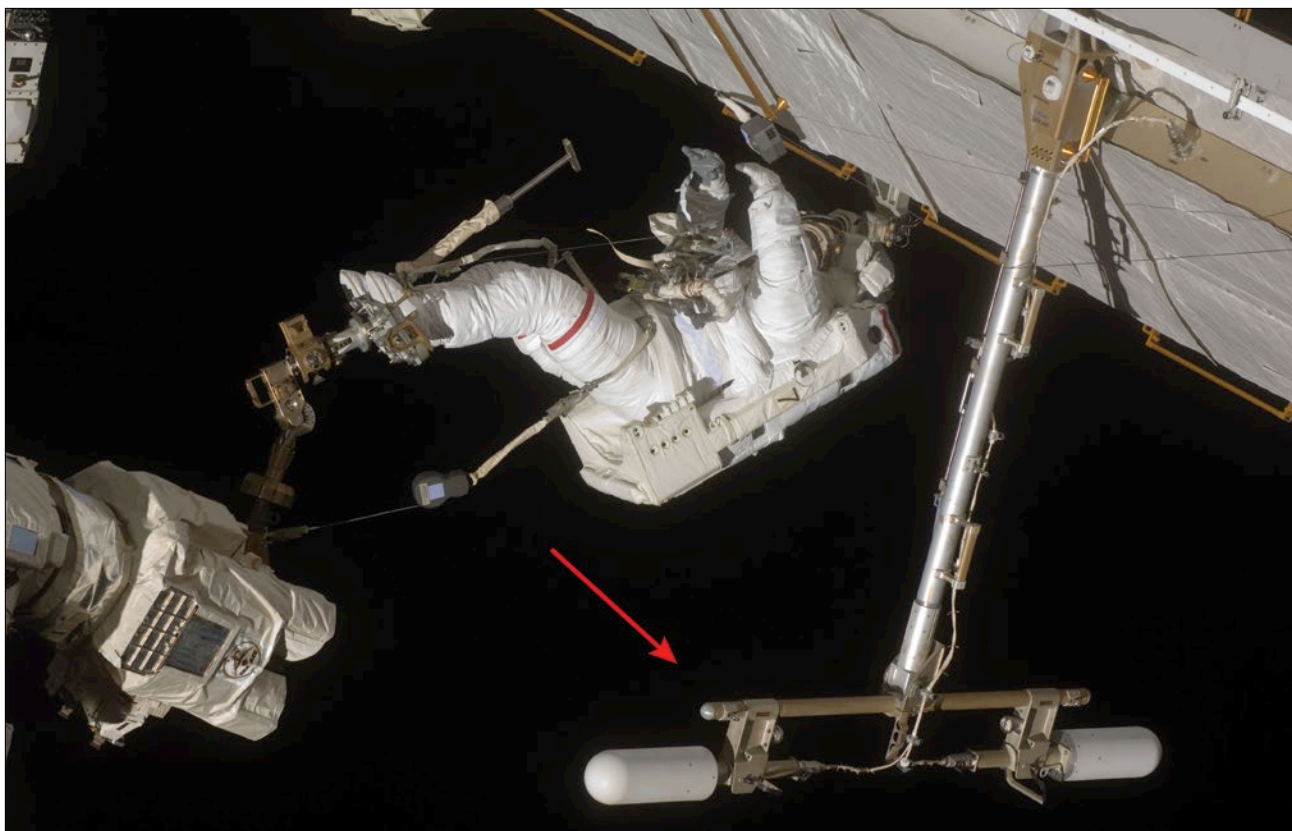
The Ku-band system is highly directional. It must be pointed at the TDRS satellite within 0.5 degrees to transmit the high data rates. The GNC MDM and C&C MDM produce the pointing angles for the Space-to-Ground Antenna gimbals at a rate of once per second. The antenna then uses these angles to initiate a search of the forward link signal that is

being relayed from the ground by the TDRS satellite. Once locked onto the signal, the antenna uses that signal to automatically track the TDRS satellite within the required accuracy.

## Ultra-High Frequency

The ISS is equipped with a bidirectional UHF communication system, as seen in Figure 4.

The UHF systems provides two-way voice communication with the spacewalking astronauts and the ISS. A two-way voice link between the spacewalking astronauts and the flight control team on the ground is established when the audio portion of the UHF system is connected to the S-band system. Data from the astronauts' suit and



**Figure 4.** Mission Specialist Dave Wolf during STS-127/ISS-2 J/A on the P1 truss directly behind the UHF antennae.

biomedical data from the astronauts are transmitted to the ISS on the UHF system and then sent to the ground via the S-band system.

The UHF system is only meant to be used around the vicinity of the ISS. The system cannot communicate directly with UHF stations on the ground because of the way the data are incorporated into the radio signal.

### Wireless External Transceiver Assembly

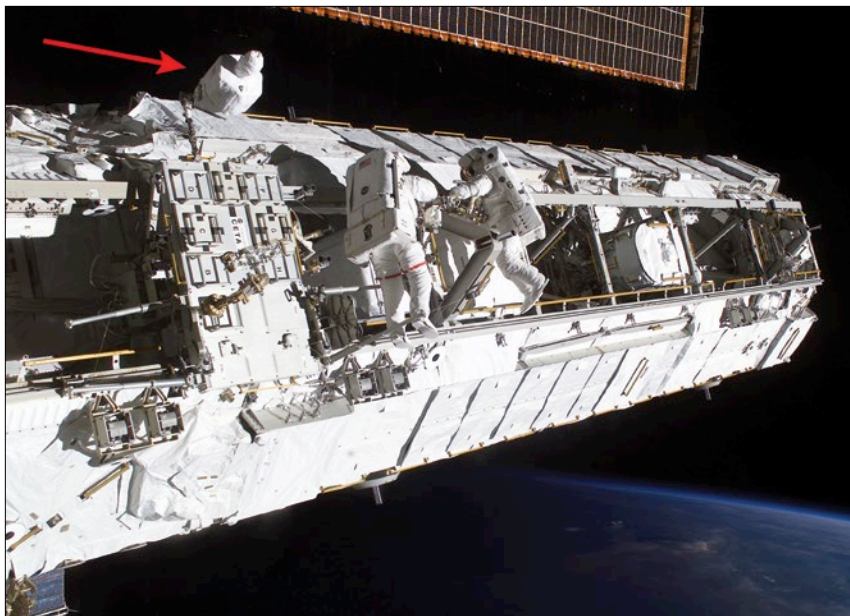
Another radio frequency communication system—the Wireless External Transceiver Assembly—is associated with US spacewalks (Figure 5). The more common name for this system is the helmet cam video. Through a combination of a UHF link and an S-band link, the cameras that are mounted to the spacewalkers' helmets provide real-time video back to the

ISS. This video can be transmitted to the ground via the Ku-band system. The UHF link is used to issue commands to the three cameras that are mounted on the helmet. The S-band link is used to transmit the live video from one camera at a time to antennae mounted on the ISS.

### Ship-to-Ship Communication Systems

All spacecraft that approach the space station communicate directly with the ISS, once in range. Communications between spacecraft is often called “ship-to-ship.” The type of communication system, the capabilities, and the usable range vary from one spacecraft to another even though they are typically in the S-band portion of the spectrum. The Space Shuttle communicated with the space station via a UHF communication system that supported

limited commanding, limited telemetry exchange, and two-way voice between the commanders of the two vehicles. The uncrewed cargo vehicles that resupply the space station (see Chapter 14) also communicate directly with the ISS, when in range. Incoming vehicles receive navigation information from the ISS that may be used to perform a rendezvous using Global Positioning Satellite data for each vehicle. Uncrewed cargo vehicles also accept crew-issued commands over the ship-to-ship communication system (e.g., abort and retreat) and provide telemetry on their key systems back to the ISS for the crew to monitor. These RF ship-to-ship communication systems are typically active only during the approach of the visiting vehicle. After a successful capture or docking, the system is deactivated. The operation of the system is the joint responsibility of Mission Control and the control center associated with the visiting vehicle (see Introduction).



**Figure 5.** Mission Specialists Michael E. Lopez-Alegria (left—red stripes) and John B. Herrington (right—no stripes) perform Starboard Keel Pin operations on the P1 truss during STS-113/ISS-11A. The Wireless External Transceiver Assembly antenna is in view in the upper left (red arrow), above the Crew and Equipment Translation Cart.

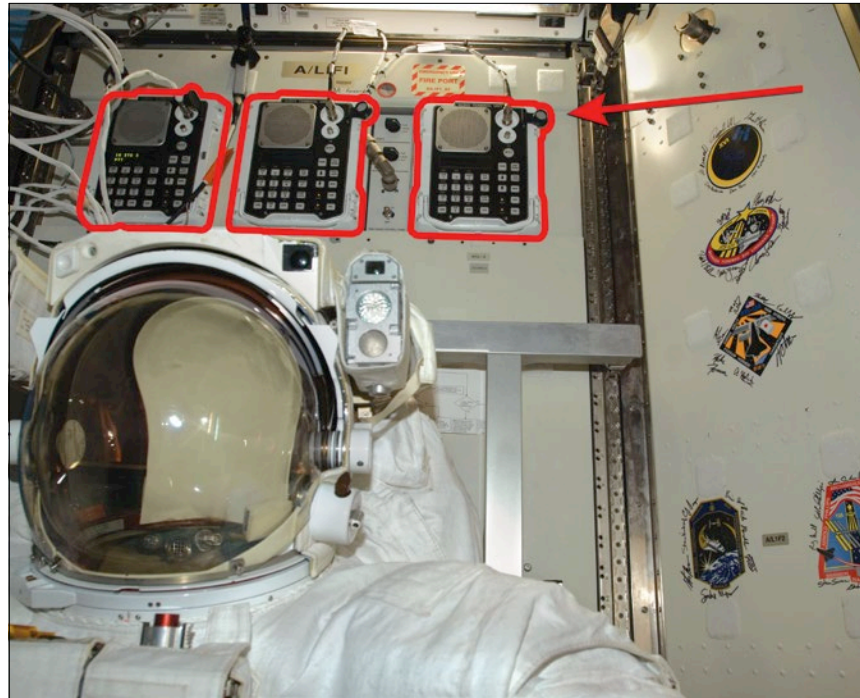
### Baseband Communication Systems

#### Audio

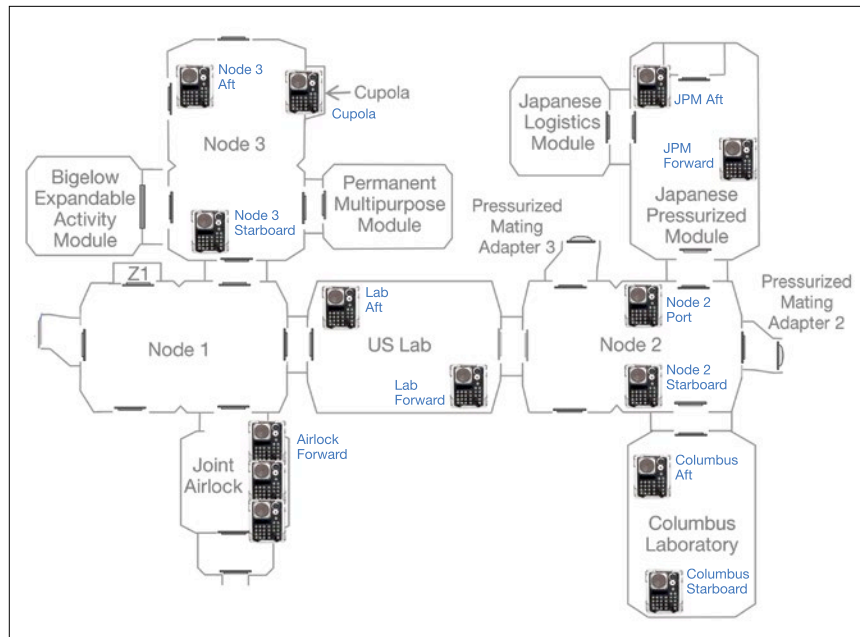
An audio system on board the ISS allows crew members to talk to each other across modules and talk to the control centers on the ground. A key component of the audio system is the Audio Terminal Units (ATUs), shown in Figure 6. The ATU is essentially a complicated intercom system. The microphone converts speech-to-digital signals that the audio hardware then routes to any other communication panel on the ISS. A speaker reverses the digital-to-speech conversion.

Fourteen ATUs are located throughout the United States On-orbit Segment (USOS) (Figure 7). The audio system also connects to the S-band and Ku-band systems to give the crew members access to the space-to-ground voice loops. Three alarm tones (emergency, warning, and caution) signal that something serious has occurred and the crew members are to respond (see Chapter 5). These alarm tones are also annunciated through the audio system.

The audio system is a Time Division Multiple Access digital system. As many as five conference calls can be supported simultaneously with up to 12 ATUs connected to each conference. An ATU can be, and usually is, connected to more than one conference at a time. The astronaut is able to talk to anyone on the ISS or the ground that is tied into that conference by simply pushing a button on the ATU for the appropriate conference call. In a typical operational configuration, the first conference, known as Public Call 1, will include the Russian Segment and is used to talk to all crew members throughout the ISS during an emergency. The Russian Mission Control Center uses Public Call 1 for daily operations with the cosmonauts. The Americans, Europeans, and Japanese use two other conferences, known as Public Calls 2 and 3, for day-to-day systems operations and for payload (science) operations. The fourth conference, known as Public Call 4, usually includes only the USOS modules and is used by American, European, and Japanese control centers for private communications (e.g., when a crew member is conducting a planned, weekly conference with a flight surgeon or family member).



**Figure 6.** Three ATUs (red arrow) are located at the top, above the spacesuit, in the airlock. During preparation for a spacewalk, the suited crew members can plug into these units to communicate with each other and the rest of the crew or to the ground without using the battery-powered UHF system in the suit. Or, a crew member who is assisting the spacewalkers can use the ATU as a normal intercom.



**Figure 7.** Location of the ATUs throughout the USOS. In addition to providing communication between crew and ground, the ATUs provide caution and warning alarms.

## Video

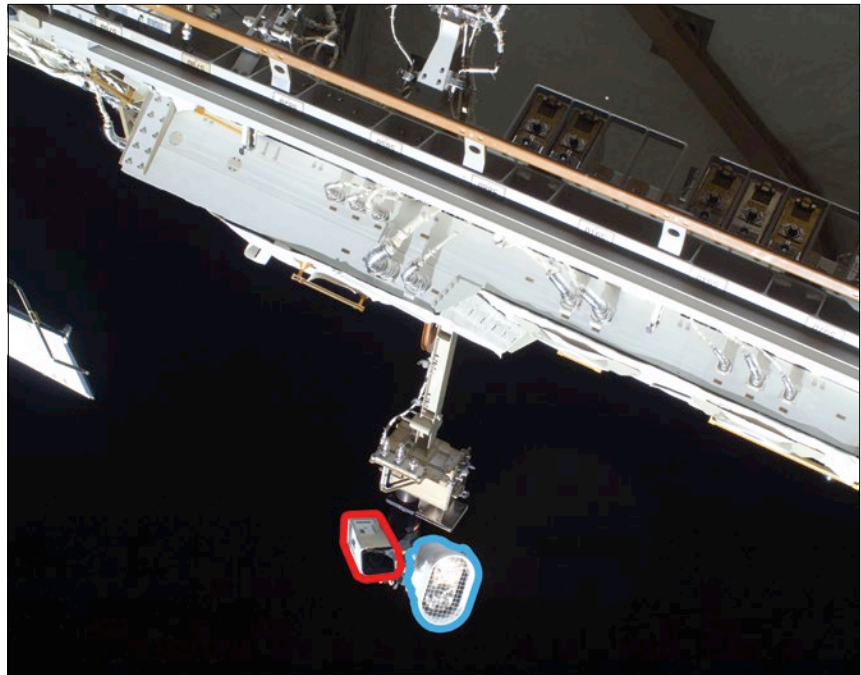
The video system on board the ISS generates and distributes high-definition and standard-definition video. As with audio, video signals can be routed from a variety of sources and directed to an assortment of destinations—whether it be to a computer monitor for the crew or to the ground. Standard definition cameras that are mounted externally are known as the External Television Camera Group (Figure 8). This group consists of the camera that can be panned, tilted, and zoomed, a light that moves with the camera, and a controller. These cameras operate continuously on the ISS and provide video of spacewalking astronauts, views of visiting vehicles, or views of the outside of the space station for the ground controllers to monitor (see Chapter 17).

The crew on board the ISS and by the flight control teams and engineering support teams around the world use the video system to monitor spacewalks, robotics operations, and arrival and departure of visiting vehicles, as well as for inspections of the ISS. Recall that there are very few windows to actually allow the crew to see outside. Live video of the astronauts can be useful for the ground team to monitor activities and assist the astronauts in their work. When the ISS bandwidth allows (i.e., not all in use by payloads or telemetry), one video feed from the ISS is streamed live on the internet. Occasionally the external cameras are used to track hurricanes and typhoons since the ISS provides a unique, real-time vantage of such situations. The video system is a key part in conducting media outreach-type events on board the ISS to

help educate the public about life on the ISS. Often, the astronauts participating in the live event serve as their own camera crew. They will set up the camera in advance. Then, the flight control team will configure the video and Ku-band system to bring the view from the camera to the ground where the NASA Public Affairs Office distributes the video to the client. Figure 9 shows Expedition 31 flight engineer and European Space Agency astronaut Andre Kuipers setting up a camera in preparation for a Public Affairs Office event in the US Laboratory. Two other cameras are visible in addition to the one Kuipers is setting up. Over time, the camcorders on the ISS were replaced with more recent models.

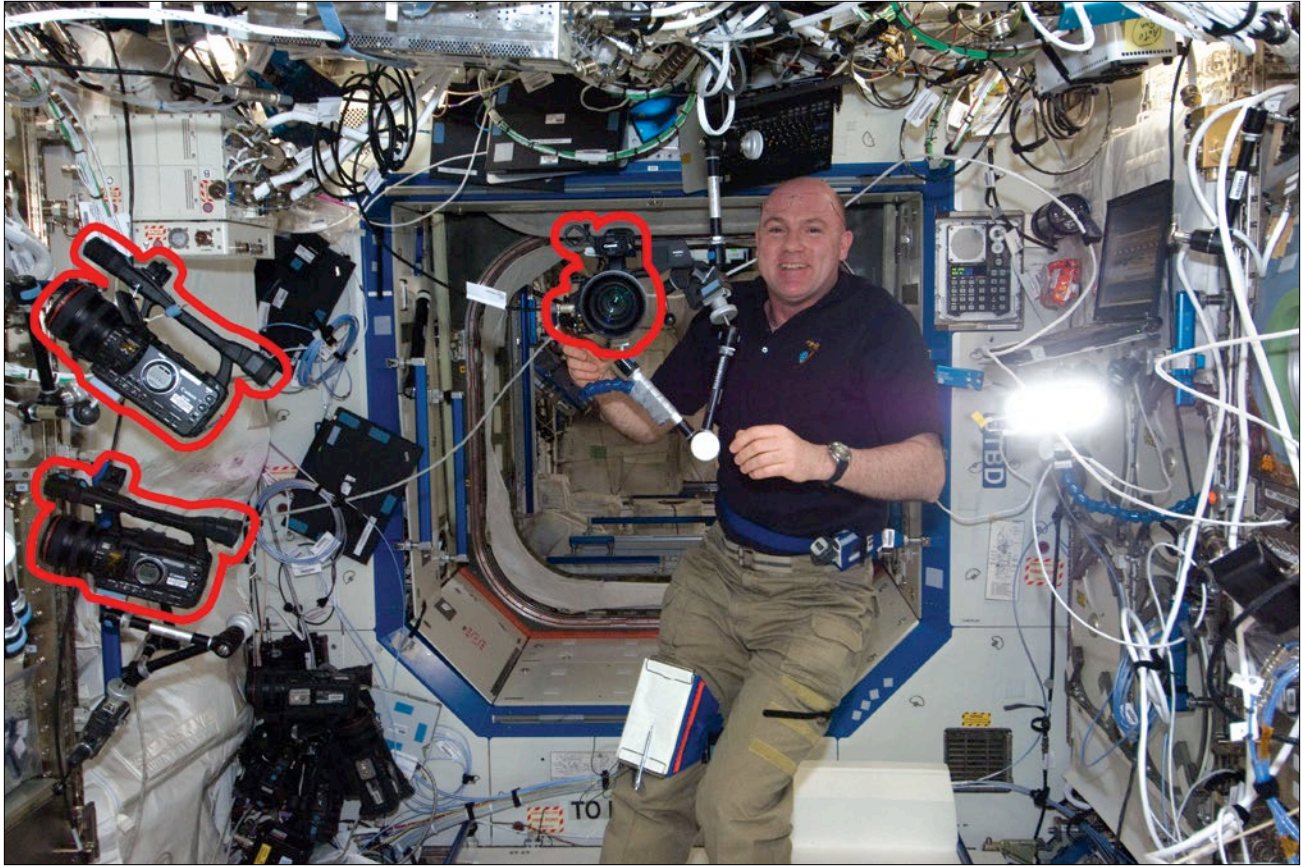
The video from these cameras and the video from the Wireless External Transceiver Assemblies go

external to internal by way of one of three external video switching units. Once internal to the ISS, the video is further distributed by one of four video switching units. High-definition video recorders are typically distributed throughout the USOS modules inside the ISS. The video from these recorders is also distributed throughout the ISS and are connected to the Ku-band system, allowing video to be downlinked to the ground. The video units are also connected to the Robotic Workstation monitors in the Cupola and the US Laboratory, thereby allowing the crew to view the live video from the External Television Camera Groups or from the Mobile Service System (see Chapter 15). Usually, the flight controllers will configure the video system when it is needed, leaving the crew to only power up and position internal cameras.



**Figure 8.** View of the S1 truss segment External Television Camera Group. The white oval is the light attached to the camera (tan rectangular box directly to the left of the light). If there is nothing critical to watch at the ISS, the flight controllers will point the cameras at the Earth to allow the team to enjoy the view from above in the control center.





**Figure 9.** In 2012, Expedition 31 flight engineer and European Space Agency astronaut Andre Kuipers works with a video camera while preparing for a Public Affairs Office event in the Destiny US Laboratory.

Managing the video system is a complicated job performed by the Communication Rf On-board Network Utilization Specialist. The video management needs to be planned in advance and executed on time because of the dozens of video sources on board the ISS, Ku-band return link bandwidth limitations, time constraints, and input and output constraints on the video switches. In addition, a number of payloads use video, recorded and live, to observe experiments and document the results. The daily coordination spans multiple control centers around the world.

## Conclusion

Since the beginning of the Space Age, video and audio communication systems have been referred to as the eyes and ears of a spacecraft. The communication system of a spacecraft has always been vital to a mission, whether for video of an astronaut saying, “Roger, zero-g and I feel fine,” from the moon, or video of plants or other experiments on the ISS. In addition to bringing the cosmos to Earth, the ground uses communication systems to support the astronauts by ensuring they complete their missions safely and

effectively. The ISS has a number of different communication systems that are used for highly specific functions. Audio communication between crew members on the large space station, as well as the ground, allows for timely, efficient operations. Video can be used to provide information about life on board the space station or to record data. Due to the critical nature of communication, the systems are designed with a great deal of robustness and redundancy. To help ensure a smooth operation, the flight control team is just a quick call away.



## Chapter 14 Day in the Life:

Vital Visiting Vehicles—  
Keeping the  
Remote Outpost  
Crewed and Operating



Expedition 45 astronauts and cosmonauts gather to watch the launch of the Orbital ATK Cygnus resupply spacecraft atop of the United Launch Alliance Atlas V rocket from Cape Canaveral, Florida on December 6, 2015.

## Purpose and Importance of Visiting Vehicles

***On Earth, a person's typical week might consist of a trip to the grocery store, several trips to the local home improvement store, taking out the trash and recyclables, and doing a few loads of laundry.*** If something is broken in the home, a replacement part is ordered and the homeowner must wait for a delivery. Or, he or she might need to schedule a professional to make the repair. Homeowners probably do not think about the water supply. They definitely do not worry about the supply of oxygen needed

to breathe or the removal of carbon dioxide that is expelled from the human body.

The International Space Station (ISS) is a unique, world-class orbiting laboratory. It is also home to astronauts and cosmonauts. The logistics of keeping such a home running are complicated. In space, there are no grocery stores or home improvements stores. The “trash truck” only comes around every few months. Washers and dryers for clothing do not exist, and access to clean attire can take months. Much of the breathable air and drinkable water must be delivered. When supplies

(e.g., bathroom tissue) are low, crew members cannot tap a few keys on the computer and wait for resupplies to arrive at the door. They call Mission Control and place their order, and then they wait.

Moving astronauts and cosmonauts, science experiments, food, water, air, spare parts, and other supplies to and from the ISS is a highly choreographed international operation that must be executed with near perfection, every time (see Chapter 1). Such an effort requires more than one spacecraft. This was never more evident than in an 8-month span between October 2014

and June 2015 when three different resupply missions were lost during or shortly after launch. Three different rockets from three different companies experienced three different failures. According to statistics, this scenario was supposed to be nearly impossible. Yet, it happened. Operations on board the ISS continued despite the lack of resupply.

So, exactly what does it take to keep the ISS resupplied? It starts with a procession of vehicles from around the world that visit the ISS. This chapter will discuss this lineup, including the unique way the vehicles are attached to the space station and how heavily they rely on the robotic system. The critical role of the crew, how a vehicle controlled by another government or a private US company is safely integrated into the operations of the ISS, and how their flight control teams train and interact with the NASA flight control team in Houston, Texas, are also presented. Details for the Russian cargo vehicle, Progress, are not discussed here.

## Lineup of Visiting Vehicles

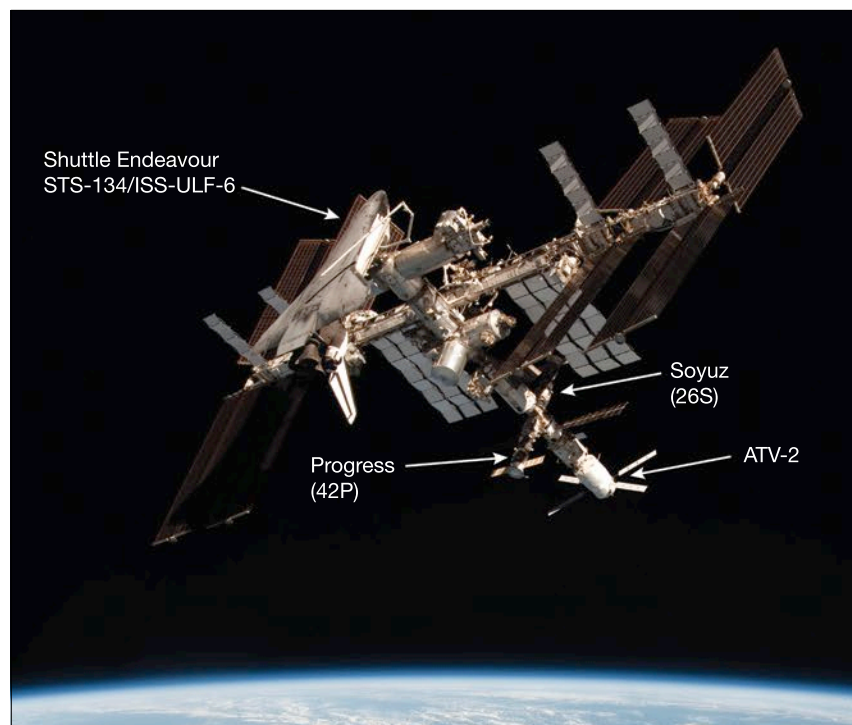
**Space Shuttle** (retired)—The NASA Space Shuttle was launched from Kennedy Space Center in Cape Canaveral, Florida, and controlled from Mission Control Center-Houston (MCC-H). It carried crew of up to seven and cargo to and from the ISS. The shuttle could deliver approximately 19,000 kg (42,000 lbs) of cargo, usually in the form of modules or elements in the external cargo bay, but it could also transport dry and wet cargo. Dry cargo consists of hardware, food, and other non-

wet consumables whereas wet cargo generally refers to water, nitrogen, oxygen, or air. The shuttle docked to the United States On-orbit Segment (USOS) of the ISS. As happens with all the visiting vehicles, dry cargo is always accessed from the pressurized part of the vehicle in a shirt-sleeve environment. Figure 1 shows the Space Shuttle docked to the ISS, as well as the next several vehicles, in what was termed the “family portrait.”

**Soyuz**—The Russian Soyuz Spacecraft launches from the Baikonur Cosmodrome in Kazakhstan, and is controlled from the Mission Control Center-Moscow (MCC-M) in Korolev, Russia. It carries a crew of three and a limited amount of cargo to and from the ISS. The Soyuz docks to one of several ports on the Russian Segment (RS) of the ISS.

**Progress**—The Russian Progress Spacecraft launches from the Baikonur Cosmodrome in Kazakhstan, and is controlled from the MCC-M in Korolev, Russia. It carries cargo to the ISS and removes trash from the ISS via destructive reentry. The Progress can transport approximately 2,600 kg (5,732 lbs) of dry and wet cargo to the ISS and docks to one of several ports on the ROS. Unique among the current visiting vehicles, the Progress also transports propellant for the re-boost and refueling of the station.

**Automated Transfer Vehicle (ATV)** (retired)—During five missions between 2008 and 2014, the European Space Agency (ESA) launched the ATV from the Centre Spatial Guyana near Kourou, French Guiana, and controlled it from the ATV Control



**Figure 1.** This image was taken in May 2011 by Expedition 27 crew member Paolo Nespoli from the Soyuz (25S) following its undocking to return the Expedition 27 crew to Earth. These are the first images of a Space Shuttle docked to the ISS, as taken from another crewed spacecraft.

Center in Toulouse, France. Each ATV carried cargo to the ISS and disposed of trash from the ISS via destructive reentry. The ATV was able to deliver 8,000 kg (17,637 lbs) of supplies, including dry and wet cargo with propellant for the re-boost and refueling of the station, and docked to the aft docking port of the RS.

### **H-II Transfer Vehicle (HTV)**

**Kounotori** (White Stork)—Japan launches the HTV from the Tanegashima Space Center in Tanegashima, Japan, and controls it from the HTV Control Center in Tsukuba, Japan. The HTV carries cargo to the ISS and disposes of trash from the ISS via destructive reentry. The HTV is captured by the Space Station Remote Manipulator System (SSRMS) and is then berthed to the USOS, as shown in Figure 2. Each HTV can deliver approximately 7,600 kilograms (16,800 lbs) of cargo, including external cargo transfer capability.

**Dragon**—Developed by the commercial company Space Exploration Technologies Corporation (SpaceX), Dragon launches from Cape Canaveral, Florida, and is controlled from the SpaceX Mission Control Center in Hawthorne, California. Dragon carries cargo to the ISS and returns cargo and science via splashdown in the Pacific Ocean off the coast of California. As with HTV, Dragon is captured by the SSRMS and berthed to the USOS, as shown in Figure 3. Dragon can transport approximately 5,400 kg (12,000 lbs) of cargo, including some items externally in its exposed “trunk.”



**Figure 2.** The Japan Aerospace Exploration Agency Kounotori HTV-5 is seen berthed to the ISS (vertical, left side of image). The external CALometric Electron Telescope experiment, which will search for signatures of dark matter, is seen being extracted from the unpressurized section by the station's robotic arm, Canadarm2. An aurora over the Earth limb is visible in the background. Photo is from August 25, 2015.



**Figure 3.** View of the berthed SpaceX Dragon Commercial Resupply Services-3 spacecraft on April 26, 2014, Canadarm2 SSRMS, and portions of the forward ISS in front of an orbital dawn.



**Figure 4.** The Orbital ATK Cygnus spacecraft about to be captured by the Canadarm2 on March 26, 2016, before being berthed to the nadir port of the Node 1 module of the ISS, as photographed by an Expedition 47 crew member. The Earth can be seen in the background.

**Cygnus**—Also developed by a commercial company, Orbital ATK, the Cygnus can launch from the Mid-Atlantic Regional Spaceport on Wallops Island, Virginia, or from Cape Canaveral, Florida. The mission is controlled by a team at Mission Control Center-Dulles located in Dulles, Virginia. Cygnus carries cargo to the ISS and disposes of trash from the ISS via destructive reentry. As with the HTV, the Cygnus is also captured by the SSRMS and berthed to the USOS (Figure 4). Cygnus can deliver up to about 3,600 kg (7,940 lbs) of cargo to the ISS.

## Preparation for the Arrival of an H-II Transfer Vehicle, Dragon, or Cygnus Visiting Vehicle

### Scheduling

As described in Chapter 1, the flight control team works with ISS Program personnel, including the international partners, to meticulously plan the rotation of crew members, delivery of new science experiments, return of completed experiments, and resupplies for the ISS. Launch schedules around the world need to be negotiated. This, in itself, can be extremely complicated. Each company or government launches other payloads; therefore, delays on one vehicle, due to weather

or technical issues, can impact other missions to the ISS. Careful coordination is also required to manage the available ports for berthing the vehicles. The only two berthing ports are located on the nadir, or bottom, side of the ISS. Cargo preparation and delivery schedules need to be established and often adjusted when equipment unexpectedly fails or priorities change. In some cases, the orbit of the ISS needs to be adjusted to accommodate the arrival of the visiting vehicle. Physics determines how quickly a spacecraft can get to the ISS, and must be factored into the power and fuel with which the vehicle has to perform the rendezvous. The number of constraints that need to be simultaneously satisfied for even a single mission proves to be a challenge almost every time. Some highly unusual constraints have impacted the scheduling of launches. For example, during the Japanese fishing season off the coast of Tanegashima, large numbers of fishing vessels are situated off the waters of the launch site, which would put people at risk if a rocket exploded. Another constraint was the estimated pressure in the off-nominal case of an explosion of the vehicle near the Mid-Atlantic Regional Spaceport in Virginia. Yet another was the G8 summit in Arkalyk, Kazakhstan, and the associated air space restrictions over Kazakhstan during the arrival of all the Heads of State. This situation prohibited the Russian search-and-rescue aircraft from conducting the Soyuz recovery mission on the original date. Other constraints have included the sea state

## “Piece by Piece; Step by Step”

*Jeff Williams, STS-101, ISS Expeditions 13, 21, 22, 47, 48*

Among the most impressive—and sometimes overlooked—aspects of the history of the ISS assembly and ongoing operations are the visiting vehicles necessary to build and sustain the space station. Napoleon Bonaparte is credited with the quote, “an army marches on its stomach,” emphasizing the criticality of logistics to ensure mission success of a deployed military. The same is true of the space station and her continuously deployed crew. As of mid 2017, 178 rocket launches were dedicated to building, manning, and maintaining the ISS.

Food, of course, is just one element of the vast logistics train necessary in keeping the ISS and its crew going strong over the many years away from the planet. My first visit to the orbital outpost on a Space Shuttle crew in 2000 was, in part, dedicated to stockpiling the supplies and equipment necessary to prepare for the arrival of Expedition 1. Over the years since, during long-duration expeditions to the growing complex, I experienced visits by four additional Space Shuttles and stays of seven Soyuz spacecraft besides my own three, and I watched eight Progress, one HTV, one Cygnus, and two Dragon spacecraft come and go. Food—including fresh fruits and vegetables and, occasionally, even ice cream—was present on every vehicle. So was clothing, general supplies, repair parts and tools, large and small elements of the growing complex, science and research experiments, new technology demonstrations, and even

“cards and letters” from home. Several of the shuttles and Russian rockets delivered major components of the ISS, including module and truss elements. Most significantly, the Space Shuttles and Soyuz spacecraft enabled the coming and going of crewmates.

Spaceflight is inherently hard, and access to space from Earth and the return to Earth are particularly hard phases. That is what makes the ISS visiting vehicle story so impressive. The loss of several supply ships during the launch and ascent phase gives testimony to the particular challenge of sustaining the orbital outpost. The loss of our friends on the Space Shuttle Columbia, which grounded the fleet during the ISS assembly, makes it a particularly human challenge.

What we have learned from the critical role of visiting vehicles and the logistics train supporting the ISS will be an essential enabler for future exploration beyond Earth orbit. We will, of course, improve regenerative efficiencies for things such as water and atmosphere, and we will even find ways to draw from natural resources at the location of future destinations. However, there will always be a dependency on resources and consumables from Earth, especially those required for life support. Regardless of future ends in space exploration, launching and returning vehicles will always be among the required means to accomplish the goals and objectives. As with the space station, that will be piece by piece, step by step, by way of visiting vehicles.

in the Pacific Ocean off the coast of California so that a vehicle could land safely and be recovered, the position of the sun relative to the ISS orbit (known as the beta angle) due to the impact of lighting on key sensors on a spacecraft, and the failure of an external pump on the ISS that took out cooling to half of the space station—including the equipment

needed for safely berthing a vehicle. Because of the number of constraints, it is common for the dates of a visiting vehicle mission to change several times. Operationally, this can mean planning the mission multiple times prior to execution. Once the international community sets a date for a mission, the preparations begin.

### ***Flight Controller Training***

A flight-specific team of controllers will be assigned to each visiting vehicle mission no later than approximately 6 to 8 months ahead of the scheduled event. A team of flight controllers, led by a flight director, will be at MCC-H, and a team of flight controllers will be at the home



control center of the visiting vehicle. These teams will spend months preparing procedures and flight rules to govern the real-time execution of the mission. The team will also simulate the operations multiple times to ensure the procedures and rules are correct, the timing and communication between the control centers is perfect, and the ground equipment that allows the control centers to share data and voice communication is operational (see Chapter 10). The simulations, conducted jointly between NASA and the home control center for the visiting vehicle, generally occur between launch minus 6 weeks and launch minus 2 weeks.

When the approaching visiting vehicle enters the real-time phase of the mission known as Joint Operations, the mission authority transfers from the home control center of the vehicle to MCC-H, except in the case of Russian vehicles when the MCC-M is in charge. The home control center retains vehicle authority and is responsible for configuration and performance of the vehicle. NASA is responsible for the overall safety of the ISS crew, the safety of the ISS, and the mission objectives. Within Joint Operations, all decisions to proceed to the next phase of the mission (known as “go/no go” decisions) are made by the flight director in MCC-H after consultation with the mission director at the home control center. These roles and responsibilities are stressed during the training so that decisions can be made accurately and expeditiously during the real-time execution of the mission.

### ***Crew Training***

The crew on board the ISS has a critical role in the execution of a visiting vehicle mission. The crew will monitor the incoming vehicle, starting at a range of approximately 1000 m (3281 ft) relative to the ISS. The crew is given specific parameters to monitor and actions to take if the vehicle violates preset criteria. The crew monitors the vehicle range relative to the ISS, the range rate or speed, and the position of the vehicle relative to the space station. If precisely defined criteria using these parameters, previously worked out between the two flight control teams, are violated, the crew can issue a command to the incoming vehicle over the ship-to-ship link (see Chapter 13) to have it hold its current position, retreat to a preset previous position, or perform an abort and fly away from the ISS. This monitoring is critical to prevent a collision between the visiting vehicle and the ISS. For example, each visiting vehicle will move toward the ISS within the approach corridor, which is a cone with its apex centered on the destination point of the visiting vehicle. The ISS crew will issue a command for the visiting vehicle to abort its rendezvous and move away from the station if the spacecraft goes outside of this corridor, thus indicating that the control system is not working properly and the ISS is at risk of a collision if the trajectory worsens.

The home control center of the vehicle is responsible for commanding the vehicle to advance toward the ISS after receiving the appropriate approval or “go” from the flight director at MCC-H. Once the incoming berthing vehicle reaches a predetermined position—

about 11 m (36 ft) underneath the ISS—it will hold its position relative to the space station. At this point, the visiting vehicle and the ISS are flying in formation. The crew will use the SSRMS to grab the visiting vehicle. This is known as the capture operation. As they do with a module, the astronauts will maneuver the robotic arm end effector and capture a grapple pin on the hovering vehicle. The capture needs to be performed precisely so as to avoid knocking the vehicle and thereby causing it to spin and move uncontrolled in close vicinity of the ISS. Once captured by the arm, the vehicle automatically goes to what is known as free drift, which means it is no longer firing any of its thrusters. This allows the SSRMS to maneuver the vehicle to its berthing port without damaging it through an unexpected push or pull by a thruster. See also Chapter 15.

The crew procedures, displays, data, and training need to be near perfect because of the close interaction between the crew and the flight control teams on the ground and the tight timeline choreography. Crew members are trained on the ground before they begin their mission on board the ISS. About a week prior to the arrival of the visiting vehicle, crew members conduct their refresher on-board training as it likely has been many months since they received training on the ground. The crew uses a robotic arm computer-based simulator to practice moving the SSRMS in and capturing the visiting vehicle. In the days leading up to the arrival of the vehicle, the crew will practice the capture operation over and over again on a laptop

computer simulator, which includes hand controllers to replicate the grappling with the robotics system in preparation for the real operation. The crew members will also review their monitor procedures, criteria to take action, and the actions. The crew and the flight controller teams will conduct a conference led by the flight director about 1 to 2 days prior to the arrival of the vehicle to make sure everyone is ready for the operation.

### ***Cargo Delivery and Loading***

As the flight control teams prepare the mission, the cargo teams finalize the list of cargo to fly on the visiting vehicle. The supplies on the ISS, including spare or replacement parts, are meticulously tracked and resupply schedules are set and reset on a continual basis. Time is also allocated for carefully packing the cargo on the spacecraft. Not only does it have to be meticulously

packed to withstand the forces of the launch, but the mass has to be precisely balanced to ensure the vehicle flies correctly. Last-minute issues on board the ISS that require unplanned resupplies or new hardware are balanced against the mission schedule to determine what can be accommodated. Consumables such as food, water, and oxygen have to be very carefully managed. Not only are enough supplies needed,

## **Are we there yet?**

As noted in Chapter 7, the ISS orbits the Earth at an altitude of about 410 km (255 miles) above the surface. About a dozen vehicles from various countries and organizations visit the ISS every year.

When describing the physics that govern their rendezvous with the ISS, two principles should be considered—principles that are too complicated to go into here. First, Newton’s Law of Gravity says that gravity pulls on objects in lower orbits with more strength than it pulls on objects in higher orbits. Second, Kepler’s Laws of Planetary Motion say, in part, that objects traveling in lower orbits go around the Earth faster than objects in higher orbits.

In planning orbital rendezvous, both principles need to be considered simultaneously. In short, the process is similar to the case of a police officer who is sitting at the side of the road, looking for speeders. The officer cannot leave his or her observation spot (i.e. “launch”) until the speeding car passes. Once this happens, the officer has to catch up—first accelerating to higher speeds to close the gap and then gradually slowing to match the speed of the car he or she is pursuing. If the officer doesn’t slow down and match the speed of the other car, he or she risks hitting it and causing damage. If the officer lets the car get too far ahead before pursuing, he or she may not have enough fuel to catch the speeder. If a cylinder on the car is misfiring or if the weather is bad, the officer will have to make additional driving adjustments.

In the case of the ISS, the visiting spacecraft will launch when the ISS flies overhead. The vehicles are uncrewed and rendezvous with the ISS autonomously with guidance from the control center. During the mission, the Visiting Vehicle Officer monitors the maneuvers or burns of the spacecraft as it climbs to the orbit of the ISS, and then matches the speed for a capture by the robotic arm or gentle docking. The trajectory is updated as things change during rendezvous, which can happen if a thruster does not quite burn as expected or if atmospheric drag is different than expected due to variations in the sun—among a multitude of other reasons. Small burns may be added to the mission to compensate for these issues. To complicate matters, the rendezvous has to be timed precisely so that the sun does not blind cameras or crew members. This process can take as few as 6 to 8 hours but typically takes about 2 to 3 days.

When the vehicle is in close proximity of the ISS, even a few meters away, it is technically in a different orbit and therefore will move slightly differently than will the ISS. At this point, it is a little like keeping a balloon off the floor. Gravity will try to pull the balloon back to the Earth, but small upward taps with the hand will keep it in the air. Newton told us that the Earth will try to pull the visiting vehicle down faster than the ISS; however, thrusters are used to tweak the motion to keep it in close proximity. The visiting vehicle officers watch this dance very closely to ensure a successful rendezvous while the flight director ensures the ISS is ready for the new spacecraft.

extra materials have to be sent to the ISS to protect for the case when another cargo vehicle—or three, as mentioned above—cannot make it to the ISS. Once the manifest is finalized, the items are packaged and delivered to the visiting vehicle company for packing into the vehicle. The delivery of the cargo is usually staged. Items that are ready early are sent first. Usually, a late load of items accommodates last-minute changes to the manifest, or there may be science experiments that have strict timing constraints between launch and arrival on the ISS. Once the cargo has been loaded, the spacecraft has been declared ready, and the rocket has been declared ready, it is time to launch.

### Day of Arrival

After a successful launch and orbit insertion, the visiting vehicle will spend 2 to 3 days catching up to the ISS. This is referred to as phasing. During this time, the home control center of the vehicle is in charge of the mission. The flight control team at the home control center (Figure 5) monitors the performance of the spacecraft and performs checkouts of the systems that will be used for the rendezvous with the ISS.

The ISS Joint Operations commence as soon as the vehicle reaches approximately 35 km (22 miles) behind and 4 km (2.5 miles) below. MCC-H has mission authority from this point, and until the vehicle completes its mission and departs the ISS. Up to this point, the flight-specific team in MCC-H has monitored the progress and performance of the vehicle, reviewed data, and stayed in communication

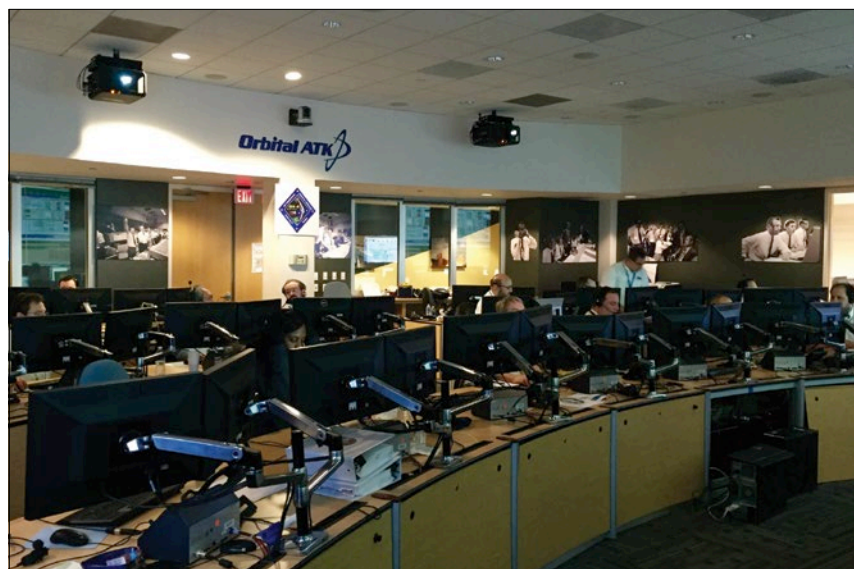
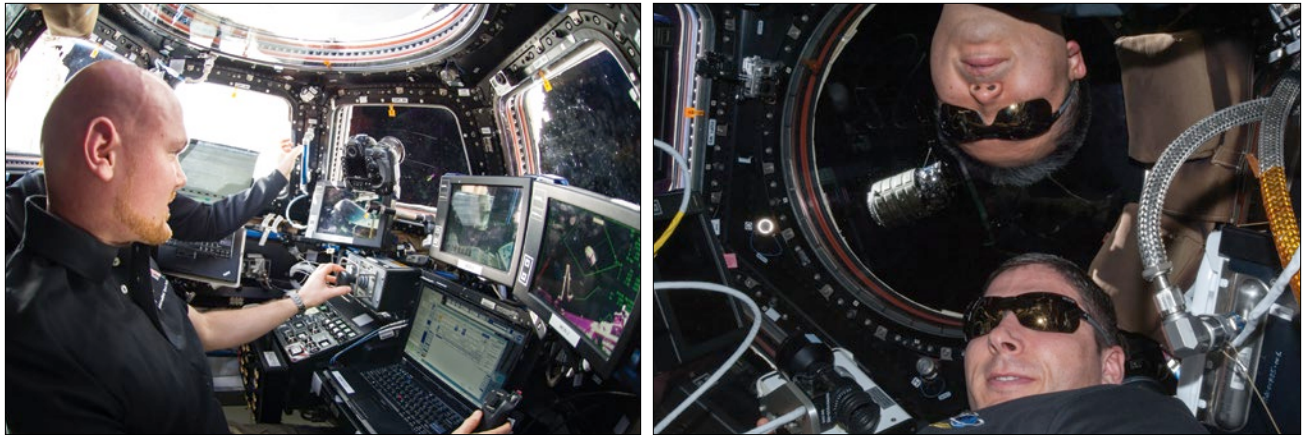


Photo courtesy of Ken Peek (Orbital ATK) used with permission by Orbital ATK

**Figure 5.** (Top) The flight control team supports a Dragon mission from the SpaceX Mission Control Center in Hawthorne, California. Photo from Space Corporation, which has waived all copyright and related or neighboring rights to this work. (Bottom) Image of the Orbital ATK Mission Control Center in Dulles, Virginia.

with the team at the home control center of the vehicle. Joint Operations begins while the crew members are still asleep since the capturing and berthing process can take a significant portion of their day. During Joint Operations, the

vehicle continues to move closer to the ISS and starts orienting its trajectory relative to that of the ISS. As operations progress into the start of the crew day, crew members on the ISS begin preparing for their monitoring role and the capture.



**Figure 6.** (Left) Expedition 41 crew member Alexander Gerst (ESA) as an operator controlling the SSRMS from the Cupola Workstation during the 4th SpaceX mission on September 23, 2014. The Dragon vehicle can be seen in the far right monitor in the image as it approaches the ISS. Astronaut Reid Wiseman floats behind Gerst and performs camera operations. (Right) Japan Aerospace Exploration Agency astronaut Koichi Wakata (top) and NASA astronaut Mike Hopkins, both Expedition 38 flight engineers and both wearing sunglasses, pose for a photo in the Cupola module while waiting for the Orbital-1 Cygnus arrival (in background) on January 12, 2014. The visiting vehicles, which have built-in hold points during their approach, will inch slowly toward the ISS while the flight control teams on the ground assess the performance of each spacecraft and its readiness to proceed closer. Photo was taken during Expedition 38.

At a range of approximately 1000 m (3281 ft), the crew on board the ISS starts looking for the incoming visiting vehicle. Two crew members are situated in the Cupola module, looking down toward Earth. This is where they will conduct the monitoring and the capture operations, as shown in Figure 6. A backup work location is set up and ready in the US Laboratory Module in the event of a failure with the equipment setup inside the Cupola (see Chapter 15).

As the crew monitors the approach of the visiting vehicle, the flight control teams on the ground review the performance data, assess the “go/no go” flight rules, and configure the systems both on the incoming spacecraft and on the ISS to facilitate a safe approach. The Joint Operations become more time critical and riskier as the vehicle gets closer to the ISS. The criteria for proceeding are tighter. When the vehicle successfully

arrives at the capture point, SSRMS operations commence (Figure 7).

To perform this complicated task of monitoring an approaching vehicle, capturing it, and then berthing, the astronauts rely heavily on the robotic systems of the station—especially the Robotic Workstation. External cameras provide critical views with additional graphics overlaid on the image. Those graphics, or overlays, are essentially a heads-up display for



**Figure 7.** (Left) The robotic arm moves toward the unpiloted Japanese Kounotori HTV-4 as it approaches the ISS on August 9, 2013. The HTV-4 is delivering 3,600 kg (7936 lbs) of science experiments, equipment, and supplies to the orbiting complex. (Middle) Using the ISS robotic arm, seen at the right of the picture, NASA Flight Engineer Kjell Lindgren prepares to capture the Orbital ATK Cygnus cargo vehicle on December 9, 2015. The space station crew and the robotics officer in MCC-H will position Cygnus for installation to the orbiting laboratory’s Earth-facing port of the Node-1 module. (Right) The SpaceX Dragon Commercial Resupply Services-3 spacecraft approaches the ISS for rendezvous and grapple during Expedition 39 on April 20, 2014.

the crew, providing such things as joint angles, position and orientation, visiting vehicle approach data (e.g., range and speed), and caution and warning statuses. An example of this is shown in Figure 8.

Under the direction of MCC-H, the crew captures the vehicle using the SSRMS. After a point shortly following the capture, the crew turns over the SSRMS operations to MCC-H. Flight controllers in MCC-H will maneuver the SSRMS and grappled vehicle to the assigned port—Node 1 or Node 2—and position the vehicle for berthing operations (Figure 9).

The rendezvous, capture, and berthing operations, which take a number of hours, are conducted within a single crew day. The flight control team needs to stay on schedule to ensure the visiting vehicle is not stuck on the end of the SSRMS during the crew sleep period. The following day—and, in some instances, the same day—the crew will ingress the newly arrived visiting vehicle. Sometimes, a crew care package has been conveniently stowed where crew members have quick and relatively easy access. The care packages will contain some of the crew members' favorites things. A popular care package item is fresh fruit. Sometimes, notes are included from the flight control team back in Houston, wishing the crew well on the rest of the mission. Crew members will spend anywhere from 1 to several months unloading the cargo and stowing it on the ISS. As they unload the new cargo, they will also start filling the vehicle with



**Figure 8.** An example of using graphics overlay to capture a visiting vehicle—in this case, the first SpaceX Dragon spacecraft to the ISS. This picture shows one of the Robotic Workstation monitors during capture operations for the Dragon vehicle during Expedition 31 (May 25, 2012). The view of the ISS with the robotic arm and the incoming Dragon vehicle are provided by a camera mounted on the truss of the space station. The green lines, numbers, and letters define such things as a safe location for the spacecraft (e.g., the large green rectangle near top center) and the location where the vehicle is expected to be, as indicated by the green outline of the Dragon. These graphics are then overlaid on the video and shown to the crew member who is operating the arm. These overlays provide the crew member with real-time data about the Dragon, such as position and orientation, as well as outlining an imaginary approach corridor that the Dragon needs to maintain as it approaches the space station. Using overlays in this fashion allows the crew member to maintain situational awareness of the incoming vehicle without having to take his or her eyes off of the video showing the actual approaching vehicle.



**Figure 9.** Flight controllers led by Flight Director Brian T. Smith (standing left of center in the third row from the front), supported the orbital work in the space station flight control room in Johnson Space Center's Mission Control Center as the Canadarm2 berthed the Orbital ATK Cygnus commercial cargo craft to the Harmony node of the ISS on Jan. 12, 2014.

items to be disposed off or to be returned to Earth. See Figure 10.

One to several months after arriving at the ISS, the visiting vehicle will depart and conclude its mission. The crew uses the SSRMS to grapple the vehicle and unberth it from the ISS. The crew then maneuvers the SSRMS to the release position and releases the vehicle. The vehicle performs a short jet firing to initiate a flight trajectory away from the ISS, followed by a series of maneuvers to either destroy itself upon reentry or safely land in the Pacific Ocean for retrieval.

As elsewhere in the ISS Program, visiting vehicles have also evolved. Initially, it was envisioned that only one cargo vehicle at a time would berth to the USOS during a given period. It soon became apparent that as schedules shift, sometimes due to launch failures as noted

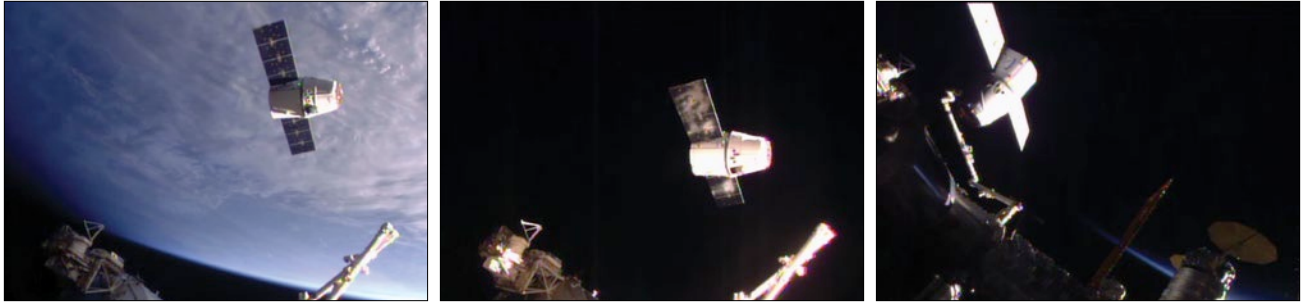


**Figure 10.** Astronauts Karen Nyberg (center) and Chris Cassidy (left), Expedition 36 flight engineers work inside the ESA ATV-4 “Albert Einstein” while docked with the station. ESA astronaut Luca Parmitano (right), flight engineer, is taking the selfie.

## Timing is Everything

As noted above, a great deal of planning is required to orchestrate the coming and going of visiting vehicles. Even with so much planning and training, the flight control team has to be ready at all times for problems and replanning. For example, a timing issue in September 2013 between the ISS and the first Orbital ATK mission affected how the Cygnus calculated its relative position, thus causing an automated abort of the rendezvous. The rendezvous could not be immediately resumed since it took the flight control team some time to determine what had happened but also to allow for the docking of the Soyuz that carried the Expedition 37 crew. The uncrewed cargo vehicles have the ability to loiter for several days, whereas the priority is to get the crew to the ISS as quickly as possible.

Similar flexibility with a twist was required in September 2008 when the first ATV, called “Jules Verne,” was preparing to be undocked from the ISS. It was scheduled to undock on September 5 and a new Progress vehicle was scheduled to launch on September 10 and dock to the same port. However, MCC-H was in the process of shutting down to prepare for Hurricane Ike as it headed for Houston. The NASA flight control team worked quickly to safely complete the undocking. This scenario was never expected to occur during a hurricane, but the tight schedule required the team to adapt. Five days after conducting the successful undocking, NASA dispatched flight control teams to two different locations to set up one temporary (undisclosed location) and a more permanent (Marshall Space Flight Center in Huntsville, Alabama) backup ISS control center in advance of evacuating MCC-H. Both were used.



**Figure 11.** A view from the external cameras on the ISS showing the capture and berthing at Node 2 on April 10, 2016, of the SpaceX Dragon while the Orbital ATK Cygnus, which arrived previously on March 26, is parked on the nadir side of the Node 1 module.

above, missions might overlap. More flexibility would be possible if two places were available for the cargo craft to berth on the USOS. After a significant amount of work, a second berthing port was added to the nadir side of the Node 1 module in addition to the one already present on the nadir side of Node 2. In the spring of 2016, two vehicles—a Dragon and Cygnus—were berthed to the space station at the same time, as seen in Figure 11.

## More to Come

As with the ISS itself, vehicles that visit the space outpost are evolving as well. NASA purchased the services of the private companies SpaceX and Orbital ATK that build the Dragon and Cygnus vehicles, respectively, under the Commercial Resupply Services (CRS) contract, which was awarded in 2008. In January 2016, NASA announced the second phase of the supply missions, known as CRS-2. In addition to SpaceX and Orbital ATK, NASA selected Sierra Nevada Corporation, which is building the Dream Chaser spacecraft

(Figure 12), to provide cargo missions. Sierra Nevada Corporation is expected to fly the first Dream Chaser mission in 2020.

Following the retirement of the Space Shuttle, the ISS became completely dependant upon the Russian Soyuz to transport astronauts to and from the space station. Beginning in 2010, NASA

partnered with commercial aerospace companies to develop crew transportation subsystems, followed by later development phases—an approach that was modeled after the successful CRS program. In September 2014, NASA selected two companies—Boeing and SpaceX—to develop the CST-100 Starliner and Crew Dragon, respectively, for this task. The first flight tests are



**Figure 12.** The Dream Chaser cargo vehicle, to be developed by Sierra Nevada Corporation, berthed to the nadir port of the Node 2 module. It is estimated to fly in 2020.

anticipated to take place in 2018. See Figure 13. These new crew spacecraft will be able to carry up to four astronauts to and from the space station, which would bring the station crew size up to seven.

Unlike the cargo vehicles, which berth, the new crewed spacecraft will dock using a newly developed NASA Docking System. Cargo is often bulky, especially if a full payload rack is being sent to the ISS; therefore, these uncrewed cargo vehicles use the wider Common Berthing Mechanism described in Chapter 3. However, the crewed vehicles will not be transporting large pieces of cargo, and they must be able to quickly get away without requiring the robotic arm since the vehicles will also serve as the emergency lifeboat for the crew. SpaceX will control its Crew Dragon vehicle out of its Mission Control Center facility in Hawthorne, California. Boeing, partnered with the Flight Operations Division at Johnson Space Center, will operate the Starliner out of one of the control rooms in Houston that is known as Mission Control Center CST-100.

## Conclusion

Although the ISS is a technical marvel, having been built by multiple countries through many launches, supplying the remote outpost has been critical to its survival. When Space Shuttle Columbia was destroyed during reentry in 2003, the ISS had to reduce the number of resident crew members from the limit of three (at the time) to two. This was because the only cargo vehicle available was the Russian Progress spacecraft, which could



Image courtesy of Boeing



Image courtesy of SpaceX

**Figure 13.** CST-100 Starliner (top) and Crew Dragon (bottom) approach the forward docking port on the Node 2 module.

carry enough supplies for only two people. Today, four different vehicles can transport cargo to the ISS. As of 2015, more than 30 cargo missions have flown by the fleet consisting of the European ATV, the Japanese HTV, and the American Cygnus and Dragon vehicles. The new cargo craft—the Dream Chaser—should be added in a few years.







## Chapter 15 **Systems:**

Robotics—  
the Construction  
Equipment for  
the International  
Space Station



An image of the Canadian five-dollar bill features a spacewalker wearing a Canadian flag on the shoulder, the International Space Station robotic arm, and the Special Purpose Dexterous Manipulator.

**Brains, voice, heart, lungs, and circulation system—all are critical for life. The International Space Station (ISS) requires the technical versions of such systems, as well. Just as important are “limbs”—most notably, the giant robotic arm of the space station.**

The robotic arm is fundamental for executing spacewalks, conducting repairs, and performing cutting-edge research. The ISS would not exist without this limb, which played a key role during construction of the space station. For 15 years, the ISS was essentially a construction site, albeit one that orbited at 28,163 km/h (17,500 mph). As with any construction site, cranes are required to move large pieces into place. The focal point of space station assembly “job site” was the main robotic arm. This machine, measuring 17.6 m (57.7 ft) in length, moved massive objects such as large pressurized modules and truss

segments, as well as transported spacewalkers to areas that would otherwise be unreachable. The arm is part of a complex system that is extremely flexible, allowing the arm to move to different work sites, grab other arms that can do fine detail work, and even repair itself. In fact, because of this flexibility, the entire system is known as the Mobile Servicing System (MSS).

This chapter focuses on the MSS; in particular, the space station crane (i.e., the Space Station Remote Manipulator System) and the components that make up the supporting equipment (i.e., Special Purpose Dexterous Manipulator [SPDM], Mobile Transporter [MT], and Mobile remote server Base System [MBS]). Operation of the MSS is discussed, which will explain how the crew and a blended NASA and Canadian Space Agency flight control team work together. The evolution of

this symbiotic relationship is also presented, as well as some of the challenges that the flight control team has faced over the years, beginning with the birth of the systems during a time of crisis. Since its activation, the robotic arm has played a critical role in increasingly complex operations.

The Japanese contributions of robotic systems are the Japanese Experiment Module Remote Manipulator System Main Arm and the Small Fine Arm. The European Robotic Arm is scheduled to be installed in or around 2018. Activation and operation of this arm is tied to the arrival of the Russian module called the Multipurpose Laboratory Module (see Introduction). As with other systems provided by international partners, these are not discussed further here. This chapter, however, focuses on the Canadian-built robotic system. Collectively, the components are called the MSS.

## Robotic Systems on the International Space Station

As part of a longstanding partnership between NASA and the Canadian Space Agency (CSA), Canada's main contribution to the ISS has been the robotic systems. Canada already had an established capability in space robotics. The Canadian government managed and funded the design of the Shuttle Remote Manipulator System (SRMS), commonly referred to as Canadarm. The first shuttle-based Canadarm was launched on Space Transportation System (STS)-2 in

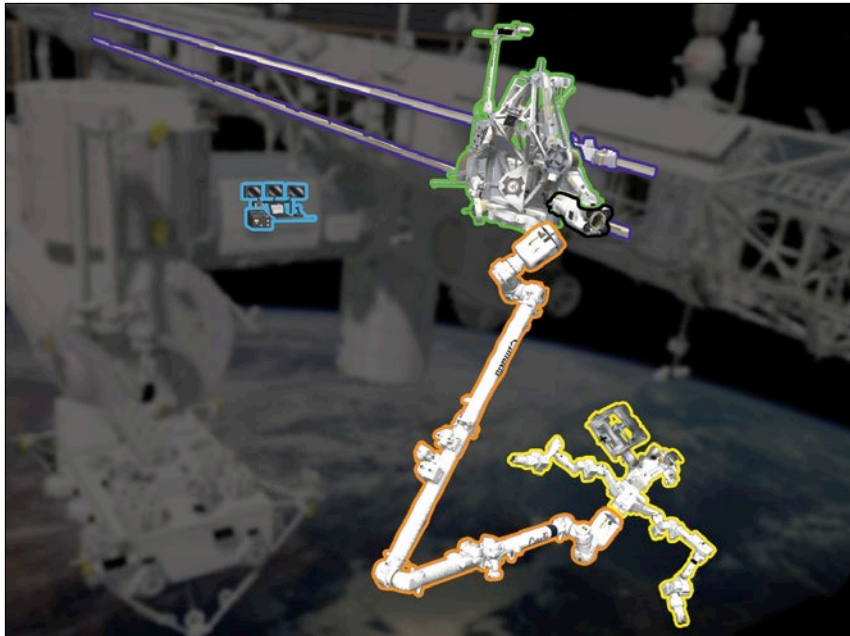
November 1981, with operational responsibility residing with the NASA Flight Operations Directorate. After President Ronald Reagan's invitation in 1984 for international friends and allies to participate in the Space Station Freedom Program, Canada chose to contribute a suite of robotics elements that would be critical to space station assembly and maintenance. The formal agreements were signed between the United States and Canada on September 29, 1988—the same day the space shuttle returned to flight following the post-Challenger hiatus.

The centerpiece of the ISS MSS is the Space Station Remote Manipulator System (SSRMS), dubbed Canadarm2 by the CSA. Since it is larger than the shuttle arm by 2.0 m (6.6 ft) and wider by 2.0 cm (0.8 in.), it is also referred to as the “big arm.” Although similar to the shuttle arm in many respects, the new space station arm represented an evolutionary step forward. Table 1 lists the key characteristics of the SSRMS with an overview of the MSS shown in Figure 1.

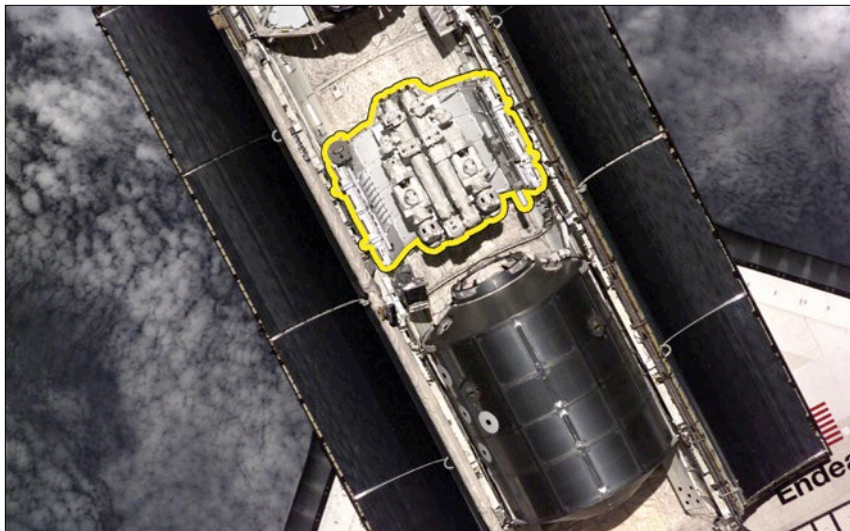
Early assembly of the ISS (including supporting spacewalks) was

**Table 1.** Summary of the SSRMS properties, based on data provided by CSA (<http://www.asc-csa.gc.ca/eng/iss/canadarm2/c1-c2.asp>).

Detail	International Space Station Mobile Servicing System (Canadarm 2)
<b>Mission Profile</b>	Permanently in space.
<b>Range of Motion</b>	Moves end-over-end to reach many parts of International Space Station in an inchworm-like movement; limited only by number of Power and Data Grapple Fixtures (PDGFs) on the station. PDGFs located around the station provide power, data, and video to the arm through its Latching End Effectors (LEEs). The arm can also travel the entire length of the space station on the Mobile Base System.
<b>Fixed Joint</b>	No fixed end. Equipped with LEEs at each end to provide power, data, and video signals to arm.
<b>Degrees of Freedom</b>	7 degrees of freedom. Much like a human arm: shoulder (three joints), elbow (one joint), and wrists (three joints). However, Canadarm2 can change configuration without moving its “hands.”
<b>Joint Rotation</b>	Full joint rotation. Joints (7) rotate 540 degrees. Larger range of motion than a human arm.
<b>Senses</b>	Force moment sensors provide a sense of touch. Automatic self-collision avoidance.
<b>Length</b>	17.6 m (57.7 ft)
<b>Weight</b>	1,800 kg (3,968 lbs)
<b>Diameter (exterior diameter of composite boom)</b>	35 cm (13.8 in.)
<b>Mass Handling Capacity</b>	116,000 kg (255,736 lbs)—design case handling payload.
<b>Speed of Operations</b>	Unloaded: 37 cm /sec (1.21 ft /sec) Loaded: Station Assembly—2 cm/sec (.79 in./sec) EVA Support—15 cm/sec (5.9 in./sec) Orbiter—1.2 cm/second (.47 in./sec)
<b>Composition</b>	19 plies of high strength carbon fiber—thermoplastic
<b>Repairs</b>	Designed to be repaired in space by replacing Orbital Replacement Units. Built-in redundancy.
<b>Control</b>	Ground operation or astronaut control
<b>Cameras</b>	Four color cameras (one at each side of the elbow, the other two on the LEEs)



**Figure 1.** This artist's rendering shows the robotic equipment discussed in the chapter. The SSRMS is outlined in orange. The Robotics Workstation (RWS) is outlined in blue. (Note: in this graphic, the pressure shell of the US Lab is cut away to show the location of one RWS. The second RWS is located in the Cupola attached to Node 3 [the blue dome near the white SSRMS.]) The MBS is outlined in green. The Mobile Transporter and rails are outlined in purple. The SPDM is outlined in yellow.



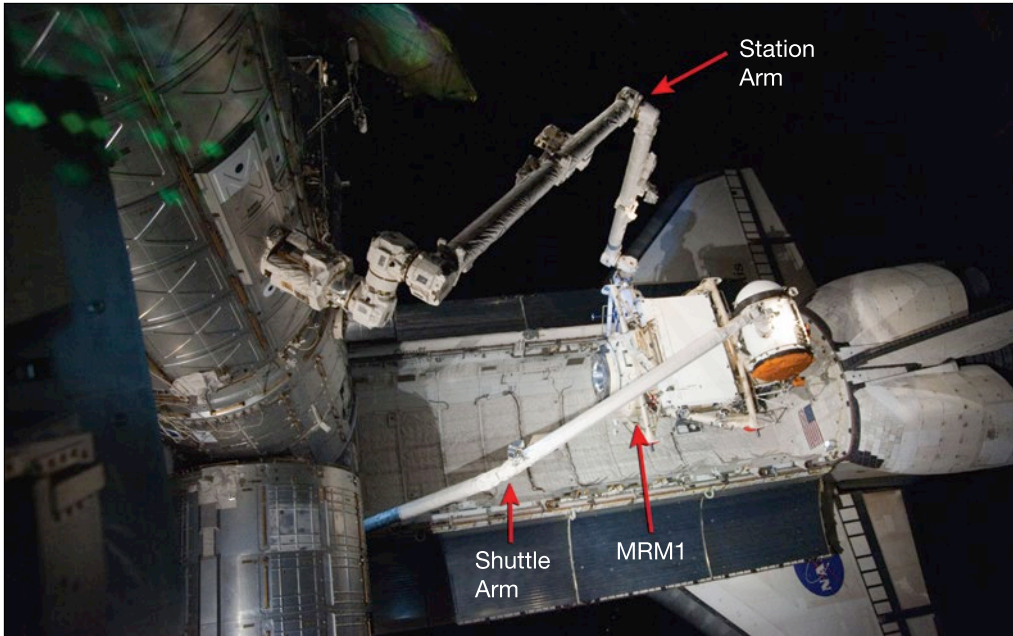
**Figure 2.** This photograph, taken from the space station during rendezvous operations, shows the Space Shuttle Endeavour payload bay. The SSRMS, in its launch configuration, is seen folded up on a pallet (outlined in yellow) in front of the Raffaello Multi-Purpose Logistics Module (MPLM). For scale, the MPLM is 6.6 m (21.6 ft) in length and 4.6 m (15.1 ft) in width. During the mission, the shuttle arm removed the pallet with the SSRMS from the payload bay and installed it on the ISS. Spacewalking astronauts later unfolded the arm. The first payload ever handled by the SSRMS was the pallet on which it flew. The SSRMS removed the pallet from the space station. The pallet was then handed back to the shuttle arm, which placed it in the shuttle payload bay for return to Earth.

performed using the shuttle arm. This included installing the Port 6 (P6) and zenith (Z1) truss segments on STS-97/ISS-4A and the laboratory module on STS-98/ISS-5A. The SSRMS did not arrive on the space station until STS-100/ISS-6A in April 2001 (Figure 2). Even after the SSRMS arrived, the shuttle arm was often used to hand, back and forth, modules and other equipment going to, or returning from, the ISS (Figure 3).

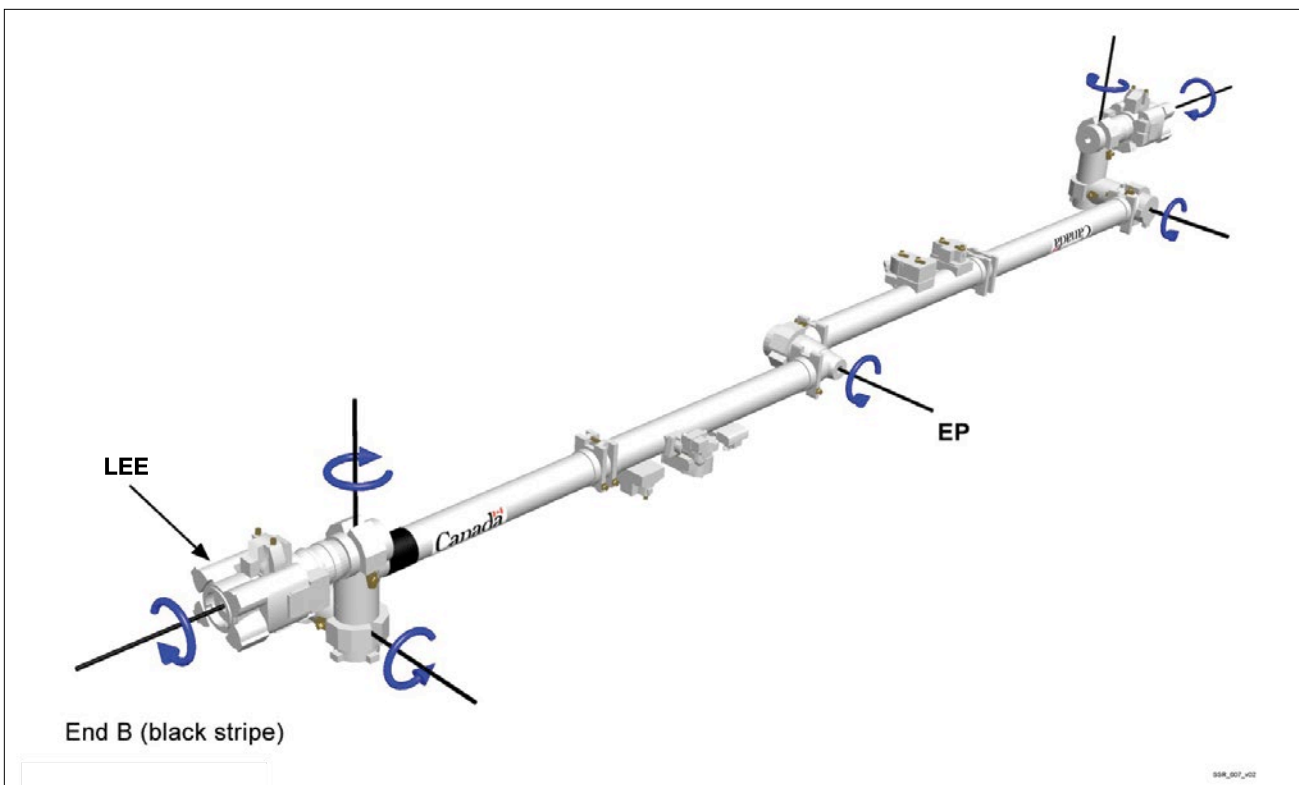
### **Space Station Remote Manipulator System**

The core part of the station robotic systems is the SSRMS, shown in Figure 4. The SSRMS elbow joint (the joint in the middle of the arm) is offset, or side-by-side, which allows for greater mobility. For comparison, human arms are attached to the shoulder with “in-line” joints. If the elbow is bent, a person can touch a finger to his or her shoulder, but can’t rotate past the point where the forearm touches the bicep. The Canadarm also had joints that could rotate only up to 160 degrees. The amount of possible rotation depended on the joint. The offset elbow joint of the station arm allows the booms on the arm (the “forearm” and the “bicep”) to rotate past each other. The joint can rotate a total of 540 degrees. The pitch and yaw joints at the end of the booms are also offset and have 540 degrees of rotation, with the yaw joint being slightly longer to help reduce the chance of the arm hitting itself in what is known as a self-collision. The final joint on either end of the arm, underneath the end effector, is called a roll joint. The roll

Drawing courtesy of CSA



**Figure 3.** During STS-132/ISS-ULF4 in 2010, Space Shuttle Atlantis delivered the Russian Rassvet (“Dawn”) Mini Research Module (MRM)1 to the space station. In this picture, which was taken during the mission, MRM1 has been removed from the payload bay by the shuttle arm (bottom). The station arm (closer to the camera) is also grappled to the module. The manipulators, controlled by astronauts inside both the space station and the shuttle, are performing what is called “handoff” between arms. The station arm subsequently installed MRM1 on the Russian Segment of the ISS.



**Figure 4.** Drawing of the station arm showing offset joints and the positive direction of motion for each of the seven joints is shown by the blue arrow. The direction in which each of the five joints can rotate is shown in blue. A black band is seen at the end of Boom B to differentiate one of the ends.

Drawing courtesy of CSA

joints cannot be offset with anything; however, as with the other joints, they have 540 degrees of motion. A large black stripe is located on one of the booms (Boom B) since either end can be fixed to structure while the other end is used to manipulate an object. The boom at the other end is referred to as Boom A. Four cameras—one at each end and two at the elbow (not shown)—allow the operator to see what is being grappled and help prevent collisions between the arm and structure.

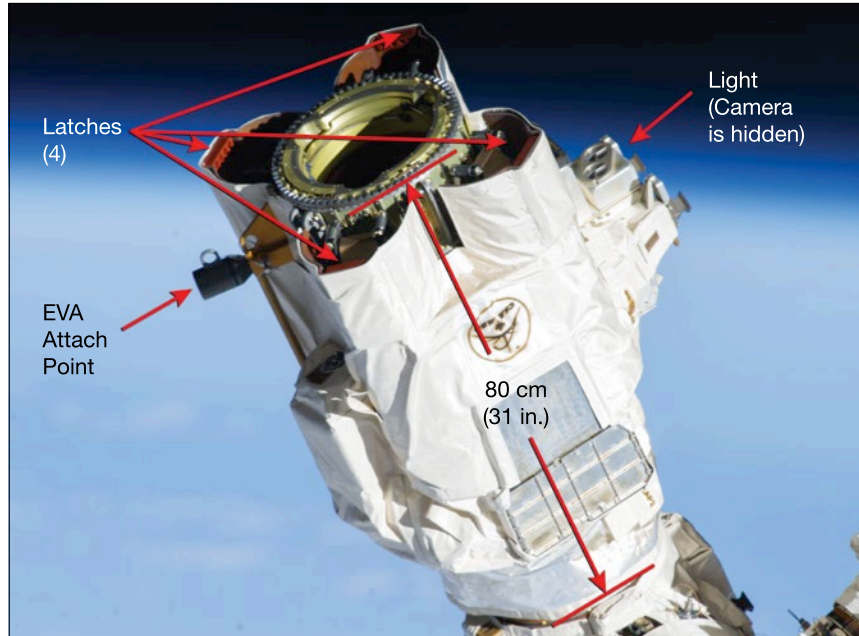
One of the most critical parts of the arm is the Latching End Effector (LEE). A LEE is located on each end of the arm. One LEE allows the arm to grab payloads while the other acts as “base” for the arm when attached to the space station (Figure 5).

The LEE is similar in size and shape to a barrel with the lid removed.

Four latch mechanisms, an attachment point of an extravehicular activity (EVA) boot plate that allows an astronaut to attach to the arm (See Chapters 17 and 18), and a camera with a light are all situated around the outside of the LEE.

Grabbing or attaching payloads is accomplished using a combination of snares and latches. The snares are braided wire ropes on a rotating ring. When the inner ring is rotated, the snares form a web across the open end of the LEE (Figure 6).

To capture a payload, the snares close across a metal rod called a grapple shaft on the grapple fixture. An operator maneuvers the LEE so that the grapple shaft is inside the open cavity of the LEE. The snares close around the grapple shaft and a semisphere on top of the pin prevents the rod from sliding out of



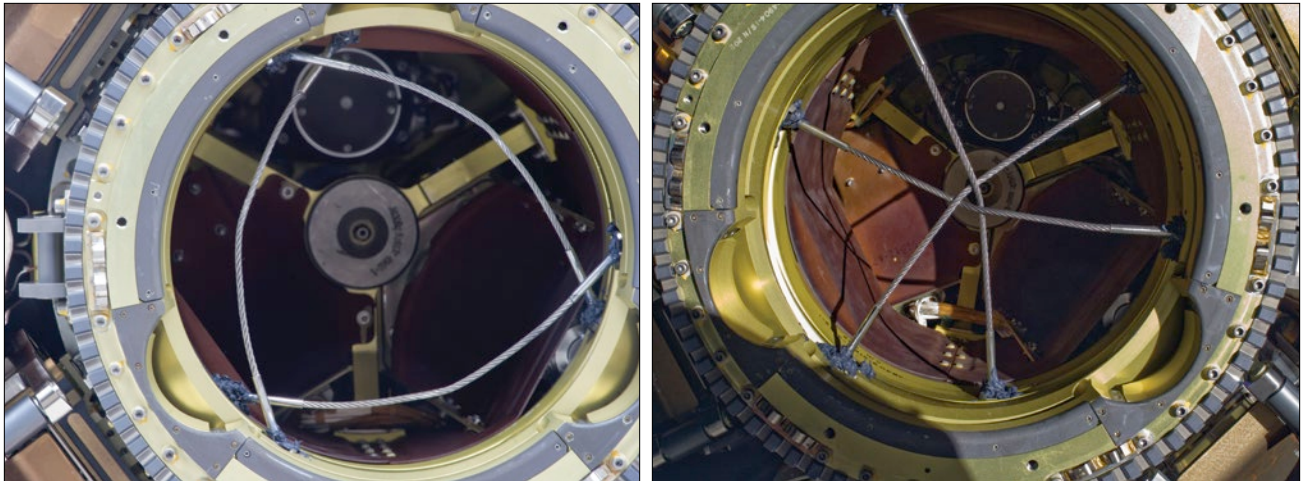
**Figure 5.** A LEE. The lights on top of the camera are to the right in this image. The EVA attach point allows a spacewalking astronaut to attach a foot restraint, attach his or her boots, and “ride” the arm (see Chapters 17 and 18). The snare cables in this image are completely open and fit flat against the opening.

the snares. The three lobes (Figure 7) in the grapple fixture align with the indentations of the LEE, thereby allowing the arm to snugly align to the base of the grapple fixture. The arm has a strong hold on the payload once the carriage has retracted and the back plate of the grapple fixture is tight against the face of the LEE. Some grapple fixtures (Figure 7) have additional features that the SSRMS can latch onto, which can provide power and data. This special type of grapple fixture is called a Power and Data Grapple Fixture (PDGF). Behind four small, spring-loaded doors are electrical, data, and video connections. A PDGF also has an outer ring on the baseplate. This outer ring is composed of many small teeth called a curvic coupling. A matching set of teeth are located on the LEE (Figure 5). As a PDGF

is grappled, the curvic coupling enables precise alignment between the LEE and the grapple fixture, thus allowing for various service connections to be made. When the arm grapples a PDGF, umbilicals are extended from the LEE, which will pass through the protective doors and connect to power, data, and video.

The ability to provide power, data, and video through a PDGF to the arm is major component of the mobility in the MSS. Several PDGFs are positioned around the ISS. These PDGFs, coupled with the LEEs, allow the SSRMS to reach worksites that a fixed robotic arm could not. The arm is connected to a PDGF at both ends to change locations. One end is then released and moved to another PDGF. This





**Figure 6.** (Left) Looking down the open end of the LEE, showing the snares in their open position. A ring that is holding the snares begins to rotate when the robotic arm is over a grapple pin (Figure 7), thus causing the snares to trap the rod. (Right) In this image, the inner snare mechanism has rotated, thus causing the LEE snare cables to form a web across the opening.

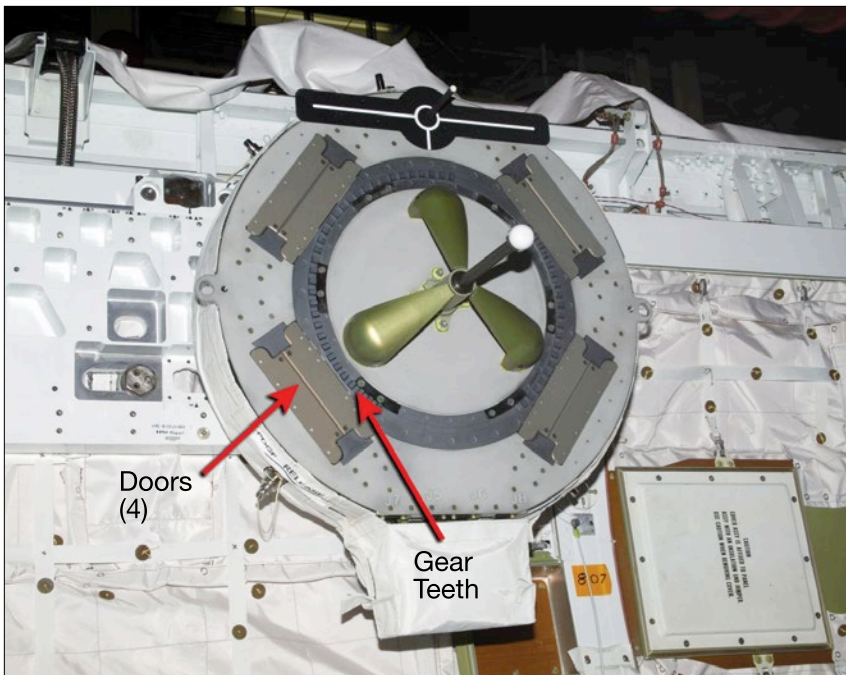
can be repeated multiple times to move the arm around. In the vernacular, the arm is designed

to “walk” much like a Slinky<sup>®</sup> toy (Poof-Slinky, Inc., Plymouth, Michigan) or an inchworm.

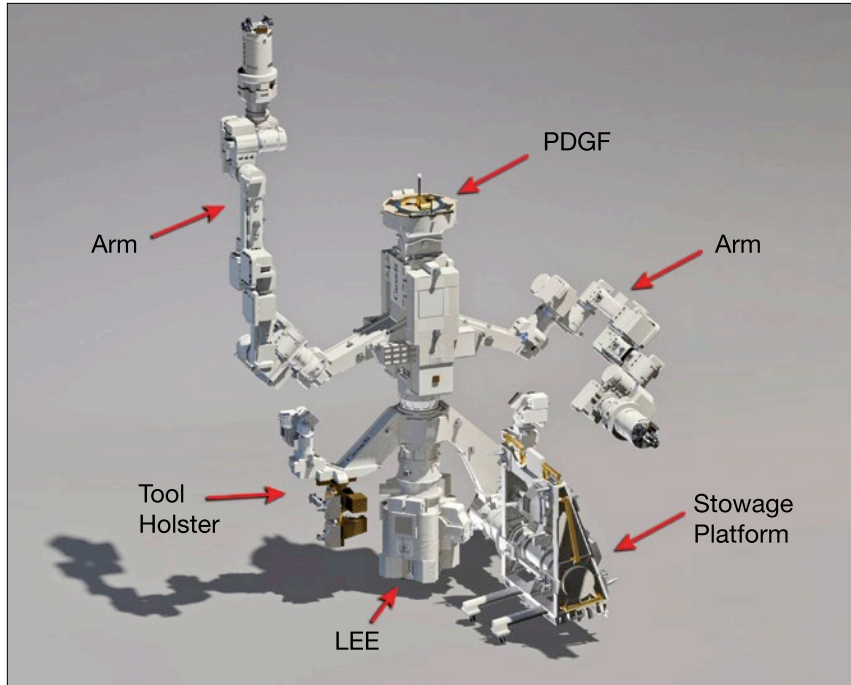
### ***Special Purpose Dexterous Manipulator***

Another robot on the ISS, the SPDM (Figures 1 and 8), arrived on STS-123/ISS-1J/A in 2008. The SPDM is comprised of several components, including a LEE, a Power Data Grapple Fixture, two robotic arms, a tool holster, and a stowage platform. The fine control of the SPDM arms facilitate the manipulation of various hardware components on the outside of the ISS, thereby allowing for a number of operations that do not require a spacewalking astronaut. For instance, the SPDM allows the replacement of failed components such as the Remote Power Control Modules (see Chapter 9).

To change out failed items such as Remote Power Control Modules, the SSRMS first retrieves the SPDM from wherever it is currently stowed and maneuvers it close to



**Figure 7.** A PDGF. The grapple shaft is in the center with the white semisphere at the end. The three gold lobes align with identical indentations on the LEE to help align the arm. A black-and-white target allows the operator, using a camera at the end of the LEE, to make sure the arm is directly over the pin. Note the curvic coupling (gear teeth) and the four doors.



Drawing courtesy of CSA

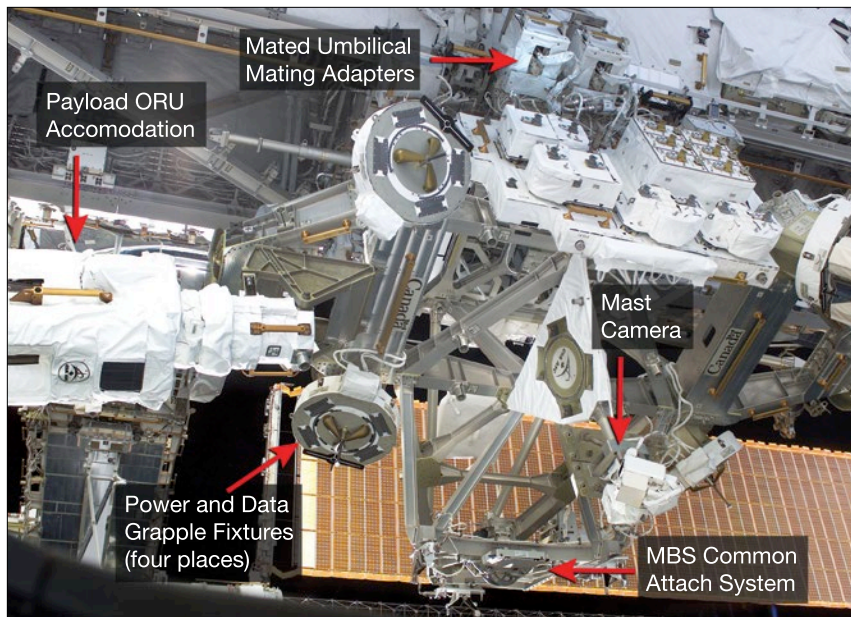
**Figure 8.** This drawing of the SPDM shows the individual elements including the LEE, where it can be mounted, or a PDGF, where it can be grappled by the arm.

a Cargo Transportation Carrier, which contains a spare unit. Using one of its arms, the SPDM opens the container and retrieves one of the new Remote Power Control Modules. The other arm would then close the container. A similar process is repeated at the site of the failed component to swap units, and then again to return the failed unit to a storage location.

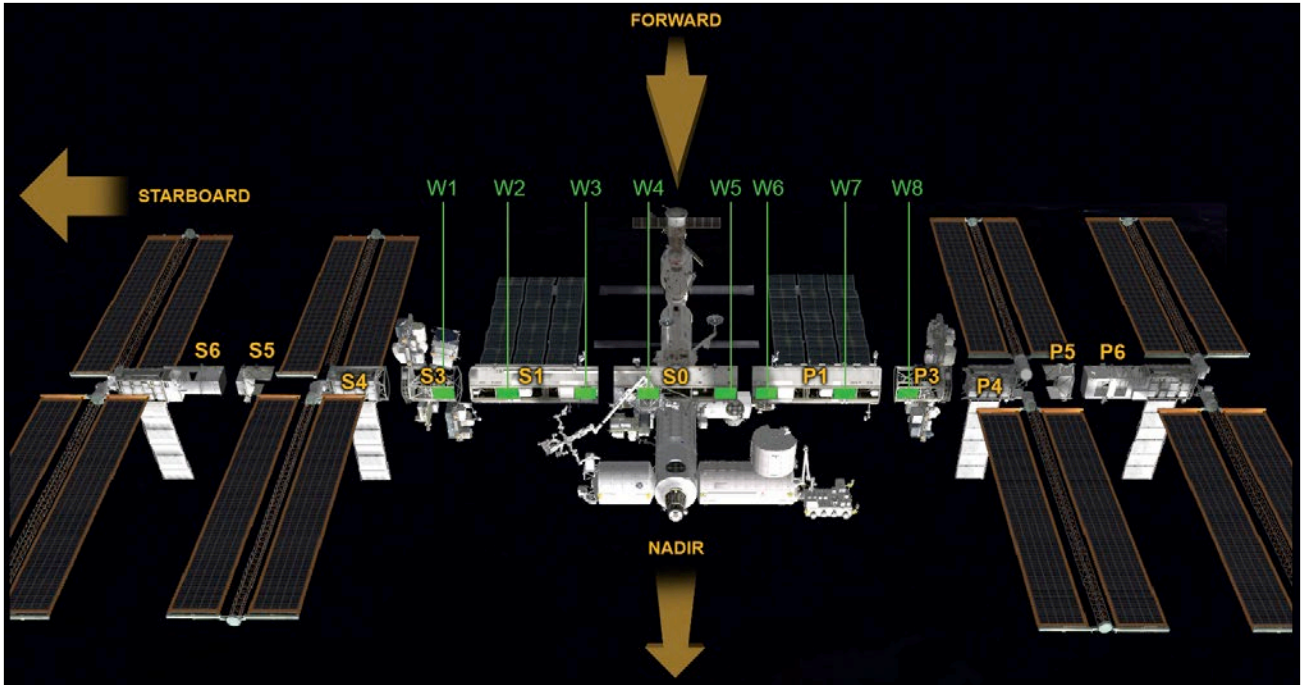
### **Mobile Remote Servicer Base System and Mobile Transporter**

In addition to “walking” around the station, the SSRMS can also hitch a ride and be carried along the truss. The MBS is a workbench for the SSRMS and SPDM (Figures 1 and 9). It contains four separate PDGFs that can be used as base points for either system. Depending on whether the operation to be performed is port or starboard, zenith or nadir, one of the four base points will be ideal for the activity.

The MBS sits atop and is permanently attached to the NASA-built Mobile Transporter. A set of “tracks” is built in along the forward face of the ISS truss structure. These tracks allow the transporter with the MBS to move up and down the truss. Often, the transporter is moved to a different worksite, as seen in Figure 10, so that the SSRMS can reach some area of the space station. For those moves, the SSRMS and/or the SPDM are first attached to the MBS (Figure 11) and the transporter relocates everything to a new worksite. However, the transporter cannot stop at just any

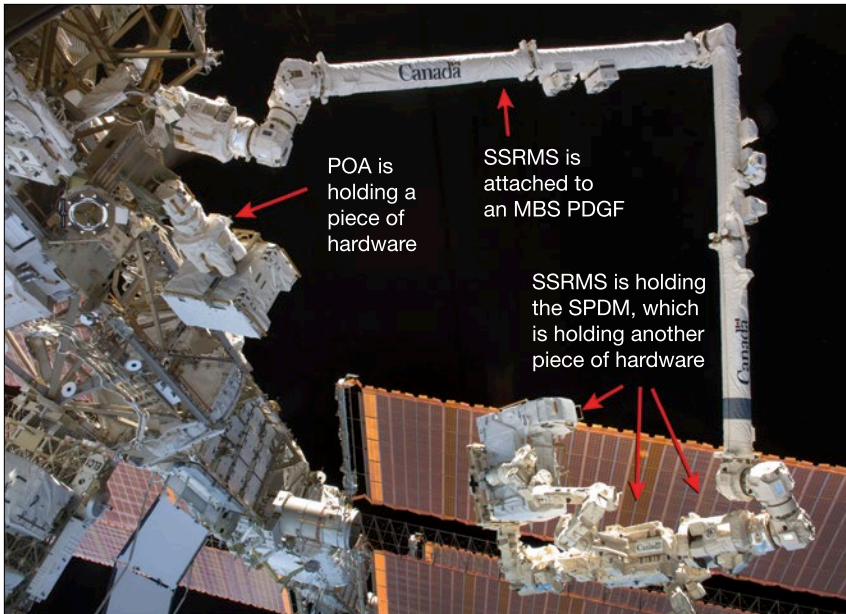


**Figure 9.** This picture shows the MBS right after it was delivered to the space station on STS-111/ISS-UF-2. Note the four PDGFs, one of which has the arm attached, the Payload Orbital Replacement Unit Accommodation, the Mast Camera and the Umbilical Mating Adapters mated at a worksite. The MBS Common Attach System similar to the UCCAS is also shown. See also Chapter 3.



Drawing courtesy of CSA

**Figure 10.** Locations where the Mobile Transporter can park along the truss of the ISS are listed as Worksite (W)1 through W8. W1 is located on the Starboard 3 (S3) truss segment. Worksites W0 and W9 are not shown and would be on the S4 and Port 4 (P4) trusses, respectively.



**Figure 11.** This picture taken during Expedition 26 shows the SSRMS based on an MBS PDGF holding the SPDM, which is attached to an Orbital Replacement Unit. The Payload Orbital Replacement Unit Accommodation (POA) is also holding another Orbital Replacement Unit.

location along the truss. It can stop and “plug in” to the power and data networks at specific locations. Altogether, there are 10 transporter worksites on the ISS numbered 0 (W0) through 9 (W9), but only eight of them are actually used. The last two worksites (W0 and W9) are located outboard of the Solar Array Rotary Joint (see Chapter 9). The rails were never installed on those outer segments; thus far, those outboard worksites have never been required for operations.

## Mobile Servicing System Operations

Operations of the robotic systems are unique in a number of aspects and, much like the ISS, have evolved over the years. On the Space Shuttle, the Canadarm was controlled by the astronauts, which was the initial plan for the MSS. Today, the ISS systems can be operated by either the astronauts or the flight control team based in Houston or Montreal. Where possible, it is preferable to perform operations from the ground to free up the astronauts to focus on scientific research.

### Crew Operations and the Robotic Work Station

The crew interface to the robotic systems is the Robotics Work Station (RWS). The ISS includes two identical RWSs (Figures 1 and 12). One is located in the Laboratory Module and the second is located the Cupola.

Their key components include a control panel, two hand controllers for control of the arm, and three video displays to provide camera views to the astronaut operator. The control panel controls key functions such as how fast the arm can move and which of the many external cameras are visible on one of the three monitors.

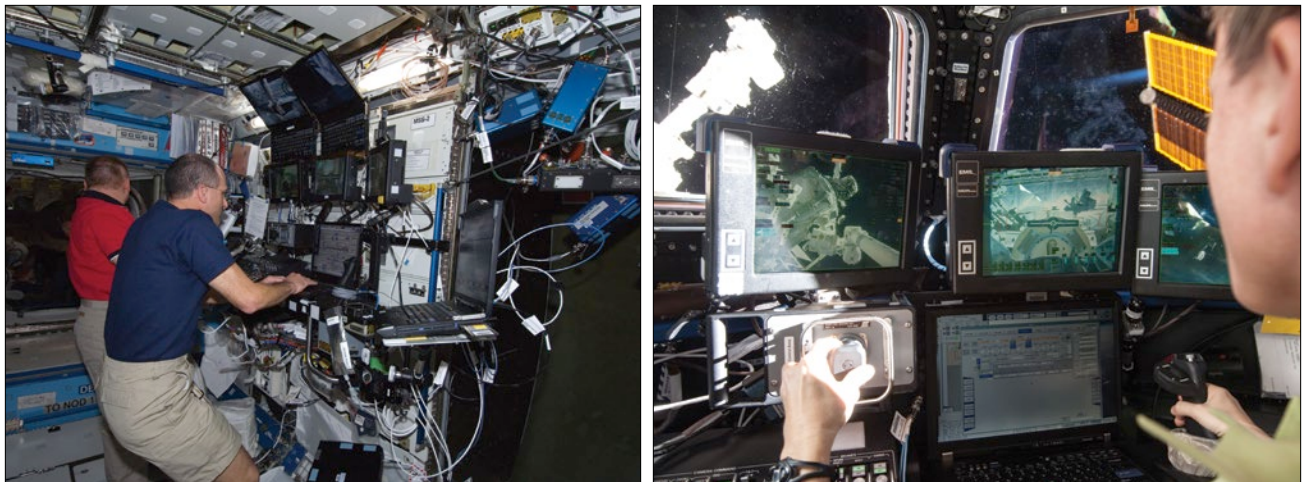
Two hand controllers are located on each work station. These allow crew members to control arm motion and perform capture-and-release operations. A crew member who maneuvers the arm via the RWS hand controllers is said to be “flying the arm.”

The monitors are used to provide situational awareness cues to crew members while they are operating the system. Several cameras on the ISS structure and several cameras on the robotic system can be displayed. When grappling a free-flying spacecraft, for example, the crew members will display the camera

that is mounted on the tip of the arm, which allows them to see visual cues about the alignment of the end effector relative to the grapple pin. If the robotic system is being used to maneuver a spacewalker, a camera on the ISS structure might be used to monitor how close his or her boot plate is to the station structure.

### Ground Operations and the Flight Control Team

Unlike robotic arms that move fast and easily, such as those in science fiction movies, the motion of the space station systems requires long and careful planning by the Robotics Officer (ROBO) team. If the operation is something that can be performed methodically, such as replacing a piece of hardware on the exterior of the ISS, and which can be planned well in advance, the flight control team will perform the operations; otherwise, the crew may perform the task. For more dynamic operations—



**Figure 12.** (Left) Expedition 18 Commander Michael Fincke (left) and STS-126/ISS ULF-2 Mission Specialist Donald Pettit (right) work the controls at the RWS in the US Laboratory on November 17, 2008. The three monitors in the middle can be used to view any external camera on the ISS. Additional computers are used to display a graphical representation of the arm or video from other sources (e.g., from the shuttle payload bay). The laptop that Don Pettit is using displays the timeline and procedures. Today, the Laboratory RWS is only used as a backup for the one in the Cupola. (Right) Expedition 36 Flight Engineer Karen Nyberg prepares to capture the “Kounotori” H-II Transfer Vehicle-4 on August 9, 2013. Her hands are on the two-hand controllers and the three video monitors are at her eye level with a laptop in the center showing the joint angles of the robotic arm. The tip of a solar array is visible in the window on the right while the robotic arm is seen in the window on the left.



**Figure 13.** Expedition 47 ROBO Jason Dyer (CSA) on console in Mission Control Center-Houston during rendezvous with Orbital/ATK Cygnus OA-6 cargo vehicle in March 2016. Various data are displayed on the computer monitors including a graphical display below the ROBO sign on the left, similar to what the astronauts use, showing the current position of the robotic arm. On the left side of the front wall displays are six images from external cameras on the ISS. The middle wall display tells the flight director (not shown) the location of the ISS in relation to the Earth, as well as the vehicle orientation. The far-right display shows the commands being sent to the ISS and any alarms that are present.

e.g., capturing a visiting vehicle or supporting a spacewalk—the on-board astronauts will execute the procedure.

In addition to providing the hardware, CSA also provided flight controllers to operate the MSS. Whereas the other international partners control their contributions from a control center in their host countries with their own flight director, the MSS is controlled from Houston, Texas, under the supervision of the NASA flight director. In Houston, the system team, led by the ROBO (see Introduction) is made up of approximately 50% CSA employees. Initially, the CSA robotics support

room in Montreal provided primarily engineering support during robotics operations, which was the equivalent of the Mission Evaluation Room discussed in the Introduction. Over time, the capabilities of the facilities and operators in Montreal grew. Today, it now serves as a control center. Here, the MSS systems and MSS task flight controllers support the ROBO (Introduction Figure 10) and, on occasion, ROBO supports from Montreal with the backroom support in Houston (Figure 13).

In the early days of robotic operations on the ISS, the flight control team powered the MSS on or off but

left the dynamic operations to the crew. After a serious ISS computer system failure on STS-100/ISS-6A (see below), the team began to imagine how operating the robotic systems from the ground could actually work. Today, many of the SSRMS operations, all translations of the systems using the Mobile Transporter, and all of the SPDM operations are actually performed by the ground team. The Bigelow Expandable Activity Module was installed in April 2016, completely by the ground team. The astronauts performed only the time-critical steps with the Common Berthing Module.

In 2004, the ground team uplinked approximately 3,500 commands to the MSS. This number is expected to rise to greater than 80,000 in 2018.

Ground control does not employ hand controllers. Although the ROBOs could perform operations with hand controllers, the latency involved in issuing commands to the ISS via the Tracking and Data Relay Satellite System preclude them from performing the subtle motions required for operations using hand controllers. Therefore, personnel in the Mission Control do not “pilot” the arm like the crew does. Instead, flight controllers use pre-calculated, automatic sequences of instructions that tell each joint exactly how far to turn, at what rate, and in which order. During motion of the arm, the ROBO then monitors the system to verify it is executing the instructions correctly. These “ground control”

operations use the various camera views available to Mission Control Center-Houston as well as computer depictions of where everything is in relation to each other, driven by real-time telemetry from the ISS, to provide in situ awareness for the flight controllers who are flying the arm.

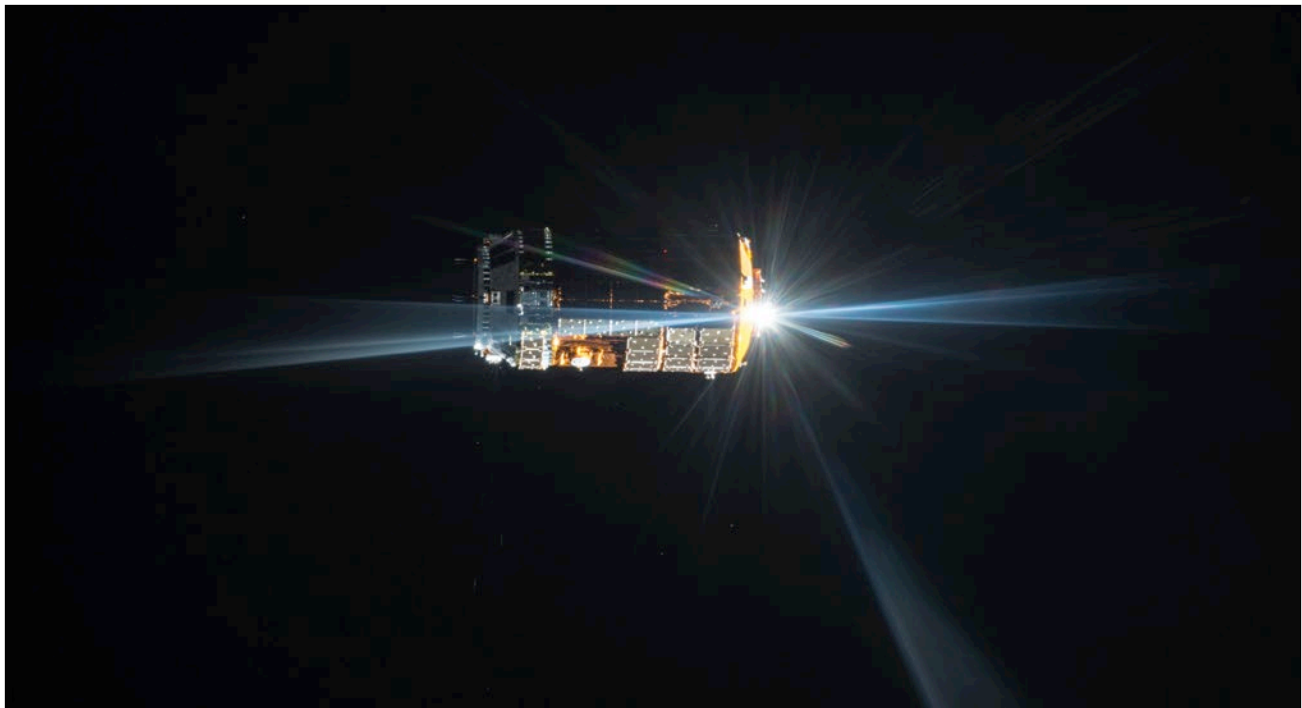
### ***Crew, Houston, and Canadian Ground Control Working Together—A Case Study***

Another key capability of the arm is to capture visiting vehicles (see also Chapter 14)—a process that is performed symbiotically between the ground and crew, as illustrated by the example of the fifth H-II Transfer Vehicle (HTV) cargo mission to the ISS. On August 15, 2015, the Japan Aerospace Exploration Agency launched the HTV5 “Kounotori 5” resupply vehicle toward the ISS.

Prior to the launch, flight controllers in Houston and Montreal attached the SSRMS to a PDGF on Node 2 and positioned it for the arrival of the visiting vehicle. After a couple days of free flight, HTV5 arrived underneath the space station and started slowly approaching the ISS on August 24 (Figure 14).

Over the course of a couple of hours, HTV5 moved closer to the ISS, orbiting just below the station (see “Are we there yet?” in Chapter 14). As the HTV moved closer, the crew on board the space station monitored the vehicle to verify it stayed within the approach corridor. The trajectory is designed such that HTV arrives at its station while keeping the position with its grapple fixture directly in front of the SSRMS LEE (Figure 15).

From that point, the on-board crew members take over. They maneuver



**Figure 14.** HTV5 approaching the ISS from underneath in August 2015. Sunlight reflecting off shiny surfaces on the vehicle cause the starburst pattern.



**Figure 15.** Flight Director Royce Renfrew and his team watch as the HTV5 arrives at the capture point, oriented such that its grapple fixture is directly in front of the LEE. The gold-colored material (left in the view) is part of the thermal covering of the vehicle. The white circle in the center of the gold-colored area is the grapple fixture. JAXA astronaut Koichi Wakata is sitting to the right of the Flight Director.

the arm to grapple the free-flying HTV5. Crews train extensively to be able to capture a vehicle that is not completely steady. The amount of hand/eye coordination and quick responses required to grapple a free flyer precludes the flight controllers in Houston or Montreal from being able to capture a vehicle. Once the HTV5 was captured, however, operations transitioned back to the ground. The ROBO took over the operations and maneuvered HTV5 to mate with the Node 2 nadir-facing Common Berthing Mechanism. Working in concert with the on-board crew members who operate the common berthing mechanism, the ground team installed the HTV5 on the Node 2 nadir port (Figure 16). See also Chapter 3.



**Figure 16.** The HTV5 being maneuvered toward the Node 2 nadir Common Berthing Mechanism on the ISS (top of image).

Several days after arrival, the SSRMS removed the exposed pallet from the HTV trunk. The pallet contained a new payload for the Japanese Experiment Module exposed facility. Additionally, two completed and used-up experiments were placed on the exposed pallet, which was eventually installed back in HTV5 for disposal (Figure 17). Reversing the capture and berthing process, the crew and ground removed the HTV from the ISS on September 28. The HTV then reentered the Earth's atmosphere and disintegrated.

### **Operational Challenges and Triumphs**

The SSRMS was delivered to the ISS in 2001 during the STS-100/ISS-6A assembly mission. Its activation and commissioning did not go smoothly, however. Not long after the arm had been activated, the ISS Primary Command and Control (C&C) Multiplexer/DeMultiplexer (MDM) (see Chapter 5) failed. This by itself was not critical. Computers are known to have problems now and then, which is why there are three of these on the ISS. However, by all indications, it was not a software problem; rather, the spinning hard drive had failed. The robotic systems relied heavily on the hard drive, reading critical programming files and recording key data about the system performance for flight controllers to monitor. Due to this reliance and use of the hard drive, it was first believed that the SSRMS was the cause of the failure. This concern increased when a second C&C MDM failed with a similar signature. The situation became more critical when the third



**Figure 17.** Astronaut Kjell Lindgren operates the Canadarm2 to install the exposed pallet into the HTV5 trunk area. The exposed pallet contained two experiments that had been completed and were ready for disposal. NASA video.

computer failed (see also “When Computers Crash,” Chapter 5). As the Onboard Data Interfaces and Network (ODIN) (see Introduction) flight control team figured out how to recover the computers, the robotics flight controllers were challenged to complete the operations on ISS-6A. These operations included returning the pallet on which the arm had been delivered back to the shuttle payload bay, and putting the arm in a safe configuration for the shuttle undocking. Fortunately, the arm was already activated when the MDMs failed because, normally, it loads all of its operating software from the same hard drives that failed. However, the crew's displays on the Portable Computer System, which is used for operating the SSRMS, also depend on the hard drive. ROBO was faced with a brand new robotic arm with no way to control it. Ground control had not yet been invented. The ground team worked rapidly to figure out how to have the crew maneuver the SSRMS to the needed position, and then have the astronauts fly the last little bit using the hand controllers, which still worked. This had to be

accomplished without the displays that the crew had been trained to use, and had to be executed under the direction of ROBO using video and telemetry on the ground. In this fashion, the team “limped” through the remaining robotics operations. After the mission, the ROBO team began working out concrete plans for ground control operations.

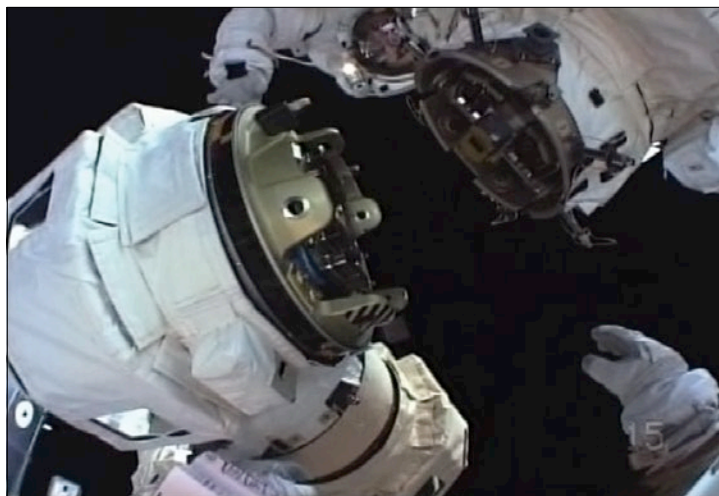
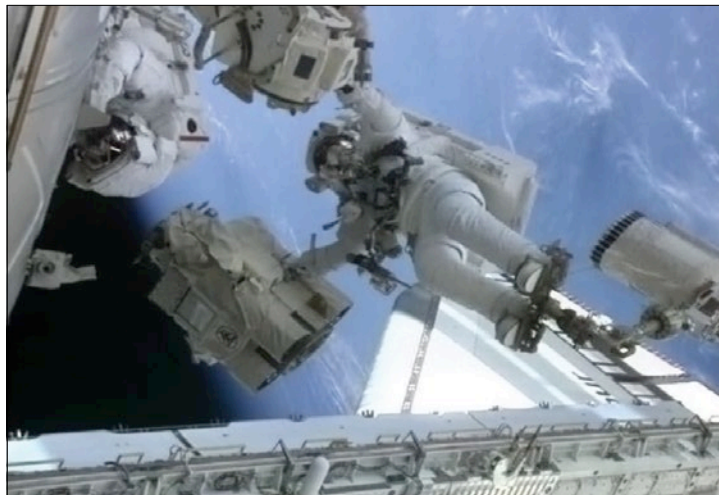
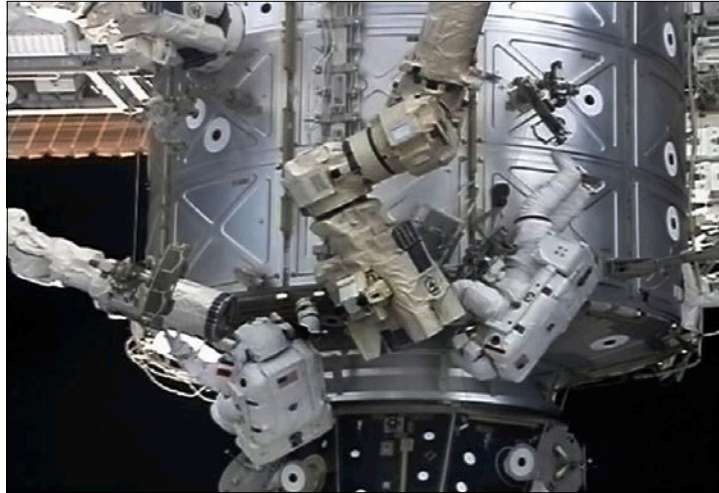
After detailed investigation by the flight control and engineering teams over several weeks, the flight control team determined that various problems during years of testing on the ground had caused the C&C MDM hard drives to literally fracture. Although this had significant implications for the space station since these computers controlled the US On-orbit Segment, it directly and severely impacted the robotic operations. The next mission, STS-ST-104/ISS-7A, was scheduled to deliver the airlock module; the SSRMS was required to successfully install it, as was the case with all remaining modules. Flight controllers worked hard over the next 3 months to install spare hard drives and reload all the software from scratch, including the robotics software. No further problems occurred during the installation of the airlock on ISS-7A.

New challenges soon emerged. On March 5, 2002, one of the two redundant electrical drive motors on the wrist roll joint on the “A” end (see Figure 4) failed on the SSRMS. Two systems were built into the arm so that if one failed during a critical operation, such as while installing a module, the second motor could take over and complete the job. However, to start a major operation with one system already failed



**Figure 18.** Mission Specialists Franklin Chang-

Diaz (red stripes on legs) and Philippe Perrin repair the wrist roll joint on STS-111/ISS-UF-2 on June 11, 2002. (Top) Crew members set up to perform the replacement. The shuttle robotic arm (Canadarm), in the left of the image, acts as a “cherry picker” to move one of the astronauts around. An articulating portable foot restraint near the feet of the other astronaut acts as a fixed boot plate during the repair. (Middle) After installing the portable foot restraint in the shuttle robotic arm, Chang-Diaz inserts his feet in the boot plate. Astronauts inside the shuttle maneuvered him to a location where he could remove the station robotic arm’s LEE. The LEE had to be removed to get to the failed roll joint, which is the next joint in line. (Bottom) The new roll joint, installed on the station robotic arm. Note how the multilayer insulation (MLI) on the new joint is much whiter in color than the MLI on the other station arm components. Off-gassing of the MLI changes its color over time on orbit. Both crew members in this picture are maneuvering the old LEE to reinstall it.



meant another failure could leave the arm stuck. A module stranded on the end of the SSRMS would be an extremely critical scenario. First, critical cables that provide power to heaters that keep the equipment from freezing have to be disconnected from the shuttle payload bay and reconnected after the module is berthed. Hardware stuck on the arm could freeze in a matter of hours. Second, this configuration would not be stable enough for the space shuttle to undock because vibrations and thruster plumes from the shuttle could jolt the SSRMS during the undocking process. This could damage the arm and even cause the hardware to be inadvertently released, possibly colliding with the ISS.

Since there was no way to replace only a motor on the arm, the entire joint containing the two drive motors would need to be replaced. Unfortunately, the spare joint motor could not be delivered and

installed until STS-111/ISS-UF2, after the STS-110/ISS-8A mission, which required the arm to install a key component of the ISS truss. The flight control team quickly put together a plan that would not require using that particular joint. The ROBO team developed a less-direct, complex sequence of maneuvers, enabled by the number of joints and the wide range of position each possessed. Although the primary system was working fine, the plan could not use that joint since a failure could put the arm in a position from which it could not be safely moved. However, it was never envisioned that the controllers would operate the software in this way, instead trying to figure out where the arm needed to go and calculating the most efficient way to get there. The ROBO team conceptualized the new software operations and the code was updated and tested quickly by CSA contractor MacDonald Dettwiler and Associates. Procedures were updated and the crew quickly retrained on the new operational scheme, which was now referred to as Degraded Joint OperationS (DJOPS). This entire process was performed in about 1 month and the ISS-8A mission was completed without incident. As with all situations, the flight director and flight control team spent a lot of time preparing for the worst and hoping for the best. Although the DJOPS was not used on that mission, it has become a standard capability.

During STS-111/ISS-UF-2, similar contingencies were prepared for the flight's robotics mission design, which involved the installation and deployment of the MBS, as well as spacewalk support. The SSRMS joint was successfully replaced (Figure 18) during the final spacewalk of the mission, taking place exactly 100 days after the joint failure first occurred. The new joint restored SSRMS fault tolerance, and the ISS assembly could continue on the subsequent shuttle missions with a fully functional arm.

## Conclusion

As with the construction of any project, whether it be a pyramid or a space station, tools are very important. The ISS robotic systems were critical for the successful assembly of the station. Based on the experience of the SSRMS, the space station robotic systems are both more complex, as well as significantly more capable and flexible. Although the ISS and its construction was developed with the MSS in mind, the SSRMS and its family of support equipment has been critical in supporting the daily operation of the station, often used in ways never originally imagined. External hardware, such as Remote Power Control Modules, are now routinely replaced using the SPDM, thus allowing the astronauts to focus on more scientific research. As discussed

in Chapters 17 and 18, the big arm was critical in numerous spacewalks, including spectacular contingency operations, and will continue to play a major role in the operation of the ISS. Robotic systems in science fiction movies tend to inspire awe by moving fast and operating with significant, often autonomous, intelligence. Reality is that the MSS on the ISS represents the state of the art today as it inspires awe in the robust and flexible manner that it supports an outpost on the edge of space. At the core of the system is the seamlessly blended NASA and CSA flight control team on the ground. Through discipline and competence, the ROBO team has pushed this tool to its maximum potential. Some form of robotics will be needed for humans venturing to the moon, Mars, and beyond. Operations in the harsh environment of space are best performed by robotics, leaving the human explorers safer in the relative protection of their spacecraft. The lessons learned after years of operating the space station robotic system will play a vital role in development and operations of those future robotic systems.





Chapter 16 Day in the Life:  
In-Flight  
Maintenance



Expedition 43 astronauts Scott Kelly (left) and Terry Virts perform in-flight maintenance on the Carbon Dioxide Removal Assembly. The inner workings of the device were removed from the rack in Node 3 and moved to the Japanese Experiment Module to provide a larger area in which the crew can work.

**A spacecraft as large, complex, and long-lived as the International Space Station (ISS) will clearly need to be maintained.** This is especially true when considering that the first components of the ISS have been in space since 1998. ISS maintenance

is the responsibility of both the crew and the flight control teams as part of day-to-day operations. Some components have limited lifetimes and need to be replaced or repaired on a periodic basis. Examples of equipment in this category include

dust filters, batteries, experiment igniter tips, overhead lights, and various waste filters in the regenerative life support system.

Other components need regular inspection to ensure they are still functioning, or are able to

function properly. Examples of such components include hatches, portable breathing masks, and other emergency equipment.

Finally, hardware may simply break unexpectedly and will need to be fixed for a certain component or system to be returned to operational use. When hardware fails on the space station, the way it fails or breaks may not have been envisioned when the hardware was being designed.

All of this work falls in the realm of in-flight maintenance (IFM). IFM occurs both inside and outside of the ISS. The primary focus of this chapter is the internal IFM, which is managed by the Operations Support Officer (OSO) console. External maintenance, which might include replacing a cooling pump or installing power cables, is managed by the extravehicular activity (EVA) console and is discussed in detail in Chapters 17 and 18.

The three categories of IFM include: Preventive Maintenance, Corrective Maintenance, and Diagnostic Maintenance. Preventive Maintenance entails all of the regular cleanings and inspections that are performed to ensure the proper operation of the hardware or system. Corrective Maintenance involves repairing or replacing hardware that has stopped working either because it is a consumable at the end of its life (e.g., a filter) or because it has broken unexpectedly (e.g., a light bulb or computer). Sometimes, hardware or equipment breaks and it is not obvious what has broken, especially in electronic equipment. In these cases, Diagnostic Maintenance is first required to

determine where faults might be located, and to help ground teams establish the best way to repair the hardware or situation.

## Maintenance Methodology

To the maximum extent possible, all ISS maintenance procedures are thoroughly reviewed and validated on mock-ups or flight-like hardware before the crew performs any procedures. OSO flight controllers, assisted by the necessary engineering specialists, develop methods and procedures for all maintenance tasks inside the ISS—from accessing and cleaning a filter, to the complicated replacement of a valve in the Carbon Dioxide Removal Assembly. Whenever possible, these procedures are tested on the ground prior to being given to the crew to ensure the correct tools are called out and that no unexpected problems occur while accessing certain areas, and to look for any hidden “gotchas” throughout the maintenance activity. Such procedures “walk” the ground teams and the crew through every aspect of maintenance activities. The general flow of these procedures is to gather the needed tools and spare parts, turn off the power to the equipment, access the equipment being maintained, perform the maintenance, clean up and close out the workspace, and finally turn everything back on and ensure the hardware is functioning properly.

Some aspects of ISS maintenance are similar to the maintenance done at home, or in automotive or aircraft repair facilities. Crews use standard hand tools to remove bolts and other fasteners to access broken

components. They remove failed components and replace them with spare parts, then put the equipment back together using a torque wrench to ensure every fastener is tightened properly. In some instances, a good pair of pliers will help move a stubborn panel or a bent fastener. Given that astronauts all have varying degrees of experience in tools and maintenance, each crew member participates in maintenance training lessons that range from tool identification to performing complex maintenance operations on jet aircraft hardware. They also receive instruction on soldering, sewing, using a rivet gun, replacing Ethernet connectors, and creating wire jumpers and splices, not to mention the use of items such as a tap and die kit, driver drills and impact drills, and screw extraction kits.

The ISS is stocked with a wide variety of spare parts and tools because resupply from Earth is difficult, expensive, and time consuming. The tool inventory on board includes an array of hand tools, repair kits, and a number of specialty tools such as multimeters, pressure and temperature monitors, oscilloscopes, borescopes, and fiber optic diagnostic systems. Table 1 provides a summary of the maintenance tools and kits available for use in the US Segment of the ISS.

Maintenance and system upgrades on Earth often generate stories worth retelling, both when things go right and when things do not go quite as anticipated. What follows are a few of these stories to describe the implementation of some of the different types of maintenance performed on the space station.

**Table 1.** Summary of ISS Tools and Diagnostic Equipment for use in the Pressurized ISS Environment

In-Flight Maintenance Tools	Description
<b>ISS Toolbox</b> (Figure 1)	<p>A box of five sliding drawers that stores a majority of the ISS hand tools. The toolbox contains various sizes of wrenches, sockets, ratchets, torque wrenches, screwdrivers, pliers, L-wrenches, hammers, pry bars, files, tape measures, saws, feeler gauges, chisels, and punches. Many tools are available in both metric and standard sizes.</p> <p>Multiple sets of the commonly used tools are kept on the ISS to provide spares and to allow more than one crew member to use the same size/type of tool at the same time.</p>
<b>Power Tools</b>	<p>The handheld, battery-operated power tools on the ISS include driver drills, impact drivers, and the necessary drill bits, batteries, and chargers.</p>
<b>Repair Kits</b>	<p>The repair kits on the ISS include a generic parts kit that contains hose clamps, hose menders, hex nuts, zip ties, fasteners, countersunk screws, solid-state relays, switches, breadboards, potentiometers, capacitors, resistors, light-emitting diodes, transistors, diodes, circuit board fuses, cartridge fuses, knobs, tape, and foam.</p> <p>Additional repair kits include an Ethernet kit, soldering kit, wireway and coldplate covers, clamp and bracket kit with rivet gun, light-duty and heavy-duty sewing kits, screw extractor kit, and tap and die kit.</p>
<b>Electrical Tools</b>	<p>For electrical repairs, the ISS has a Scopemeter, which is a combination multimeter and oscilloscope, a current probe, a temperature probe, a pressure probe, a multimeter, and oscilloscopes.</p> <p>Two pin kits contain a number of wires of various gauges as well as pins and sockets to enable crew members to create their own jumper wires. These kits also have the various plugs and adapters needed for use with the Scopemeter and multimeter to take measurements on the ISS wiring.</p>
<b>Diagnostic Equipment</b>	<p>For troubleshooting and investigating maintenance problems, the ISS has diagnostic measurement software, a diagnostic power supply and accessories, a databus analyzer kit, Breakout Box, Multiplexer/DeMultiplexer On-Orbit Tester, electrical cable tester, fiber optic diagnostic and cleaning kits, and a fiberscope kit.</p>
<b>Fluid Servicing</b> (Figure 2)	<p>A Fluid System Servicer is used to drain and fill fluid lines inside the ISS. A fluid fitting torque device is used to mate and demate gamah-type fluid connections, which require very high torque to fully seal them. Fluid sampling tools are used to take and test fluid samples in the various internal thermal control loops.</p>
<b>Leak and Fire</b>	<p>Maintenance equipment will be needed in the cleanup after an overboard leak or a fire on the ISS. Kits to support that work include the ISS Leak Kit and the Post-Fire Cleanup Kit. The ISS Leak Kit contains patches for sealing small holes to vacuum in the pressure shell as well as the Ultrasonic Leak Detector to help the crew find the leak point. The Post-Fire Cleanup Kit includes the tools and adapters needed to clean combustion by-products out of the cabin air after a fire has been extinguished.</p>



**Figure 1.** The ISS toolbox in Node 1.



**Figure 2.** Shannon Walker with the Fluid System Servicer.



## “Can You See It Now?”

The Finding Ready to Latch section of the Structures and Mechanisms chapter provides details on the Centerline Berthing Camera System (CBCS). The heart of the CBCS is a video camera that looks through a hatch window at an incoming space station module or cargo vehicle. The camera view is important in ensuring precise alignment of the new module before it can be attached to the ISS. On Space Transportation System (STS)-102/ISS-5A.1 (2000), the CBCS video signal was to be sent to the aft flight deck of the orbiter to assist the shuttle crew in installing the Multi-Purpose Logistics Module (MPLM) for the first time. This would also be the first time the CBCS signal was sent from Node 1 through the newly installed US Laboratory, through Pressurized Mating Adapter (PMA)2, to a visiting orbiter (Space Shuttle Discovery, in this case).

The video monitor on the aft flight deck remained black after everything was connected and power was applied to the camera for a checkout on the day prior to MPLM installation. Thankfully, the CBCS checkout had been scheduled to occur the day prior to the MPLM installation, which gave the ground teams time to troubleshoot overnight. By the following morning, the crew had a fresh set of Diagnostic Maintenance procedures that could be used to pinpoint the source of the problem.

The crew first used one of the ISS laptops as a portable video monitor. With some spare cabling, the crew connected the laptop to the CBCS camera. This setup enabled crew

members to see the video and confirm the camera was functioning properly. For the CBCS to be fully operational, the camera needed to receive a return (sync) video signal from the orbiter. Yet, when the crew connected the laptop to the return line from the orbiter, no video was displayed, thereby indicating a video cable problem between Node 1 and the orbiter.

After ruling out any problem with the CBCS, the ground team looked at ISS video system drawings. It turned out that although PMA3 (used successfully with CBCS on STS-98/ISS-5A, months earlier) and PMA2 are nearly identical, the video wiring is not. The video and sync lines were inadvertently crossed on the PMA2 drawings. This cross wiring was dutifully implemented according to the drawings when PMA2 was built. This problem was not caught in ground testing because the testing did not use a setup that requires successful receipt of the video signal on the sync line, which is something the CBCS requires.

Once the problem was identified, developing a solution was simple. The video lines between Node 1 and the orbiter needed to be “uncrossed.” The crew created two jumper wires using the on-board pin kit, which is a collection of spare wire and electrical contacts (pins and sockets). These jumpers allowed the crew to cross the video and sync lines in the US Laboratory so that the wiring for the PMA2 would uncross it. This option was possible because the ISS wire bundles and harnesses have numerous connectors located throughout the spacecraft that are readily accessible to the crew. When

necessary, the crew can disconnect a wire bundle and use a connector to perform diagnostic troubleshooting on hardware or, in the case of the CBCS, correct an error in design and manufacturing.

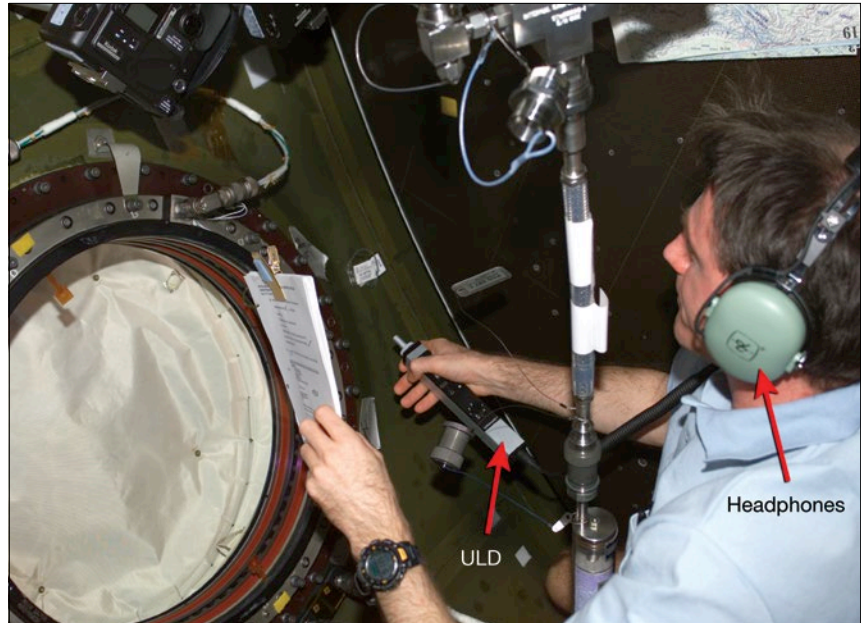
The result: Successful CBCS video was received on the flight deck in time to complete the first installation of an MPLM on the ISS. A more permanent jumper was manufactured and flown on STS-100/ISS-6A a few months later, and installed in place of the temporary pin kit jumpers. That jumper harness remained installed until Node 2 (Harmony) was installed on STS-120/ISS-10A (2007). Node 2 was built with crossed video wiring such that it would correct the wiring problem in PMA2 without the need for the extra jumper in the US Laboratory.

## “Where’s The Leak?”

Air leaks on a spacecraft are usually bad news because the air needs to stay inside for the crew to breathe. However, when an EVA (i.e., spacewalk) takes place, the airlock must be able to be depressurized to vacuum. When the normally pressurized airlock and its systems are at vacuum, there must also be certainty that no cabin air from elsewhere on the ISS leaks into the depressurized airlock. In the early years of the ISS, both types of “things you don’t want” occurred; i.e., a small leak of cabin air to space, and a small leak of cabin air into the airlock when it was at a lower pressure than the rest of the space station. In both cases, a diagnostic tool was required to help the crew find the source of the leak and stop it.

The new Joint Airlock, named Quest, was brought to the ISS on board STS-104/ISS-7A (2001). This proved to be an ambitious assembly mission. The first two of three EVAs to install the new ISS airlock were successfully conducted from the airlock of the Space Shuttle orbiter. The mission called for the final EVA to be conducted from the new airlock to prove that all airlock systems functioned correctly. A feature of the airlock design is that a depress pump can pump cabin air from the airlock back into Node 1. Instead of having to vent the cabin air overboard when depressurizing the airlock, and thus losing the valuable air resource, the air can be saved by putting it back in the ISS stack. This would only work as long as the hatch seal between Node 1 and the airlock did not leak. It also meant that the seals in the air lines between the depress pump and Node 1 could not leak; otherwise, cabin air would leak back from Node 1 into the airlock.

It was quickly discovered that a leak existed in the air lines when the depress pump was first turned on, thus allowing air from Node 1 to leak back into the airlock. This leak prevented crew members from being able to keep the airlock at the lower pressure they needed. Fortunately, a new diagnostic tool—an Ultrasonic Leak Detector (ULD)—was flown to the ISS on this mission. The ULD is a tool used widely in industry to find leaks in pressure vessels by converting the ultrasonic noise created by the leaking, turbulent gas into an audible sound. The more directly the microphone of the tool is pointed at the leak point, the louder



**Figure 3.** Expedition 8 Commander Mike Foale uses the Ultrasonic Leak Detector to try to pinpoint a small cabin leak to space near the window in the US Laboratory. A small probe is attached to the microphone of the ULD (near the astronaut's hand), which detects the ultrasonic noise of leaking air. That ultrasonic noise is converted to audible noise that the astronaut listens to in the headphones. The louder the noise, the closer the ULD probe is pointed toward the leak point.

the sound gets. The crew successfully used the ULD during the mission to locate a leaking fitting on the depress pump. The fitting was tightened and, ultimately, the final EVA of the mission was completed from the brand new airlock.

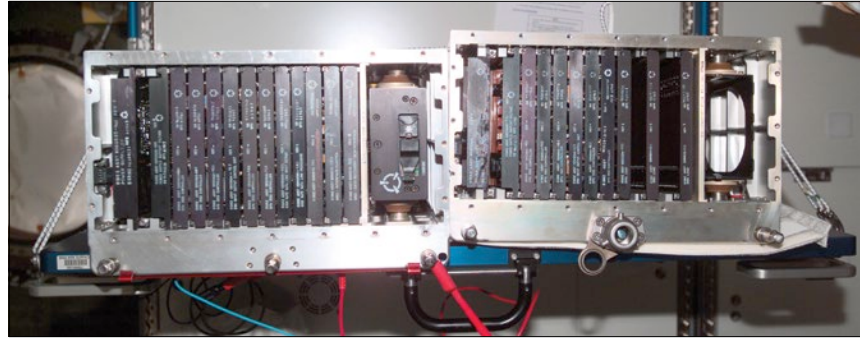
The primary reason for sending the ULD to the space station was to help the crew find leaks of cabin air to space. This method of using the ULD was first put to the test during Expedition 8 (2004). The ground teams detected a small leak (approximately 1.2 mm Hg [0.02 psi] pressure drop per day); however, the point of the leak could not be easily determined. The leak rate was slow enough that crew members did not need to perform

their emergency depressurization procedures; nonetheless, they did need to determine the source of the leak in order to stop it and prevent additional air from escaping. Over a number of weeks, the crew and the ground used the ULD and other techniques to isolate the leak to somewhere in the US Laboratory. The crew then used the ULD to survey the laboratory. The crew ultimately determined that the loudest source of ultrasonic noise was coming from a vacuum hose attached to the large window in that module (see Figure 21 in Chapter 3). The crew demated the hose from the vacuum source, which stopped the air from leaking.

## “That’ll Never Happen”

The computer systems on the ISS are divided into tiers (see Chapter 5). The Command and Control Multiplexer/DeMultiplexers (MDMs) make up the topmost tier. The three Command and Control computers, for redundancy, are always powered on. One is designated as the primary computer; the other two serve as backups. Prior to the STS-100/ISS-6A (2001) mission it was considered impossible—or, at least, non-credible—for all three of these computers to fail at the same time. If this were to happen, there would be nearly no way for the crew or the ground to interface with any of the other computers or space station systems.

During STS-100/ISS-6A, the impossible happened. One after another, all three computers failed. Fortuitously, this failure occurred while the Space Shuttle orbiter was docked. Since the orbiter had its own communication link with the ground, instructions could be voiced up to the ISS and orbiter crews to assist in recovering the computers. After some troubleshooting, the ground team determined that the only way to recover the system was to build new computers. The Payload MDMs are physically the same size as the Command and Control MDMs and use most of the same computer cards. Thus, one of the Payload MDMs was deemed a suitable Orbital Replacement Unit (ORU) to scavenge in order to build a new Command and Control MDM. Since the MDMs were not identical and did not have the same software load, the crew



**Figure 4.** The front cover of two MDMs are removed while the crew works to repair them during the STS-100/ISS-6A mission. The computer on the left is a Command and Control MDM, evidenced by the large black box of a hard drive in the right-hand bay of the MDM. The MDM on the right does not have the hard drive installed.

performed corrective maintenance to remove a Payload MDM, change some cards inside, and repurpose it as a Command and Control MDM.

The MDMs on the ISS were designed to be maintained at two different levels. The entire MDM ORU could be replaced. Or, the front face plate of the MDM could be removed, and individual computer cards or hard drives inside the MDM could be changed. A combination of both ORU-level and card-level maintenance was required to create the new Command and Control MDMs.

First, the backup Payload MDM, which is usually not powered when the primary Payload MDM is functional, was removed from its rack location in the US Laboratory. The front plate of that MDM was opened. Spare computer cards were inserted to change the internal card configuration to match the configuration of the Command and Control MDM. One of the spare cards was a hard drive that included the software needed for the MDM to

boot up. Once this new Command and Control MDM was installed, the ground was able to boot the newly constructed MDM into a diagnostic mode, which is similar to safe mode on a home personal computer. In this state, the ground slowly erased the payload operating software and loaded the data for the Command and Control software. Once all files of the new operating system were loaded, the flight controllers rebooted the machine and slowly recovered all the necessary software functions. With a single Command and Control MDM running, the crew completed additional IFM work to repair the other two Command and Control MDMs.

## “Give It a Whack”

For space station hardware to be strong and secure enough to survive the fairly rough ride into space and, at the same time, fit together well, designs usually require precise manufacturing and allow only small tolerances in the fit between

components. Ideally, everything would be fit checked on the ground prior to launch; however, this not always possible due to schedule, cost limitations, and the fact that many of the hardware pieces are built in different countries around the world. In addition to the standard conditions of their intended use, flight hardware must endure the vibrations of launch, the change in pressure as hardware goes from Earth pressure to vacuum (for hardware kept outside on the ISS), and the widely changing thermal environment in Earth orbit. The thermal environment especially affects hardware located outside the space station, as that environment fluctuates with each orbit as well as with each season.

Despite the best maintenance approaches and planning, as well as the best hardware design, two pieces of hardware can get stuck together and need to be separated. As sometimes happens when conducting repair work on Earth, the two pieces may need nothing more than a slight tap or even a good whack. Due to the cost of equipment on the ISS, this is usually an option of last resort.

The need for a tap or a whack has played out a number of times on the ISS. On multiple occasions, hardware inside the space station needed some extra hammer taps to be convinced to come free from mounting locations they had occupied since launch. The same is true for hardware outside the space station. During an EVA in Expedition 6 (2003), astronauts Ken Bowersox and Don Pettit needed to move a light stanchion, or post, that was mounted to the ISS truss. The stanchion was held in place by a single bolt, and it sat in a type of

tongue-and-groove interface on the truss. After the bolt was released, the stanchion refused to come free from the truss. After the astronauts tried multiple ways of wiggling and shaking to free the stanchion, it was decided to abandon the stanchion until the next EVA so that the ground team could come up with additional options and recommendations.

After much discussion between the engineering and flight control teams on the ground, it was decided that the best option for the second EVA, if renewed wiggling and shaking did not work, was to use a hammer to tap the stanchion free. After a few small taps did not free the stanchion, the crew gave the stanchion a more reasonable “whack,” and the stanchion came loose.

The STS-114/ISS-LF1 (2005) mission was the Return to Flight for the Space Shuttle Program after the loss of the Space Shuttle Columbia. This mission brought the MPLM to the space station to provide some much needed cargo resupply. The MPLM is a full-sized ISS module, flown up in the Space Shuttle cargo bay, and attached to one of the ISS Node modules. Once the MPLM was attached on this mission, the crew was ready to open its hatch and start transferring supplies.

As happens with most new modules that are brought to the ISS, once power is available to the module, the internal fans are turned on to circulate the air within the module before the hatch is open. This draws any free-floating debris to the air filters so the crew members do not breathe in the debris or get any in their eyes when they enter the

module for the first time. This air motion can generate a slight increase in pressure inside the module, which will effectively push the hatch closed. Given the large size of the hatches, even a small pressure differential across a hatch can create a large pressure force pushing the hatch against its seals, which would prevent the crew from being able to open the hatch. For example, a pressure differential of 0.98 mm Hg (0.019 psi) pushing the hatch closed will require the crew to put 220 N (50 lb) of force into the hatch handle to overcome the pressure. When the external side of a hatch is exposed to space vacuum, approximately 173,500 N (39,000 lb) of force press the hatch against the bulkhead seals.

Hatch designers thought of this, of course, when the hatches were designed. All hatches have valves that crews open to allow the pressure on both sides of the hatch to equalize. Thus, to open any hatch on the space station, the crew must first open the equalization valve and wait for the pressures to balance.

On STS-114/ISS-LF1, crew members opened the equalization valve and waited the appropriate amount of time to equalize the MPLM pressure with the ISS pressure. When they tried to open the hatch, it would not budge. As described in the “Hatches” section of Chapter 3, the hatch mechanism contains “kickers” that push against the bulkhead of the module when the crew turns the hatch handle. These kickers help crew members unseat the hatch. Even though crew members put extra force into the hatch handle to try to get these kickers to push harder against the bulkhead, the hatch would not open.

## When The Nearest Handyman is You

*Colonel Timothy Kopra, Expeditions 20 and 46/47*

The ISS is a world-class orbiting laboratory. Every day, the crew members on board conduct a variety of experiments that will help us prepare for going out beyond Earth's orbit, discovering fundamental aspects of science, and improving life on Earth. The space station is an amazing place to work and live, but the environment we have is only what we have created and maintained. Outside of the station's thin aluminum hull is a vacuum that is completely inhospitable to life. It is so vital, then, that we maintain and sometimes repair the systems on board that provide our clean atmosphere, water, electricity, thermal control, and communications, just to name a few.

One of the key components of our life support system on the space station is the Carbon Dioxide Removal Assembly (CDRA). After we extract the oxygen that our body needs when we inhale, we exhale a significant amount of carbon dioxide (CO<sub>2</sub>). Each person exhales around 20 liters (5 gallons) per hour, for a total of 120 liters (32 gallons) per hour introduced into our atmosphere when there is a crew of six on board. Humans are very sensitive to even low amounts of CO<sub>2</sub> when we breathe it in. Just a fraction of 1% of CO<sub>2</sub> in the air can give you a headache, cause fatigue, and affect how clearly you think.

The primary CDRA installed in Node 3 failed in February 2016, when the fan motor controller malfunctioned. This device controls the operation of the blower that provides airflow through the CDRA. The task of replacing the motor controller was a bit like removing the engine from a small car and then replacing some of the components attached to it. The CDRA was located in a rack about the size of a large refrigerator behind some panels. It is tightly installed within the rack and connected to other parts of the system. After removing the panels to get access to the CDRA, Scott Kelly and I followed the well-crafted procedures developed by the ground maintenance team to slide the CDRA out, disconnect it, and remove it from the rack. After this, we were able to get to work on the repair.

We floated the large CDRA through the station to a maintenance work area (our workbench), located in Node 2. While zero gravity makes it easy to move around a large piece of hardware such as the CDRA, it can be a bit tricky to secure it and set it up for maintenance. We used a set of bungee cords on the maintenance work area to keep the CDRA in place while still providing access for the maintenance tasks.

Since considerable time is dedicated to removing a CDRA, the ground team decided that we should also replace some other parts that were not in top working order. We were tasked with replacing a heater controller and one of CDRA's valves as well as the motor controller. Earlier in the morning, we had collected the spare components and all of the tools that we needed for removing and replacing each part. The rest of the job was pretty straightforward: Scott and I worked together to replace the failed components using the procedures that described in detail which tools to use and the steps to remove the components and install the new ones. After the removal and replacements were complete, we worked in reverse, floating the CDRA back to Node 3, installing it back into the rack, and reattaching the panels. We then waited with anticipation as the ground team performed the activation steps to make sure it all worked. We were glad to hear the call from Mission Control that the Node 3 CDRA was again up and running.

One lesson that this relatively routine maintenance task highlights for me is how important it has been for us to have a highly functioning team to keep the ISS operational every day. Teams of experts on the ground have the in-depth knowledge of all of the systems and hardware on board, and they are the ones who identify the failures that occur, develop the thorough and clear procedures, train us to make the repairs, and manifest the replacement parts and tools for maintenance. We have a team of teams that keep our space station flying, and they frankly do such an outstanding job that they make it look easy. And it certainly is not.



**Figure 5.** Expedition 11 Commander Sergei Krikalev and STS-114/ISS-LF1 Mission Specialist Wendy Lawrence prepare for opening the MPLM hatch in 2005. Their initial attempts would not be successful. Ultimately, a well-positioned shove would be required to open the hatch.

Ground controllers in Houston struggled to come up with another option as all the standard “tricks” were not working. With everything the crew and ground had tried, the hatch should have opened easily at this point. The ground teams talked about the possibility that the MPLM hatch may not open at all, and what the impacts to the mission might be in that scenario. As Mission Control talked to the crew about possible options, the flight control team heard a muffled “oomph” in the background, followed by a cheer from the crew. The hatch had opened. The trick that worked? One of the taller astronauts stood on the hatch ribs and then crouched while reaching up to an overhead footbridge. He straightened his body and pushed hard against the Node 1 footbridge. Effectively, he put all his weight into the hatch and forced the hatch open. The mission could continue as planned.

Later, engineers speculated that the small space between the two hatch seal beads had a lower pressure than the space station cabin—possibly even a vacuum. This lower pressure, due to the large hatch size, was effectively “sucking” the hatch against the MPLM bulkhead until enough force could be put into the hatch to overcome this pressure force.

Sometimes, when it comes to getting hardware to work correctly in the extreme environments away from Earth—despite the best designs and pre-laid plans to resolve problems—a good tap, nudge, whack, or shove may ultimately do the trick.

## The Mod Kit

Short for “modification kit,” a mod kit is a collection of equipment that needs to be installed on the ISS (usually inside, but sometimes outside, as well) to accommodate new hardware or new functions on the spacecraft. Mod kits can be small in size, or they can be quite large and complex. The need to install a mod kit usually presents a relatively rare opportunity to renovate and/or remodel the space station. Installation of a mod kit often requires the use of the many different maintenance techniques mentioned in this chapter.

An example of a relatively small mod kit was the transition away from a large, single ORU in the urine processor that both filtered and stored pretreated urine. The large, single tank was being disposed of when the urine container was at its end of life, even though the filters (which were contained inside the tank) still had a much longer life available. The mod kit replaced this single component with a number of smaller, individual filters and a separate urine containment tank. The new design allowed for each subcomponent to be used until it had reached its own end of life. The mod kit contained the various separate filters, urine tank, and hoses to connect them all together. In this case, the OSO flight controller’s job was to determine how to best install the new hardware to make sure it would all fit inside the rack that was designed and built to accommodate the single, larger ORU.

An example of a much larger mod kit is the project to reconfigure the ISS to support the Commercial Crew Program. This renovation requires the relocation of the Permanent Multipurpose Module and PMA3 module, installation of new docking adapters and control panels to operate them, and installation of new equipment so the ISS can communicate with the new commercial crew vehicles. New power and data lines will run throughout the US Segment to connect the new hardware, and to ensure full functionality of the modules that were relocated. A number of software changes on the ISS are also required to ensure the ISS MDMs know how to communicate with and control the new and reconfigured equipment.

A number of mod kits are involved in this US Segment reconfiguration. Planning and coordinating the implementation of this major rearrangement is being done across all of the flight control disciplines, the ISS Program, engineering organizations, and the various ISS Program contractors. The mod kit components and hardware will not all arrive at the ISS at the same time. They will launch to the ISS over a span of a number of years. Thus, choreography of what can be installed or relocated is as important as developing the maintenance procedures to actually perform the work. The first mod kit installation on the ISS for this effort occurred in January 2015, and completion is expected in time

to support the first docking of a commercial crew vehicle in 2018. This major renovation work is also choreographed to ensure that the ISS and its crew can remain focused on the primary ISS mission of performing as much research and scientific investigation as possible.

## Conclusion

Maintenance is a key factor in keeping the space station fully functional to support not only the life and livelihood of its crew but also its primary mission of unique off-Earth scientific research. Maintenance comes in a wide variety of forms, from simple cleaning and hardware replacement to intricate diagnostics and component repair. Repairs have proven successful through prepositioning supplies, detailed pre-launch training, and teamwork between the ground and crew. Often, adaptability and ingenuity has been required for problems that were not always anticipated. A copious supply of tape and resourcefulness from all involved has also proven to be a key factor, and will undoubtedly remain so for the rest of the space station program.





# Chapter 17 **Systems:** Extravehicular Activities—Building a Space Station



*Astronaut Mike Hopkins participates in the second of two US spacewalks to change out a faulty external pump on the International Space Station (ISS). Visible in his helmet visor are Rick Mastracchio (Hopkins' partner on the spacewalk), the ISS robotic arm, and some ISS structure and solar arrays. Dec. 24, 2013.*

**Something about seeing an astronaut in a spacesuit captures the imagination of children and adults alike.** Perhaps the human shape of the spacesuit against the backdrop of Earth gives one a sense of human fragility, or maybe looking at the suit is a little like glimpsing at

a futuristic human race. The general public can tell just by looking at a photo that “walking” in space while attached to the vehicle by a tenuous lifeline is one of the most dangerous pursuits. A spacewalker wears a personal spacecraft that must provide protection from the freezing cold of

space, the burning heat of the sun, and the small pieces of space debris that could come hurtling at him or her at thousands of miles per hour. The reality is that astronauts and Mission Control are hyperaware of such dangers during a spacewalk.

## The Foundation for International Space Station Spacewalks

Spacewalks—or extravehicular activities (EVAs)—performed on the International Space Station (ISS) evolved from a rich history of spacewalk experience starting in 1965 with the first Soviet and American spacewalks and continuing through subsequent human space programs. Spacewalks continued to evolve when the ISS came along since building the station required an unprecedented number of EVAs. The ISS is almost four times as large as the Russian space station Mir and about five times as large as the US Skylab, with a design that demanded a lot of manual bolting together of components and hand-mated connections.

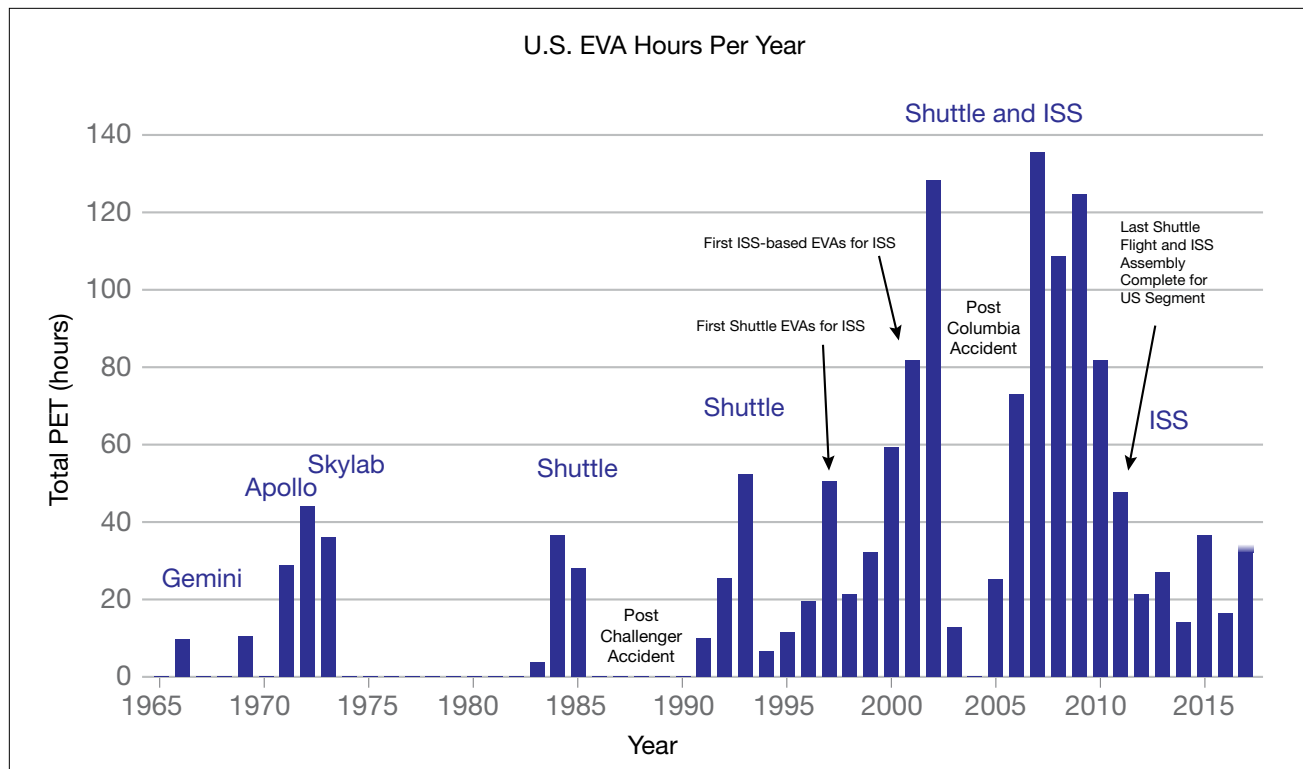
As the timeline for construction of the ISS approached, EVA teams looked at the daunting task of assembly as the “Wall of EVA” (Figure 1) since the amount of EVA time would rise rapidly compared to prior years. As of Expedition 51 in 2017, astronauts had completed more than 1243 EVA hours in 191 EVAs for the ISS, including 28 Space Shuttle-based EVAs. Astronauts and cosmonauts conducted roughly 80% of ISS EVAs in US spacesuits, and the rest were conducted in Russian spacesuits out of a Russian airlock.

For comparison of the US programs, the Gemini Program conducted nine EVAs (the first of which was only 20 minutes long, compared to today’s standard planning of 6+ hours per EVA), the Apollo Program conducted five spacewalks and 21 lunar

“moonwalks,” and Skylab conducted 10 EVAs. Prior to ISS assembly, astronauts conducted 41 EVAs during Space Shuttle flights over the course of 15 years.

Looking back now at the Wall of EVA, NASA’s expectations were right on the money. These spacewalk-heavy years were extremely intense and challenging for the Space Shuttle and ISS teams. But these years were also incredibly rewarding, with the creation and growth of the space station occurring one EVA at a time.

The Space Shuttle Program provided the major basis for US EVA hardware and techniques for the ISS since the shuttle was bringing up the United States On-orbit Segment elements for installation and assembly. Furthermore, the US Segment was



**Figure 1.** US EVAs over the course of NASA’s history through mid 2017. The Wall of EVA hours looked daunting to the EVA teams as the ISS Program approached.



**Figure 2.** Astronaut Mark Lee tests the nitrogen-propelled backpack that would be needed for the ISS. Space Shuttle mission STS-64 (September 1994).

built largely by shuttle crews that wore shuttle spacesuits.

During the ISS design development, NASA conducted specific Space Shuttle EVA experiments to determine acceptable ways to assemble a space station and

understand new requirements for EVA equipment. This process included testing designs for assembling a truss structure and new EVA tools for an extravehicular crew member who had to maneuver around a large ISS structure. Although all ISS EVAs include

having the crew member tethered by lifeline to its structure, shuttle crews tested a nitrogen-propelled backpack flown by extravehicular crew members using a joystick (Figure 2). This backpack—called Simplified Aid for EVA Rescue (SAFER)—can be used in case an

astronaut “falls off” of the ISS since the space station is not able to chase after a lost crew member as the Space Shuttle theoretically could have done.

The focus of this chapter is on US spacewalks using the US spacesuit, which is called the Extravehicular Mobility Unit (EMU). However, Russian EVAs (using the Orlan spacesuit out of a Russian Segment airlock) have also contributed greatly to the construction and maintenance of the ISS. US EVA experts spent a number of years during early ISS construction temporarily living in Moscow to work with Russian EVA experts for the purpose of negotiating crew training, spacewalk techniques, and hardware use. Spacewalks have been conducted by Americans in Orlan and Russians in EMUs (plus other international partners in both suits), and training has been conducted in both countries in both spacesuits. In fact, early in the program, it was envisioned that the US Segment airlock would be used for both Orlan and EMU EVAs. The airlock was built accordingly to accommodate both suits. The airlock Quest on the US Segment is called the Joint Airlock for that reason. However, having Orlan operations on the US Segment has not been needed as much as anticipated, and Russian Segment tasks are closer to the Russian airlock. Therefore, some of the equipment that the Joint Airlock would require for an Orlan EVA was not launched for installation in the airlock (notably, the Orlan umbilicals needed for oxygen, cooling, power, and communication while the crew member was still in the airlock). All Orlan EVAs have been executed out of Russian Segment airlocks, to date.

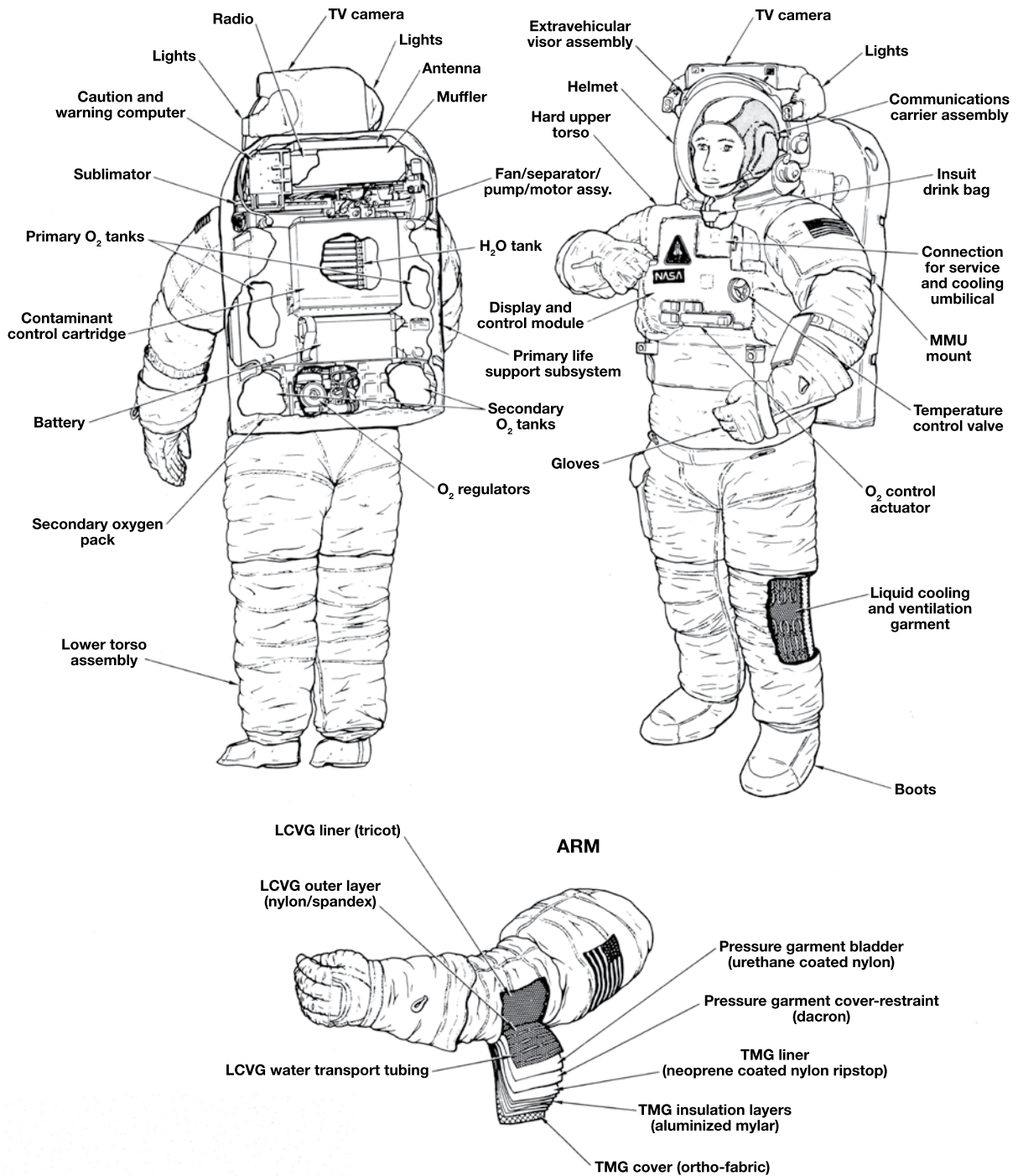
## The US Spacesuit

The iconic white US spacesuit has to provide the functions of a spacecraft while being wearable. Its design is mostly unchanged from the Space Shuttle Program, although some features and components evolved during ISS operations. For example, the Space Shuttle EMUs were designed to be used for the short duration of a shuttle mission—i.e., no more than a handful of EVAs—and returned to Earth for servicing before use on a subsequent flight. It was desirable to leave the EMUs on the station for longer periods of time since launching bulky spacesuits over and over to the ISS is expensive and would mean other things couldn't be launched in their place. The spacesuit contractor extended the life of EMUs by replacing some parts and testing others for longer life to enable them to remain on orbit for several years without periodic ground checks. Another upgrade was to toughen some of the material on the gloves. Astronauts use their hands to maneuver around the ISS, thus the glove material had to be strengthened to withstand extended wear and provide more protection against the sharp edges that develop on the exterior of the station over time. Although almost all of the external hardware is manufactured to have smooth edges, Micrometeoroid and Orbital Debris (MMOD) strikes on the ISS surface over the years have produced various cuts and protrusions in the metal handholds and on other surfaces. The material upgrade was made after the crew discovered a number of cuts in the outer layer of the gloves following EVAs.

The EMU (Figure 3) provides the fundamental needs for a crew member on a spacewalk lasting approximately 6.5 hours. It provides pressure and an oxygenated atmosphere, environmental protection from extreme temperatures/radiation/some space debris, mobility, and communications. Sometimes, the EMU can provide these fundamental needs for more than 6.5 hours, depending on the thermal environment, specific crew member metabolic rate (which determines how much oxygen he or she breathes and how much carbon dioxide is produced), and the difficulty or workload for a given EVA. In addition to the expected 6.5 hours, the suit allows the team to manage 30 minutes of additional capability (e.g., oxygen and other consumables, such as battery power, that are used during an EVA) as pure margin to ensure the crew member gets back inside the station before critical supplies run out.

The EMU breathing environment during an EVA is pure oxygen at 217 millimeters of mercury (mm Hg) (4.3 pounds per square inch [psi]), which is equivalent to approximately 9 km (30,000 ft) altitude simply in terms of pressure. This environment was originally chosen based on historical knowledge of pressure suit systems, and it accommodated several competing requirements for Space Shuttle EVAs. A spacesuit needs a strong pressure bladder to retain the atmosphere, as well as restraining material to conform the suit to a human and hand shape. Lower pressure is necessary to allow for the mobility required to grasp tools and move around the structure while working inside the bladder and restraints. Even at

**Extravehicular Mobility Unit**



**Figure 3.** The major components that make up the EMU.

217 mm Hg (4.3 psi), working in the suit can be fatiguing, especially for a crew member's hands. At pressures this low, air does not supply the necessary quantity of breathing oxygen, hence the pure oxygen atmosphere. The lowest allowable oxygen pressure in which humans can operate safely is approximately 160 mm Hg (3.1 psi). However, a pressure that low does not allow any margin for suit leaks or normal variation in system components. Very low suit pressure also increases the risk that the crew member will develop decompression sickness (DCS)—i.e., “the bends” that scuba divers work to avoid. Therefore, the EMU pressure of 217 mm Hg (4.3 psi) was selected in a balance of these factors.

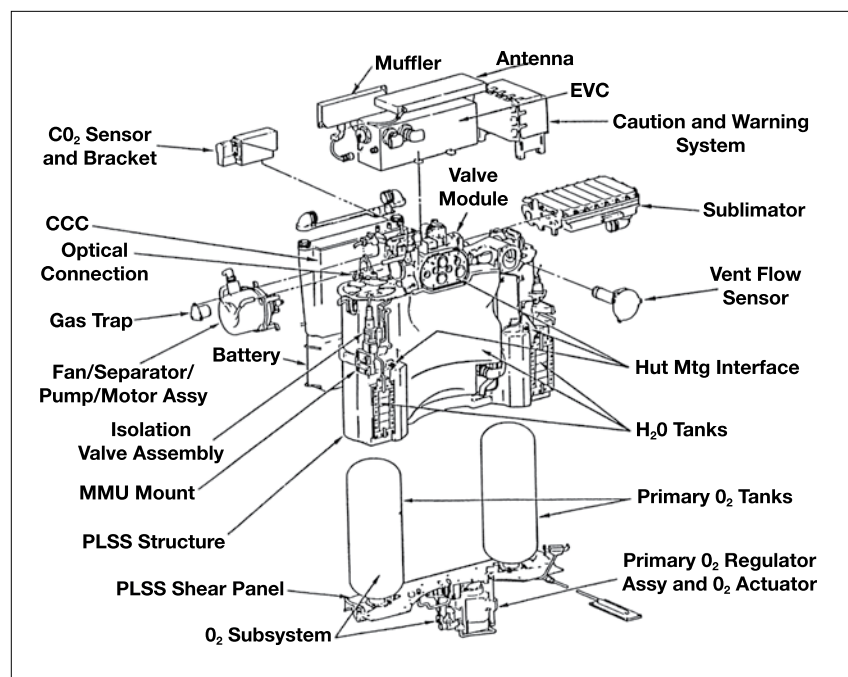
Oxygen is supplied by the primary oxygen supply tanks (~44000 mm Hg [850 psi]). Or, if needed, oxygen can be supplied by the Secondary Oxygen Package (SOP) tanks (~258,000-310,000 mm Hg [5000-6000 psi]). The pressure regulation system uses the primary oxygen exclusively on an EVA unless the pressure in the suit drops to approximately 201 mm Hg (3.9 psi) due to primary oxygen depletion or a leak in the suit. At that point, the SOP will “come on line” to keep the suit pressure around 201 mm Hg (3.9 psi). The SOP tanks are sized to provide enough oxygen to keep the suit pressurized while the crew member quickly translates back to the airlock in the case of a small leak, and also for potential failures that would require the crew member to “purge” the suit by intentionally opening one of two small holes to allow gas to flow out. Purging might be needed if, for example, the fan

shuts down and dangerous levels of exhaled carbon dioxide start to accumulate in the helmet. In these cases, the primary oxygen tanks will become depleted faster, requiring the SOP to provide the necessary make-up oxygen to allow the crew member enough time to reenter the airlock.

During an EVA, a fan circulates the oxygen, and the crew generates carbon dioxide, heat, humidity, and other contaminants. The flow is forced through a Contaminant Control Cartridge (CCC), which is a replaceable container that “scrubs” (i.e., removes) carbon dioxide and other contaminants from the gas environment. The CCC contains filters and charcoal to remove contaminants and odor, and either heritage Space Shuttle-based lithium hydroxide (LiOH) or ISS-based metal oxide (Metox). The LiOH or Metox removes carbon dioxide through a

chemical reaction, introducing heat and water vapor into the oxygen flow. After the flow is cooled and humidity is condensed out, the newly scrubbed oxygen combines with fresh oxygen from the primary system and is introduced to the crew member's helmet, blowing over the face. The CCC is changed out prior to each EVA. LiOH cartridges are used only one time, whereas Metox is a regenerable cartridge that was created for ISS use and can be reused on a subsequent EVA after the carbon dioxide is removed using a specialized heating system in the airlock (Figure 4).

Temperatures in low-Earth orbit reach extremes of approximately -93°C to +149°C (-200°F to +300°F). The EMU keeps the crew member comfortable, although he or she can get too hot or cold depending on a variety of situations. Factors include



**Figure 4.** Some key life support system components in the backpack of the EMU.

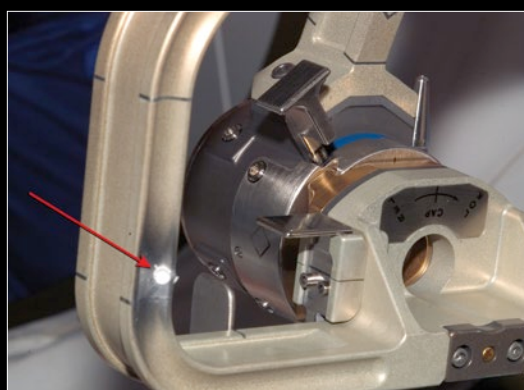
Credit: "Suited for Spacewalking: An Activity Guide for Technology Education, Mathematics, and Science, EG-1998-03-112-HQ."

## Micrometeoroid and Orbital Debris

Spacecraft in orbit around the Earth encounter small fragments of rock called micrometeoroids (as opposed to meteorites, which are larger pieces of rock that survive reentry into Earth's atmosphere). Orbiting spacecraft also encounter a growing amount of debris such as rocket bodies and pieces of spacecraft that have exploded. Collectively, these particles are called MMOD. The entire ISS must be maneuvered to dodge larger pieces that could slam into the station and create a large hole in the structure. However, the ISS is constantly exposed to tiny particles that are too small to track from the ground (Figure 5). This issue is discussed, in greater detail, in Chapter 8.

Partway through the ISS assembly, serious cuts in the EMU gloves were seen, which caused alarm within the EVA community. ISS EVAs were already rough on an astronaut's gloves due to connector manipulation and moving long distances, but crews also started pointing out and photographing more and more MMOD strikes on the ISS that could be contributing factors. When a piece of debris strikes the ISS, it can leave a small pit or hole with sharp points that could tear an EMU glove (Figure 6). Initially, the crew was told to mark an MMOD strike with a wire tie (i.e., a few inches of wire similar to a coat hanger) by wrapping it around the handrail as a visual indication to the next astronaut. However, the strikes became too numerous. Crew members are now given a briefing where they view several photos that show the many known MMOD strikes. The message to the crew: Look before touching. Each time an astronaut performs an EVA, a new strike might have happened since the last EVA. The EMU glove materials were upgraded to be more durable, but the gloves are still carefully photographed and inspected after each EVA. Tethers—a crew member's lifeline to the ISS—are also inspected for MMOD strikes before reuse.

Depending on the EVA, the calculated odds are approximately 1 in 8000 that an EVA crew member's spacesuit will be struck by MMOD during that EVA, although the strike would have to create a hole approximately 4 mm (0.2 in.) or larger to be fatal. The odds that any crew member, inside the ISS or performing an EVA, will not survive because of an MMOD strike to the ISS are around 1 in 120 over a 6-month period, since a hurtling piece of debris could puncture a pressurized module and cause rapid depressurization that is too fast to allow astronauts or equipment to react.



**Figure 5.** Two views of an MMOD strike on a tool that had been on the ISS exterior, exposed to the elements. The crew found this crater during Space Shuttle mission STS-123/ISS-1J/A.



Although a lot of the outer-most material is missing, the hole in the fabric is the area of greatest concern.

**Figure 6.** Glove tears that were noted during an EVA on STS-118/ISS 13A.1, causing the flight control team to terminate the EVA (i.e., bring the crew member back into the airlock early) as a preventative measure. Fortunately, the bladder that holds in the oxygen and keeps pressure on the astronaut was not damaged. Only the outer layers and fabric were affected.





**Figure 7.** An LCVG, with its small water-filled tubes throughout and larger yellow ventilation ducts on the shoulders, floats in the airlock. The water tubes and ventilation ducting come together at the right waist with a connection point to the spacesuit. The fan/pump/water separator in the suit's backpack (not shown) provides the circulation. Shoulder pads provide a cushion from hard points in the suit and help fill some volume for an overall snug and comfortable fit.

whether the crew member is shaded from direct sunlight, whether the tool or the contact surface tends to absorb or reflect heat, and the crew member's activity level relative to the cooling system of the suit. Cooling is performed both passively and actively. Passive thermal control and radiation protection is provided by the outer suit layers that reflect sunlight and provide insulation. Active cooling removes generated and absorbed heat via a circulating water system with

a component called the sublimator. Tanks supply water to form a sheet of ice on the sublimator, which is exposed to the vacuum of space. In a vacuum, the ice sublimates (i.e., transitions directly from a solid to the gas phase without going through the liquid phase), removing heat as part of the process. Oxygen that is being circulated through the CCC and fan passes through the sublimator to provide cooling of the circulating gas and to condense out excess humidity.

Water is circulated over the crew member's body via the Liquid Cooling and Ventilation Garment (LCVG), which is an internal bodysuit with approximately 91 m (300 ft) of thin flexible tubing sewn into the fabric. Ventilation ducting provides oxygen circulation in the arms and legs of the suit, thus the gas in those areas is also cleansed and dehumidified (Figure 7).

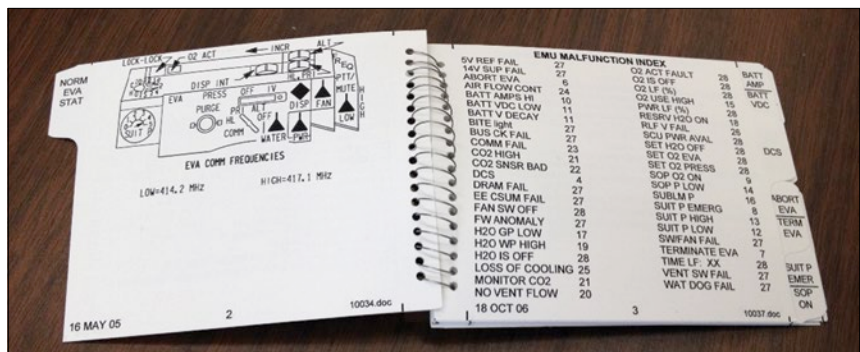
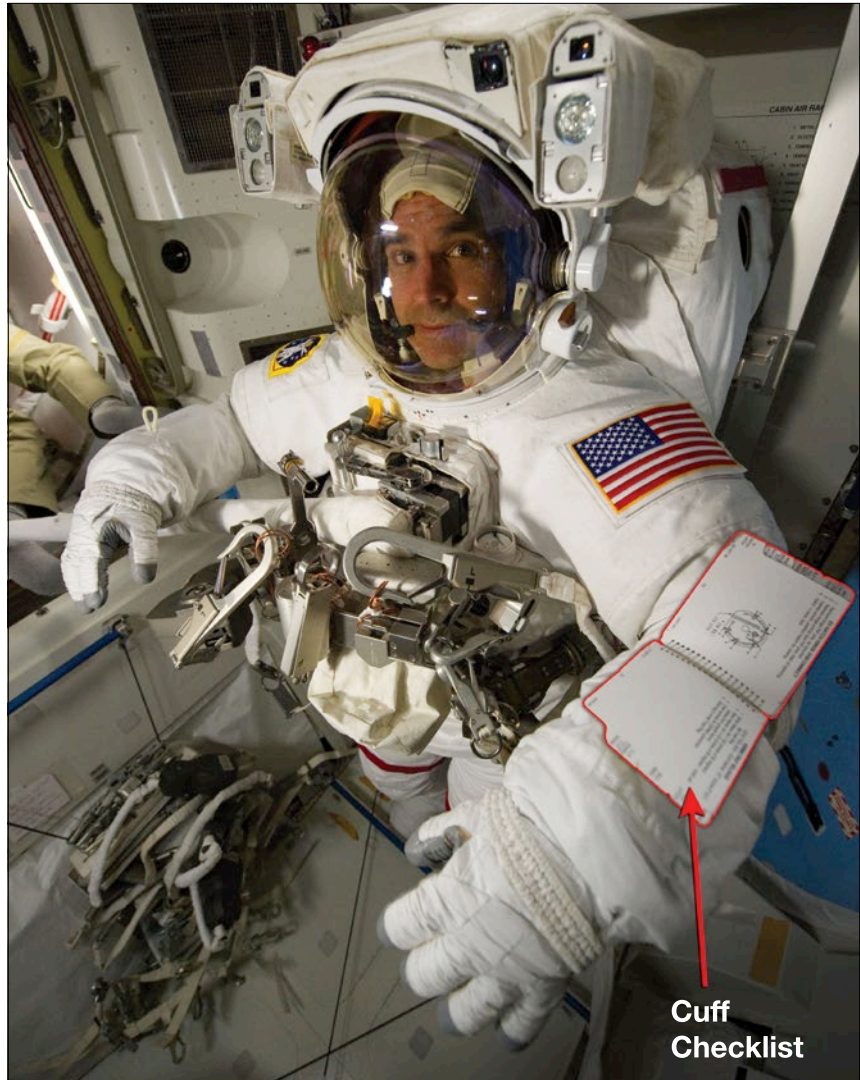
In addition to providing thermal control, the carefully crafted multiple-layer composition of the suit is a stack of nylon, insulation, and fabric. Its design holds in the pressure, restrains the suit to conform to the body, and provides some protection from suit leaks due to small MMOD hits or punctures from tools or sharp objects on the ISS. The outer garment protects the internal pressure bladder (i.e., coated nylon "balloon" that keeps the pressure in) with materials that help protect against abrasion, puncture, and damage propagation. In other words, the design intention is such that a small hole is less likely to become a huge rip as the crew member moves around in the suit.

Communication with other spacewalkers, the ISS, and the ground occurs through an ultra-high frequency (UHF) radio system, at a frequency that is lower than that used in car alarm systems and walkie-talkies (see Chapter 13). UHF antennas are located in the airlock and on the outside of the space station to transmit communication and some EMU status information to the ISS. That information is relayed to the ground through the standard space station communication system. Each EMU has a primary radio and a backup radio (as does the UHF system

on the ISS) to ensure communications are not lost. Crew members wear a communication cap (i.e., a “Snoopy” cap) with a microphone boom. The microphone is set to transmit without requiring the crew member to push a button on the suit. Everything he or she says can be heard, assuming the communication links are good. Each crew member’s electrocardiogram data are also transmitted over UHF so that flight surgeons in Mission Control can monitor the health of each astronaut during the activities. EVAs are strenuous. Prevention of a serious health issue is critical since treatment is difficult, if not impossible, until the crew member is back inside the space station.

The Display and Control Module is the brains of the suit and includes a Liquid Crystal Display readout, switches, and a pressure gauge. The crew display is somewhat similar to a car or cockpit’s computer readout system. It gives the crew member insight into the health of his or her suit, including audible alarms through the Snoopy cap, when required. Since a crew member can’t see the front of his or her chest when in the suit, a wrist mirror is used to look at the controls on the front of the suit, which is why the labeling is backward. The Cuff Checklist—a small binder attached to the crew member’s wrist—contains reference instructions and emergency procedures (Figure 8).

The EMU is sized for each crew member through a modular approach, with various sizes and lengths for the main torso and other parts. Fit is further improved with sizing spacers and fine adjustment tabs in the suit, although EMUs are still notoriously



**Figure 8.** The EVA Cuff Checklist (bottom) is a small book worn on the wrist (top) that the crew can reference for steps to perform during normal operations and in emergency situations. The crew often prints out new pages sent from Mission Control Center or writes on blank pages with some additional reminders just before an EVA.

Photo credit: NASA/Dina Contella



**Figure 9.** EMU components are specifically picked out for each crew member so the suit can be appropriately sized. Shown are: (left) the Lower Torso Assembly, with boots and metal sizing rings pictured; (center) an EMU glove; and (right) a sizing ring for lengthening an arm.

difficult to size perfectly (Figure 9). Crew members often have their own gloves made to fit their hands, or they use another crew member's gloves if they are a good approximation and available for their flight. The spacesuits cannot stay on orbit indefinitely, and there is not enough storage space to accommodate multiple sets of every sized piece. Thus, ground teams work on EMU logistics to ensure the various parts, including spares, get launched and are on orbit for each crew member. Wrinkles in these complicated logistics can occur, as was the case in the destruction of the Cygnus cargo vehicle on October 28, 2014, when the rocket carrying Cygnus exploded shortly after liftoff (Chapter 14). The cargo mission was carrying EMU equipment, including a sized LCVG for one crew member, as well as a SAFER unit and several tools and suit maintenance items that had to be sent up on a later mission. A SpaceX cargo vehicle was also lost during launch on June 28, 2015, resulting in the loss of an EMU life support system and upper torso that was being sent up for its freshly refurbished parts.

The EMU offers quite a bit of functionality, considering its small size as a spacecraft. It has a rechargeable battery for powering the various components when out on an EVA. A crew member can pull down a sun visor on the front of his or her helmet to act as sunglasses when orbital night turns into brilliant orbital day approximately every 90 minutes (a sunrise or sunset occurs approximately every 45 minutes). Helmet lights are used for operations at night, and a television camera is mounted to the helmet so the ISS crew inside and the flight controllers on the ground can monitor the extravehicular crew's activities. Crew physiology support includes a drink bag with a straw and a maximum absorbency garment (i.e., a diaper). After an incident where water entered a crew member's helmet on US EVA 23, NASA equipped the EMU with a helmet absorption pad to absorb water on the head, as well as a snorkel similar to those used by scuba divers. The snorkel extends from near the mouth down to the waist so the astronaut can breathe oxygen from the body of the suit if the helmet fills with water.

The Orlan (Figure 10) provides similar capability but is packaged differently. Example differences include rear entry through a hatch for quick self-donning instead of the EMU shirt-and-pants design, adjustable length sizing rather than modular parts, and a higher operating pressure (295 mm Hg [5.7 psi]).



**Figure 10.** US astronaut Mike Fincke is working in a Russian Orlan spacesuit. Some US tools were used during this EVA, with adapters installed as needed so they could be used with the Orlan.

## US Extravehicular Activity 23 Water-in-Helmet Incident

During US EVA 23 on July 16, 2013, water entered astronaut Luca Parmitano's helmet about an hour into the EVA. The crew, flight control team, and engineers on the ground did not understand the source of the water and initially thought it may have come from a leak in the drink bag. However, the increasing quantity and unknown source caused the flight control team to call for an early termination of the EVA. Parmitano started translating back to the airlock. On the way, the water migrated to his face, covering his eyes, ears, and nose. Since there was no gravity to pull the water away from his nose and mouth, he could potentially drown in space. His vision and communications were degraded, and he had to use his safety tether as a guide to get into the airlock. Both crew members made it back into the airlock. Via a series of hand squeezes, Chris Cassidy (the other crew member) confirmed Parmitano was okay while they performed an airlock repress and suit doffing. After the EVA, the crew reported approximately 1.5 liters (0.4 gallons) of water in Parmitano's helmet. This quantity matched the amount that was later determined to be missing from the water tanks that fed the sublimator during the EVA. Looking back, it was clear that Parmitano nearly drowned in the suit, and that the quick actions taken by the crew and ground team saved his life.

Prior to this incident, crew procedures did not mention what to do if this quantity of water was in the helmet.

This is because spacesuit testing on Earth showed that the fan would shut down and the water system would close off if a large quantity of water entered the ventilation system. However, in a zero-gravity environment, water can form a thin layer on the wall of the fan housing, flowing along the wall without stopping the fan blades as it would on Earth. The teams realized this fairly soon after the incident and then focused on determining how the water had entered the ventilation system in the first place.

Because the investigation was expected to take quite some time, the team worried about calling a halt to EVAs for several months. The team needed to have the ability to perform EVAs while the investigation was ongoing. Without knowing the failure's exact cause (root cause), the team developed procedures to have the crew to take safing actions and return to the airlock if this happened again. A helmet absorption pad, which was attached by Velcro to the inside of the helmet, and a snorkel that extends from the crew member's mouth down to the waist area were designed and quickly flown to the ISS.

The EMU has a fan for oxygen ventilation, a pump for water circulation, and a water separator for condensation gathering that are coupled together through a common shaft and magnetism. The unit is called the Fan/Pump/Separator (Figure 11). The water separator portion of the FPS in Parmitano's suit had become clogged with tiny particles, causing water to back up and deposit into the fan.

## Planning and Training Extravehicular Activity Tasks

When the external portions of the ISS were being designed, the engineers and managers often made compromises between how much time would be spent assembling or repairing a component via EVA versus the use of robotic or automated systems. Many factors had to be considered, including the

complexity of performing a task in space by a human or a robotic arm, the mass or size of the item, the cost of manufacturing the hardware or software for each option, and of course the schedule. To reduce the amount of EVA time to assemble the ISS, engineers designed modules and some truss segments with automated bolts and power and data connectors to create a permanent interface. When possible, automated mechanisms deployed appendages

such as antennas and solar arrays that had to be tucked down to a lower profile to fit in the cargo bay of the Space Shuttle. However, having a human perform a spacewalk allowed for lower-complexity designs with simpler bolts or mechanisms driven by powered drills that were held by EVA crew members. Also, an EVA crew could assist with human intervention to save the day when automated systems encountered a failure.



EMU with backpack facing Steve, who unzipped the white thermal cover and tilted the suit down to access the suit components.

Fan/Pump/Separator unit, removed from suit

Tether Stowage Area

**Figure 11.** Astronaut Steve Swanson holds a Fan/Pump/Separator unit (with protective cylinder installed on the end). Several of these units were changed out in the on-board suits due to failures, as well as to investigate the cause of an incident on US EVA 23 where water entered a crew member's helmet. The EMU is installed in a rack that assists with suit donning, and it is tilted down with the backpack cover unzipped to expose the suit's life support system. Below the EMU is the tether stowage area in the Equipment Lock.

The investigation found that some filter devices used to clean the water system of the suit during periodic maintenance (to control microbial growth and take out other contaminants) were inadvertently exposed to impure ground water. These were launched to the ISS and used with Parmitano's suit and the other suits, and were likely the source for the majority of the particles that caused the clog. Numerous potential contributing factors were associated with Parmitano's

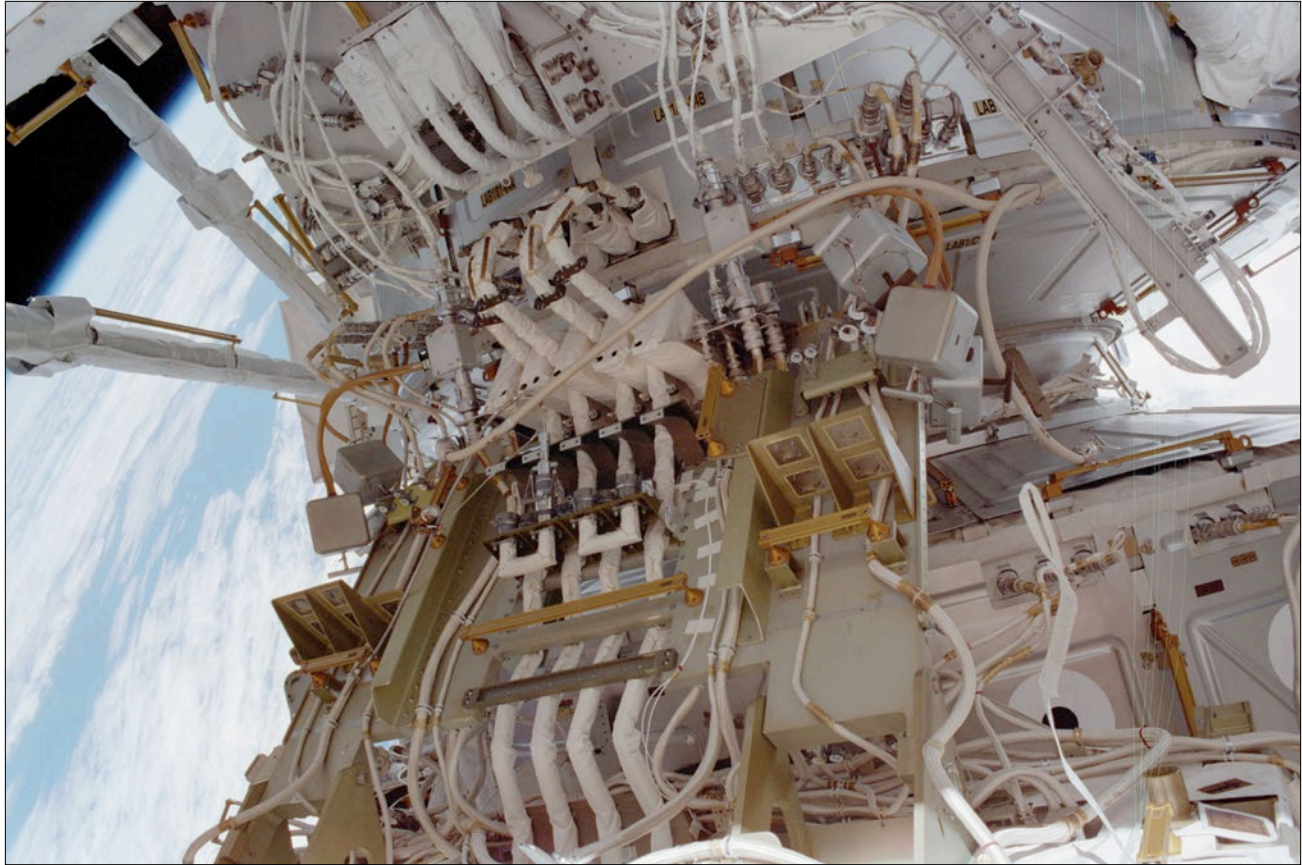
suit (e.g., excessive grease could have been in the system, applied to the seals).

The airlock system was flushed with water, several EMU components were changed out, and the filters in question are now carefully manufactured with pure water flowing through them. The helmet absorption pad and snorkel are used for all US EVAs. Crews and ground teams are now very well trained for this failure mode.

After weighing the various factors for each interface, the ISS and especially the US Segment ended up requiring a lot of EVA time to assemble. Use of the large Canadian robotic arm is often still required to reach otherwise-inaccessible areas of the ISS and to secure an astronaut's feet so he or she can grip something with both hands (e.g., while moving an item to another area on the ISS).

On paper, the tasks needed for ISS assembly—e.g., driving a bolt, carrying something from one place to another, taking off a cover, plugging in an electrical cord—might not seem too complex. However, conducting such tasks while wearing a spacesuit with pressurized gloves (possibly with one's feet planted on the end of a long robotic arm), working in microgravity, maneuvering around huge structures while moving massive objects, having time constraints based

on spacesuit consumables, and using specialized equipment and tools made these tasks and EVAs challenging. Tasks such as working with cables or fluid hoses (Figure 12) are hand-intensive work—fingers and forearms get quite a workout in pressurized gloves that feel like stiff balloons and resemble oversized garden gloves. Added to these complexities, space “walking” is mostly done with the hands. The astronaut grasps handholds and maneuvers the



**Figure 12.** Modules had to be connected, by hand, with stiff hoses for ammonia transfer as well as electrical power connections. Hand and EMU access was often tight. The crew had to carefully avoid snagging the lines with tools and tethers. The actual “flight hardware” connections were piecemeal tested to the extent possible, but the full three-dimensional (3-D) geometry with the crew in real EMUs was impossible to fully simulate on the ground. The Laboratory (top) and Node 1 (bottom) are the silver modules under all of the cabling in this photo from STS-110/ISS-8A.

combination of the EMU, SAFER, tools, and himself of herself around the structure.

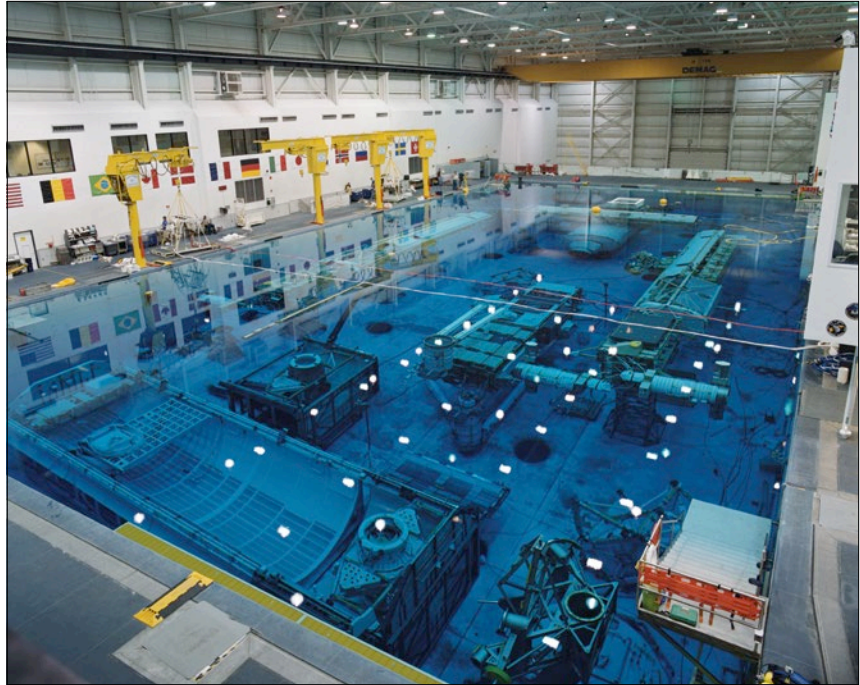
The team on the ground has to come up with a choreography and order of events for the EVA, in advance. The flight control team creates the EVA timelines based on a high-level prioritized list of tasks determined by ISS management (e.g., move a specific antenna, install a particular avionics box). The flight controllers start with the top ISS priority task and assesses the other tasks that can

fit into the EVA based on multiple factors such as how long the tasks will take based on past experiences, whether both crew members need to work together, task location on the ISS, how much equipment will fit into the airlock, the tools required, crew experience level, and the level of crew effort to complete the task. A task that might fit (but only if the team is efficient) is put on the list as a “get-ahead” task. See also Chapter 4. Real-time discussions in Mission Control of EVA time remaining, crew fatigue, and suit consumables

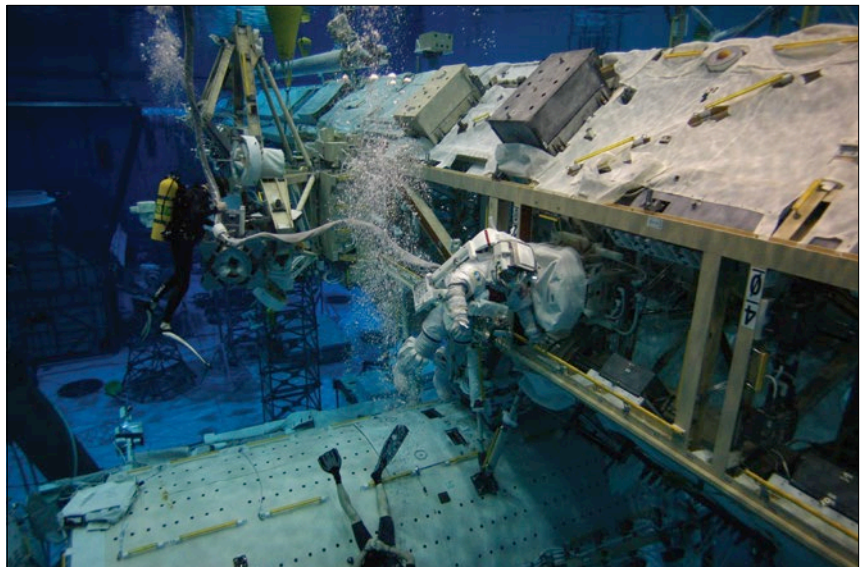
could allow the get-ahead task to be accomplished in addition to the planned tasks. Some tasks are performed on a “clock”; i.e., if power is removed from an item, it might get cold and need heater power in a matter of hours or sometimes within minutes to prevent damage. While a timeline is still in a draft version, the team conducts testing as required to prove out the operations. The team then trains the crew and refines and/or changes the timeline, sometimes up to the day of the EVA.

## Extravehicular Activity Testing and Training

Testing and crew training for an EVA takes place in many facilities due to the complexities associated with adequately mimicking microgravity, working in a spacesuit, and the large scale of the ISS. One of the main facilities used for EVA development and crew training is the Neutral Buoyancy Laboratory (NBL)—a large pool that measures approximately 61 m (200 ft) long by 30 m (100 ft) wide by 12 m (40 ft) deep—near Johnson Space Center in Houston, Texas (Figure 13). Training versions of EMUs are balanced by scuba divers with weights so the test subject does not sink or float and can work as he or she would in zero gravity. The underwater suits each use an umbilical hose that goes to the surface to supply breathing gas and cooling. The divers manage this umbilical, thus the crew usually does not know it is there. Water does not provide a perfect model for space—the ISS mock-up and tools corrode over time, the water drag makes large objects (including the crew members) harder to start moving and easier to stop moving than in space, and equipment is inclined to float or fall in a manner that it would not in space. Also, the ISS is so big that the entire structure does not fit in the pool, so it is broken into pieces. When the crew members translate along the ISS structure in the pool, the divers must assist by physically moving the crew members between parts of the ISS when there is a gap between structures (Figure 14). The NBL replaced the Weightless Environment Training Facility at



**Figure 13.** The NBL near Johnson Space Center. Above the water level is the control room, a mini Mission Control, visible on the far right behind the white wall. The yellow cranes are used to hoist crew or other test subjects into the water. The crew must use special EMUs that are made to be used in the water. The mock-ups underwater include the Laboratory Destiny with the central piece of the truss structure on top (farthest away), truss and solar array structures (center and right), and the Space Shuttle's cargo bay (foreground).

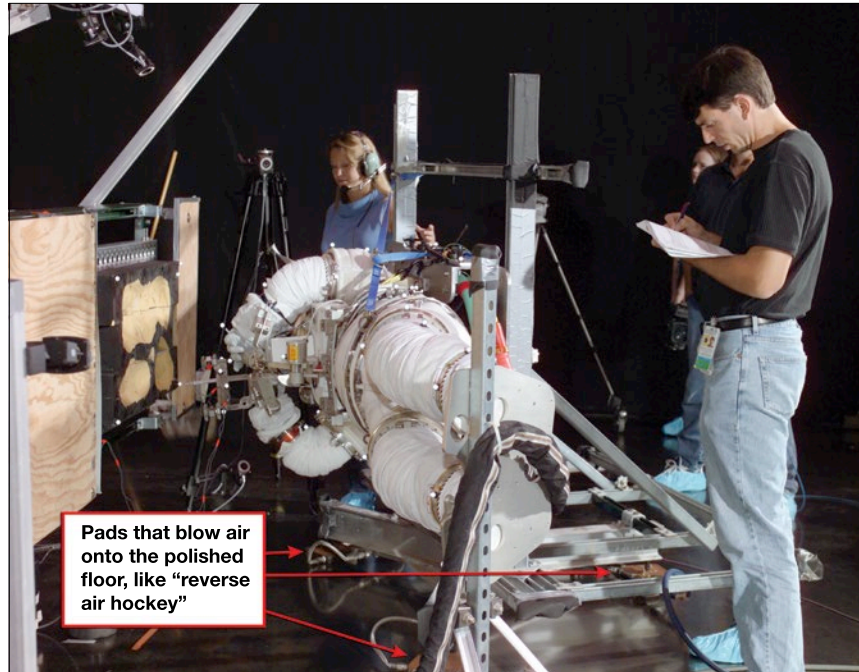


**Figure 14.** An astronaut (i.e., the test subject) translates along the forward face of the mocked-up ISS truss, with a scuba diver assisting to keep the air and cooling umbilical from becoming entangled or pulling on the EMU.

Johnson Space Center and is where most of the EVA choreography is currently tested. However, the Weightless Environment Test System in Tsukuba, Japan, and the Neutral Buoyancy Simulator in Huntsville, Alabama, have also made major test contributions to ISS EVAs.

Space Shuttle crews for ISS assembly missions were trained multiple times in the NBL on their EVA choreography using the specific tools and required tethers. ISS crews remain on station for a much longer amount of time, and they have long preflight training periods in multiple countries and can't be expected to remember fine details for extended periods. EVA priorities often change after months of ISS operation anyway. Therefore, the ISS crews are trained on some specific EVA tasks, but their training focuses mainly on skill building (e.g., giving robotic arm operator directions, rescuing the other EVA crew member) rather than on memorizing choreography.

EVA teams use a variety of other locations for testing and training. Vacuum chambers are used to verify that spacesuits do not leak in the vacuum of space. They are also used to test when reduced pressures (sometimes coupled with extreme temperatures) might affect operations, such as with the friction between moving parts, bubbling of substances, or stiffness of hoses. Moving massive objects by hand is not feasible when simply standing on the ground, so teams put high-mass objects on a system that blows air onto a polished steel floor and allows movement via principles similar to an air hockey table (Figure 15). This gives astronauts and test subjects a more-



**Figure 15.** The Precision Air Bearing Facility, with a test subject inside an EMU. Air blows out of pads on which the EMU is resting, so the unit will slide based on how the person inside the EMU moves or when pushed. In this case—a test that followed the Columbia accident—the subject was pushed to slide along the floor as if flying a SAFER while using a tool to measure damage to Space Shuttle tiles.

realistic feel for starting and stopping movement of heavy equipment since neutrally buoyant objects in a pool still tend to twist and float when affected by trapped air.

Another key training facility is the Virtual Reality laboratory, which allows the test subject to view a graphic ISS in 3-D (often while wearing a helmet with goggles). This makes it possible for the teams to envision the workspace and practice EVA-robotics choreography (Figure 16).

One famous testing platform was the “Vomit Comet” aircraft that allowed for intermittent periods of weightlessness. The KC-135 aircraft (later replaced by a DC-9) was outfitted to fly a parabolic

trajectory and provide approximately 20 to 25 seconds of microgravity at a time. This allowed for quick tests with flight-like materials that could not be done underwater or that needed microgravity.

Often, the team proves out techniques and uses EVA tools on real flight hardware while it is still in an assembly facility on the ground. It is better for NASA to discover that something is too difficult to reach/manipulate/turn by EVA crew members, or that tools don't fit their interface, while on the ground rather than in space. Hardware obviously cannot be ground-tested in this way after it is already on orbit, which adds to the challenge now that ISS assembly is complete.





**Figure 16.** Astronaut Dan Burbank flies a mocked-up SAFER unit in the Virtual Reality laboratory. He is seeing the space station in 3-D and using the hand controller to “fly” back to the ISS. This provides a simulation of what it would be like if his tether broke and he detached from the structure.

All told, the preflight EVA development process is fairly lengthy and complex. In an attempt to make designs EVA-friendly, with handholds and interfaces for standard EVA tools, NASA levied requirements on the ISS hardware designs. The operations team often works with the design team during development. Analysis and preliminary design would often lead to building mock-ups for preliminary testing underwater. EVA teams might test choreography for an EVA several times in the NBL. The teams also go to different facilities around the country to test the fit of tools, put together pieces of the real ISS, and try out putting blankets on structure—all things that cannot be done realistically

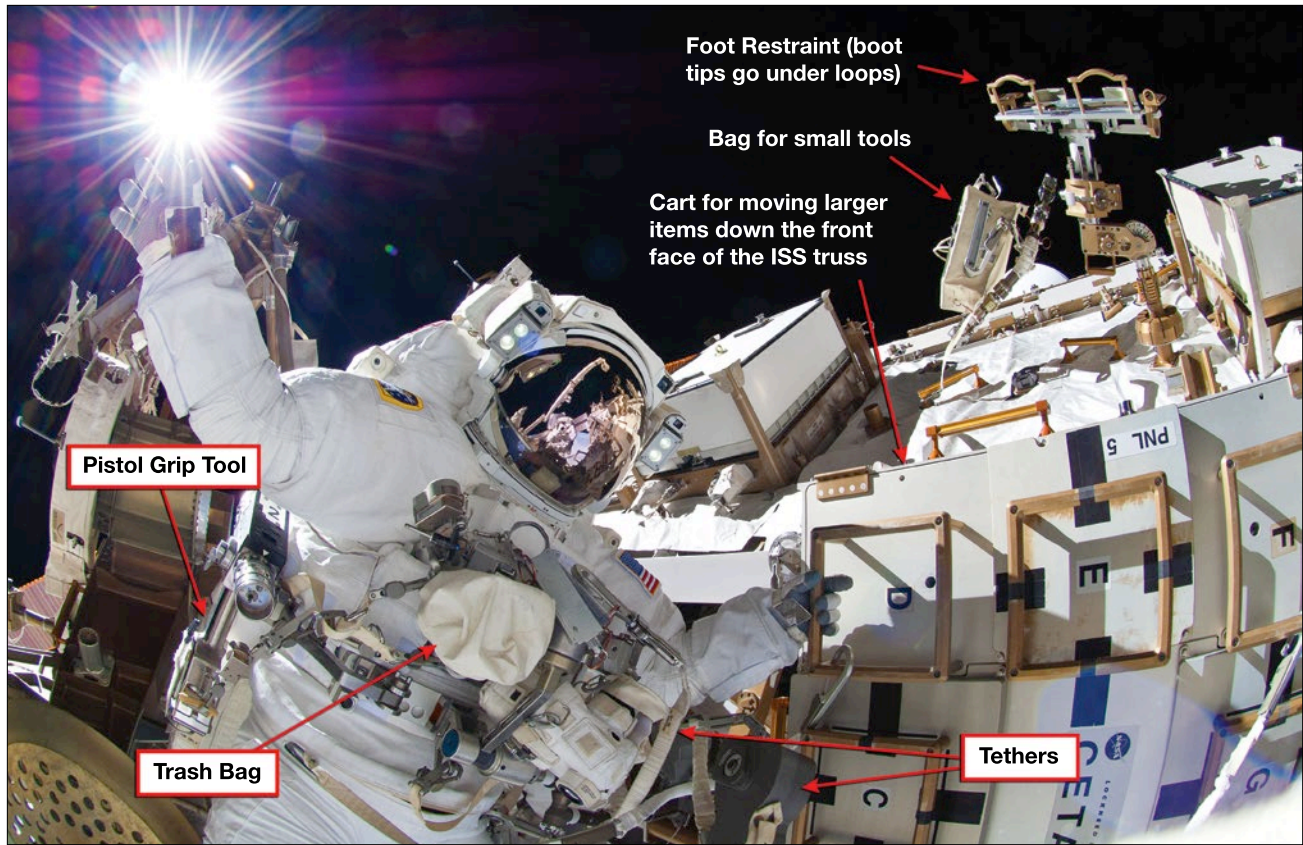
underwater. Astronauts typically get into a spacesuit and go through the procedures for depressurizing the airlock to get a feel for the stiffness and sounds of a flight-like spacesuit. The crew slated for a spacewalk will practice flying SAFER in the Virtual Reality laboratory, as well as practice calling for robotic movement from the crew inside (e.g., “Move me down to the structure”). For assembly, crews would get into the real Space Shuttle cargo bay where ISS elements were located, as well as look at Space Shuttle interfaces in case of Space Shuttle off-nominal situations that might need an EVA. Astronauts may participate in other specialty classes and tests associated with tools or ISS hardware to further prepare them for a plethora of

situations. After all is said and done, the EVA development effort involves many operations experts, hardware and EVA tool designers, analysts, experienced astronauts, safety experts, and facility experts.

## Extravehicular Activity Tools

Tethers (cords) are critical for keeping hardware from floating away and act as lifelines back to the ISS structure (Figure 17). Some tethers are retractable and can be temporarily locked out (similar to a measuring tape), while others are a fixed length. Tethers are a constant source of discussion and can be key to the choreography, so the team carefully considers where a tether is best anchored on the crew member or structure. Work sites are often farther from the airlock than the length of a single tether, thereby requiring multiple tethers to be strung together or used in combination, which increases the complexity of getting somewhere and ensuring the astronauts always “make” (i.e., close the hook for) a connection before they “break” (i.e., open the hook from) the previous connection. Occasionally, a crew member can end up in a “snarl” or get snagged by a cord. In these cases, the astronaut must carefully untangle himself/herself or the equipment, although the EVA choreography is designed to prevent such tangling.

Crew members often use foot restraints when they need to work on something with two hands. In microgravity, actions such as pushing a piece of equipment or a tool would cause the astronaut to float in the



**Figure 17.** This photo of astronaut Sunita “Suni” Williams was taken by astronaut Aki Hoshide during Expedition 32. A fairly standard quantity of tools can be seen on the front of her spacesuit, although each EVA requires a somewhat different complement of tools. Two versions of safety tethers are attached to D-shaped rings on the suit near the hips, and one of these has a take-up reel that houses a 26-m (85-ft) steel cable. This safety tether can be attached to the structure and allows the crew member to travel far without having to relocate his or her tether point. However, if the crew member were to let go with only this cable attached, he or she could float away from structure and possibly come back to impact an unintended area off of the ISS. Other tethers are often used in addition to safety tethers, once a crew member arrives at the work area. A Pistol Grip Tool (under Williams’ arm) has functions similar to a cordless drill used for bolting and unbolting equipment. She is holding onto a cart that can translate along the truss but is rarely used for this purpose.

opposite direction, something that doesn’t happen on the Earth where a person’s feet anchor the body against these forces. Another stabilization tool is the Body Restraint Tether—a device attached to the EMU that clamps to a handhold on the ISS and can be made rigid to hold a crew member steady. This tether is actually a stack of balls with a cord through the middle and a tightening mechanism, similar to a shop light or camera mount. A computerized

Pistol Grip Tool is comparable to a sophisticated power screwdriver or cordless drill used to install or remove bolts when precise torque or turns are required.

In addition to specialized tools for some tasks, common tools that were made EVA-friendly include wrenches and sockets, bags to keep tools contained, cameras, trash bags, etc. A tool mount called a Mini-Workstation on the front of the suit contains often-needed tools, ready and within reach.

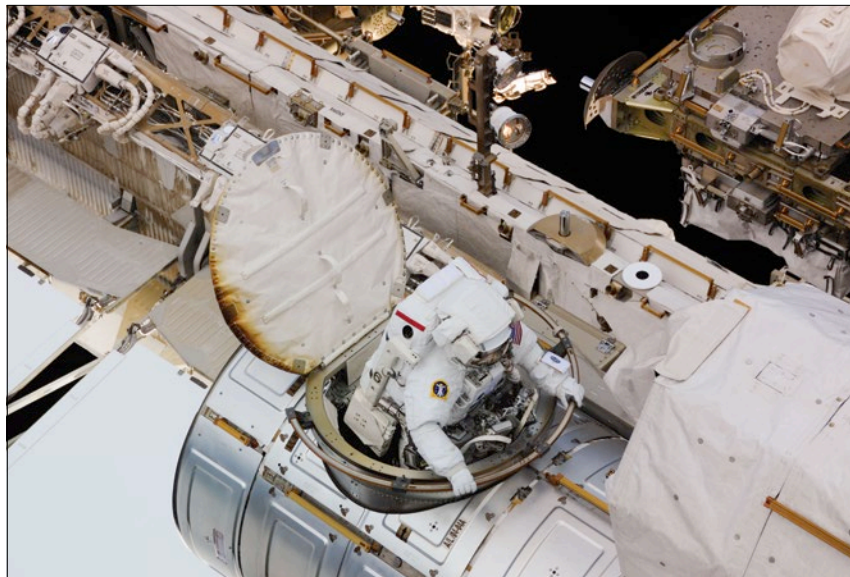
## Extravehicular Activity Preparations and the Airlock

For an EVA to be conducted, the crew has to get outside without taking the entire ISS cabin pressure down to vacuum. Thus, the suited-up EVA crew members go into a telephone booth-sized airlock that is depressed to vacuum just prior to the EVA. That small volume on the ISS that goes to vacuum is called the Crewlock, which is part

of a larger module called the Joint Airlock (Quest). The Joint Airlock houses the Crewlock and also has an Equipment Lock that holds EVA suits and equipment for storage and allows for suit donning and doffing. A Russian-designed depress pump is used to reclaim most of the Crewlock air for continued use in the cabin, rather than depressing the volume of the Crewlock by opening a valve to space in order to equalize with the vacuum of space (Figure 18).

Airlock systems also provide vital consumables via umbilicals, or hoses, prior to the crew exiting the airlock. This allows the astronauts to complete their work before starting the spacewalk without using the limited quantities in the spacesuit. These consumables include oxygen and water, as well as power to avoid battery usage, “hardline” (i.e., not using radio) communication, and crew member cooling via an umbilical that attaches to the EMU on one end and an airlock panel on the other. When the team is ready to start the EVA, the astronauts disconnect the umbilical. If need be, the crew members can return to the airlock during an EVA to briefly connect the umbilical and refill oxygen, but this might not fit into a tight timeline if the worksites are far from the airlock.

The morning of an EVA, the crew members get into the EMU by putting on the Maximum Absorption Garment, then a two-piece thin body undergarment resembling long johns for comfort under the LCVG, which will be put on next, followed by the pants (i.e., the Lower Torso Assembly) (Figure 19). The crew member gets into the upper portion



**Figure 18.** Astronaut Doug Wheelock exits through the EVA hatch of the Joint Airlock. A thermal cover (shown directly behind him) keeps the airlock and its hatch at a stable temperature. This flap is closed by a Velcro fixture and must be opened when a crew member goes into or comes out of the hatch. The hatch itself cannot be seen in this photo because the hatch opens into the airlock.



**Figure 19.** The EMU is donned by putting on the pants (Lower Torso Assembly) and then coming up from the bottom of the shirt (Hard Upper Torso). The crew member puts his or her arms through the sleeves and puts his or her head in the neck of the suit. The astronaut is usually assisted by an unsuited crew member when putting on the communications cap, mating the pants and shirt, and installing helmet and gloves.

of the suit by putting his or her arms through the suit arms mounted on a Hard Upper Torso, as if putting on a shirt over the head. The pants mate up to that Hard Upper Torso and seal in a ring around the crew member's waist. Then, the communications cap, helmet, and gloves are donned as the suit gets powered up (Figure 20). After suit up, a leak check is performed to ensure the suit does not have any unexpected gas leakage—something as small as a human hair in between two seals will cause a noticeable leak and result in the crew having to double-check the connections. A leak check is accomplished by monitoring the pressure in the suit for 1 minute and verifying the pressure doesn't change unexpectedly.

One of the last things installed on the EMUs before an EVA is the SAFER, which the crew can use to fly back to the structure if tethering fails (Figures 2, 21, and 22).

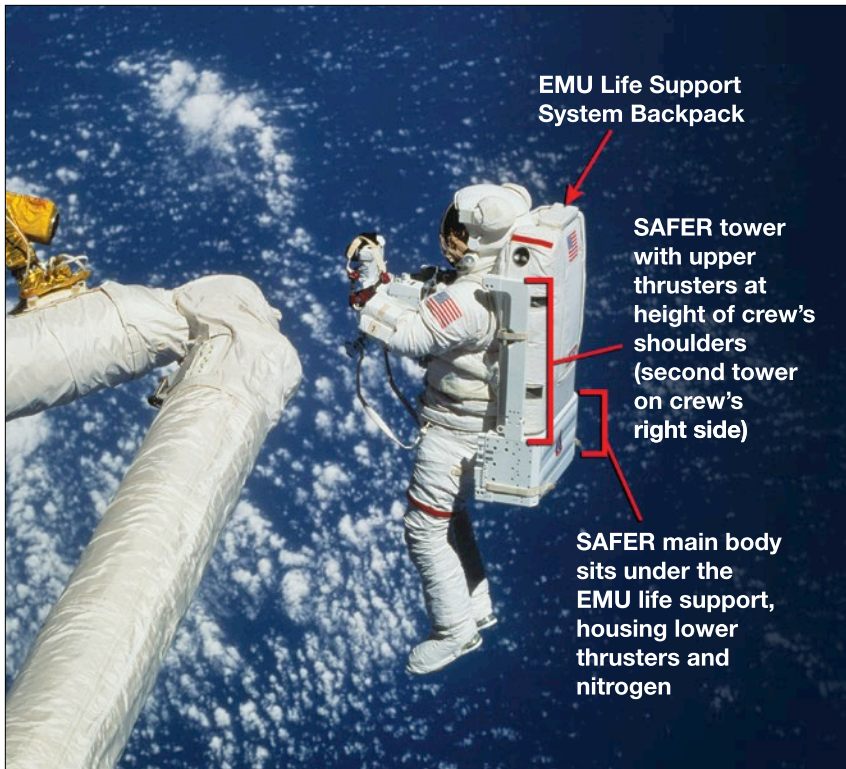
Prior to each EVA, an oxygen prebreathe is conducted to prevent the crew from getting the bends after depressurization of the airlock (i.e., when the absolute suit pressure drops to 222 mm Hg [4.3 psi]). This is the same DCS that ascending scuba divers as well as aviators at high altitudes must also prevent. Breathing 100% oxygen forces nitrogen to migrate out of tissues and is exhaled. If done for long enough, the chances are greatly reduced that these gases will create harmful bubbles that can lodge in joints or travel in the



**Figure 20.** Astronauts Steve Smith and Rex Walheim are suited up in the Equipment Lock during STS-110/ISS-8A. Walheim, on the right, already has a Mini-Workstation of tools installed on his chest. Jerry Ross, seen in the Crewlock in the background, helped as an intravehicular crew member for this EVA.



**Figure 21.** The SAFER on the right is attached to the EMU before the crew gets into the Crewlock for airlock depress. A hand controller, similar to a joystick, stays tucked into a storage area. If a crew member needs to rescue himself or herself by flying back to the ISS structure, the hand controller can be removed from storage quickly.



**Figure 22.** SAFER installed during a test on Space Shuttle flight STS-64.

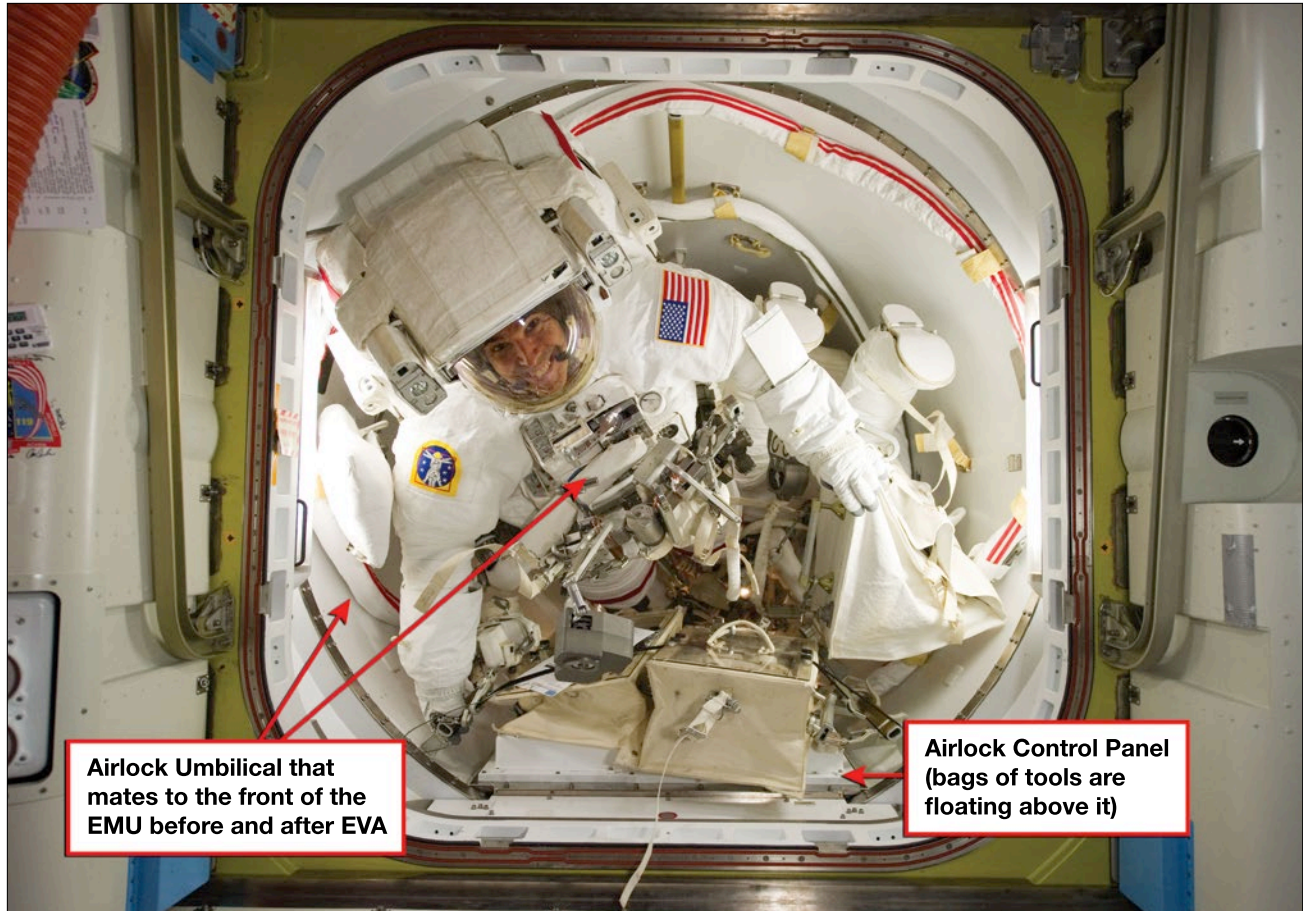


**Figure 23.** Astronaut Chris Cassidy is shown prior to an EVA during one portion of his prebreathe of pure oxygen to prevent DCS. In addition to an oxygen mask, he is wearing his LCVG, with small water-filled tubes throughout and larger ventilation ducts, as seen on his left arm and on his right waist. The Crewlock that goes to vacuum (located behind Cassidy) is filled with tools and storage bags. The suit umbilicals are attached to an umbilical interface panel in the Crewlock on one end and the EMUs on the other end. The EMUs are in the Equipment Lock in the foreground. One suit umbilical is routed under Cassidy's arm and is connected to a suit, seen in the lower right corner of the photo.

bloodstream to critical organs, resulting in pain, severe medical issues, and even death.

Multiple prebreathe protocols have been available and used on the Space Shuttle and the ISS. The various protocols can involve oxygen masks, exercise in the suit or on a bicycle machine, reduction in cabin pressure to 528 mm Hg (10.2 psi) (~equivalent to 3 km [10,000 ft] altitude) for a period of time, and/or prebreathe in the spacesuit. Prebreathe methods have evolved to incorporate reductions in crew day length and reduced complexity. For example, at one point, prebreathe (Figure 23) involved having the EVA crew sleep in the Joint Airlock overnight at a reduced cabin pressure; however, this had its pitfalls. In addition to sequestering the extravehicular crew members from their crewmates and the toilet, certain failures such as a fire alarm on the ISS will cause a repress of the airlock and will interrupt the prebreathe process. This can be frustrating when the alarm is false, as has happened in the past, since any interruptions in prebreathe protocol require strict penalties to “buy back” the time. Depending on the situation, the crew might have to breathe pure oxygen for twice the number of minutes than was the interruption.

If a crew member exhibits DCS symptoms during an EVA, he or she will be brought inside as quickly as possible (with assistance from the other crew member, as required). The airlock will be repressurized, which immediately aids in recovery. The suit



**Airlock Umbilical that mates to the front of the EMU before and after EVA**

**Airlock Control Panel (bags of tools are floating above it)**

**Figure 24.** The Crewlock is crowded with two crew members, tools, bags, and spare parts. Shirtsleeve crew members essentially stuff the crew in, with one crew member facing the hatch to be able to open it for egress to space and the other crew member facing a panel to operate the airlock. This is a photo of astronaut Rick Mastracchio (astronaut Clay Anderson's feet are also shown) during STS-131/ISS-19A while the Space Shuttle was docked to the ISS.

can also be pumped up to 413 mm Hg (8 psi) beyond the standard cabin pressure to help collapse bubbles in the crew member's body. The flight surgeons in the control center will make medical recommendations while the EVA flight controllers work with the other crew members on the steps for installing and operating a device to allow the pressure of the suit to get this high.

Quite a bit of overhead is involved in performing spacewalks

(Figures 24 and 25), with more than 100 on-board crew hours logged before and after EVAs. Time is spent configuring the suits, preparing the tools with the exact complement needed (the astronaut cannot go back inside the ISS to grab a missing tool), studying the spacewalk (which may take place months after the last training run or is a contingency timeline that the crew never actually simulated), conducting refresher training on failures that could occur, discussing

the robotics interaction with the EVA crew, and discussing the details with the ground team. The EVA flight control team will also collectively spend hundreds of hours planning and executing these activities.

The Wall of EVA needed for ISS assembly required countless hours of preparations both on the ground and in space—and that was after all of the preflight ground testing and training. With the ISS in steady-state operations, science objectives



**Figure 25.** Astronaut Dan Tani is shown sleeping among the equipment between EVAs on STS-120/ ISS-10A. Notice the sign pointing into the airlock on the left. Some EMU equipment and unused EMUs are moved out from the larger part of the airlock where the crew suits up.

compete with these EVA-related hours. Two or three EVAs are often grouped over the course of a couple of weeks, which reduces some of the overall number of hours spent. For example, if a suit will be reused by the same crew member on one increment, it doesn't have to be resized. In addition, the crew members are more current on their training (e.g., SAFER flying, suit emergencies, no-touch areas of ISS due to sharp edges), making the process more efficient.

### Executing Extravehicular Activities: Managing the Risks

EVAs are exciting and intense for the on-board crew and for the flight control team. The crew and the ISS are in a more-risky situation during a spacewalk, and the suit consumables are limited so time is of the essence. Crew members are exposed to the potential of DCS, a feeling of vertigo looking at the Earth, and extreme fatigue that could hinder their ability

to get back to the airlock. The crew is less protected from MMOD than when inside the ISS, so there is a greater risk of MMOD penetrating the suit and injuring the crew member. Although crew training and good equipment should prevent a disconnect, a crew member may become untethered and have to use SAFER to fly back to the structure. Robotic arm maneuvers, while offering spectacular views, require EVA crew members to wedge their heels against the foot restraint to

keep from disengaging and floating away from the robotic arm. The crew members would remain attached to the ISS via their long retractable tethers, but this would be quite a debacle if a crew member was carrying a large piece of hardware.

Risks to the ISS occur during EVAs due to the very nature of the human element and the potential for additional failures. A suit problem could force an EVA to be terminated (ended expeditiously) or aborted (ended extremely quickly in an emergency fashion to save a crew member's life). For example, the control team terminated an EVA during STS-118/ISS-13A.1 (2007) due to unexpected glove damage, and during US EVA 23 (2013) when water entered a crew member's helmet (see sidebar: US Extravehicular Activity 23 Water-in-Helmet Incident). In some cases, ending an EVA early could mean that bags or tethers block rotation of critical appendages such as the solar arrays or could block robotic movement. Also, if a large piece of the ISS is not tied down adequately with tethers, then it is possible that vehicles such as Soyuz could not dock or undock safely without the risk of having equipment fall off and impact other structures or vehicles.

The EVA console in Mission Control Center (MCC) provides a status to the flight director and flight control team on the amount of consumables left in each EMU. The consumables include the oxygen quantity in the primary tanks, the capacity of the CCC in terms of ability to continue to remove carbon dioxide, water available for sublimator use, and

battery power. The quantity of available oxygen is directly measured and sent to MCC in telemetry. The CCC does not put out telemetry of its capacity. This is derived based on how much oxygen a crew member is using, which is an indicator of his or her metabolic rate. From this metabolic rate over the course of the EVA, the team can determine the remaining CCC capacity based on the predicted capacity and subtracting out the already-used quantity. Water usage is not known until the reserve water comes on (automatically turned on due to reduced line pressure when the primary water is used up). In that case, the crew and ground will receive an alert that 30 minutes remain, assuming a hole is not causing leakage, which would reduce the available time. Battery power is predicted and voltage can be measured for unexpected reduction in the remaining time available.

The flight control team works to ensure the critical tasks get done while keeping an eye on consumables and crew health. Sometimes, predicting what the consumables will be is a challenge in this regard. For example, the limiting consumable (the one with the least amount of time remaining) is often the CCC. However, a crew member's metabolic rate varies over the course of an EVA, with lower metabolic rates when on the Space Station Robotics Manipulator System. But high-effort tasks increase metabolic rate. Thus, determining whether a task is achievable in that EVA requires some predictive skills before an astronaut starts the task. Training runs in the NBL help establish trends for specific crew members. Oxygen

can be recharged (refilled) by having the crew go into the airlock and connect to the umbilical, although this could significantly alter the choreography of the EVA.

EVAs involve the human element both in space and on the ground. Crew member height and arm length can make a big difference in whether that crew member can perform a particular task. Mechanical aptitude is critical as well. The ISS needs someone who knows how to turn a wrench as much as they know science. Some complex tasks require very good back-and-forth communication between the crew and the ground, so language and patience are also factors. Assembly mission EVAs used the on-board crew (called "IV" for intravehicular) to read the instructions to EVA crew members and keep them on task; for standard increment operations EVAs, a "Ground IV" relays the details of each step from MCC.

EVAs are physically demanding; therefore, crew fatigue is a major consideration during a spacewalk. Sometimes an EVA will go longer than planned because a task at the end of an EVA takes longer than anticipated due to crew member fatigue. Ground discussion among themselves and what information is exchanged with the crew on board is often key in decision making and the success of an EVA.

Exposure to toxic chemicals during a spacewalk is another hazard that is carefully managed. The external coolant on the ISS is ammonia that, even in very small amounts, could be lethal if it gets stuck on the EMU or tools and the crew member brings



it back into the cabin. Several times, the spacewalking crew has been exposed to ammonia. The potential to bring ammonia back inside can be reduced by requiring the crew “bake out” before coming through the airlock (i.e., spend additional time outside to allow sublimation of the ammonia into vapor form, off the suit). If there is doubt that crew members might still have ammonia crystals on their suits, NASA may elect to have the crew use a piece of sampling equipment called a Draeger tube to test for the presence of ammonia. Partially repressed airlock air would mix with ammonia on the crew member’s suits and tools, and visibly turn reactant chemicals in the glass vial tube from yellow to blue.

Equipment that is “dropped” overboard due to missing a tether connection or other problem is tracked by ground radar, if the item is big enough to be picked up on radar. However, there is potential for these objects to re-contact the ISS, contact another vehicle approaching or leaving the ISS, or in some cases survive reentry into Earth’s atmosphere and potentially harm people on the ground. Also, the now-missing equipment may be critical to the repair or task at hand, and the team will have to determine whether it can be accomplished on that EVA. Lost equipment in the past has included tools, a bag full of tools, and a camera. Occasionally, the ISS Program will approve an object to be dropped overboard intentionally as a jettison if it can be thrown in a particular direction and proven to result in extremely minimal risk to the ISS and people on the ground.

The largest object ever jettisoned from the ISS was the Early Ammonia Servicer, a 544 kg (1,200 lb) tank of ammonia in 2007.

The US Segment assembly of the ISS often involved robotic installation or partial installation of a major element when a Space Shuttle first arrived, followed by a series of three to four EVAs to structurally secure the element, hook up power and data connections, and perform related tasks. These EVAs were sometimes nail-biters, because a small issue had the ability to trip up the team and amount to an element freezing or the inability to fully safe the systems (Chapter 4). The mission time was limited and the Space Shuttle crew was specifically trained for some of the tasks, so changes to the EVAs during the docked Space Shuttle timeframe were often added into that short period with incredibly fast EVA development time. Over the years, many small issues (e.g., stuck bolt that would not release) as well as major issues (e.g., the entire tray of electrical and fluid lines that would not initially deploy while the equipment was waiting for power) were overcome by the crew and ground team to complete the mission at hand.

Post-assembly, the intensity remains for many tasks, especially those that involve repair of a critical ISS systems unit. One example of critical EVAs to repair the ISS is the set of two EVAs that followed the external pump failure that occurred in 2013, which required the EVA team and crew to prepare and execute EVAs within a period of a couple of weeks. Further details of this situation are provided in Chapter 20.

## **International Space Station Extravehicular Activities—A Benefit to Humanity**

This chapter was written as a general overview, but the real ISS hardware build-up for Space Station assembly transpired with extremely great detail at all steps along the way. Every part of the EMU is carefully maintained and rotated. Every aspect of every EVA is carefully planned (to the extent possible on Earth) and executed. The team of people involved is extensive, from the ISS hardware engineers to the suit engineers to the divers in the NBL—and the dedication to safety and great detail from everyone is awe-inspiring.

Two chapters in this book (Chapters 18 and 20) highlight the critical role an EVA can have in keeping the ISS functioning. A peripheral benefit to the experience is also gained by building the ISS by hand. The intensity, quantity, and complexity of ISS EVAs could be considered a drop in the bucket compared to a program such as an exploration mission to Mars. The ISS provides many benefits to society. Through the ISS, NASA is learning ways to improve EVA efficiency, reduce overhead in preparations, and improve spacecraft design so that fewer failures occur. The training and experience gained in doing these low-Earth orbit EVAs will be invaluable for exploration of other worlds.



## Chapter 18 Day in the Life:

Risky and Rewarding  
Spacewalks—  
Space Shuttle Mission  
STS-120/ISS-10A



*Doug Wheelock and Scott Parazynski (in the spacesuits—left and right, respectively) are assisted in the airlock during Space Shuttle mission STS-120/ISS-10A by European Space Agency astronaut Paolo Nespoli and International Space Station Commander Peggy Whitson.*

***The International Space Station (ISS) Program always presents new and sometimes daunting challenges.*** Each morning, the individuals working in Flight Operations never know whether the day might present one of the most critical problems in the history of the space station—whether the team will have to do something that has never been attempted.

Scripting and training a spacewalk (i.e., extravehicular activity [EVA]) in advance is a major effort; however, the real-time execution of spacewalks usually requires deviating from the original plan. Problems with the

ISS systems that require an EVA fix can arise, tasks may take longer than expected, or a spacesuit issue might end an EVA early. Quick-decision moments are fairly common. Spacewalks are physically rigorous. The “human-in-the-loop”—both in space and on the ground—often necessitates flexibility. None of the space station parts were ever able to be tested preflight by a suited crew member in space-like thermal, zero-g, and vacuum conditions. When these factors come together in space, problems such as stuck bolts or problematic hinges can occur. The critical decisions made in the midst of never-before-seen technical or human

problems during EVAs intensely draw upon the Foundations of Mission Control (see Introduction).

Take one Space Shuttle mission to the ISS, as an example. Space Transportation System (STS)-120/ISS-10A launched late in October 2007. Despite extensive EVA choreography preparations for the mission objectives, the planned spacewalks changed dramatically once the mission was under way. This chapter discusses the work that was done preflight and how it changed—not once, but multiple times—as the flight control team adapted to an ever-changing situation.

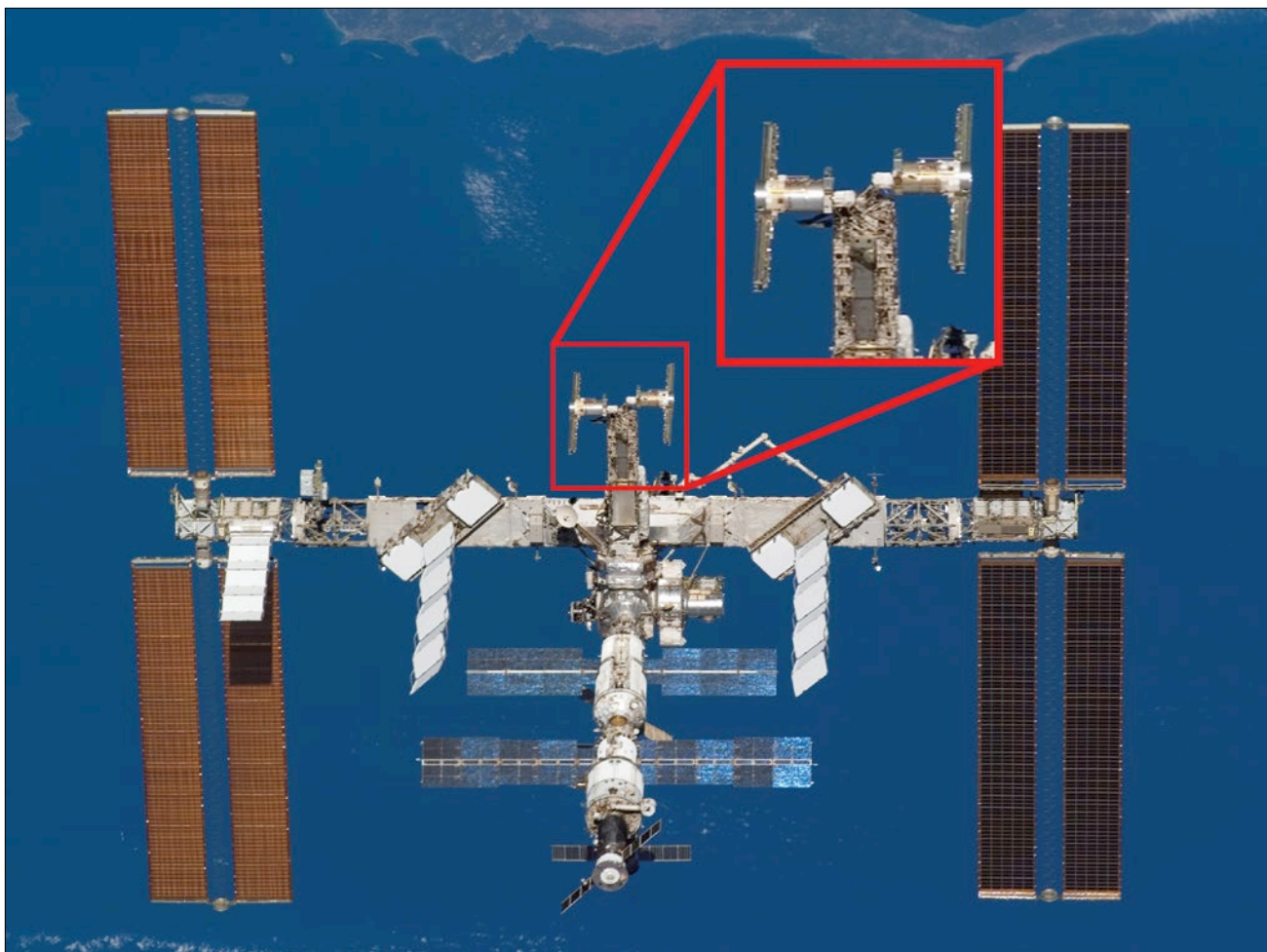
## The Original Mission

One of the top objectives for STS-120 was to deliver the pressurized module called Node 2 by robotically removing it from the Space Shuttle cargo bay and installing it on a temporary location on Node 1. The Node 2 module was a critical element in that the European Space Agency (ESA) and Japan Aerospace Exploration Agency modules would attach to it, making way for new countries to have permanent presence

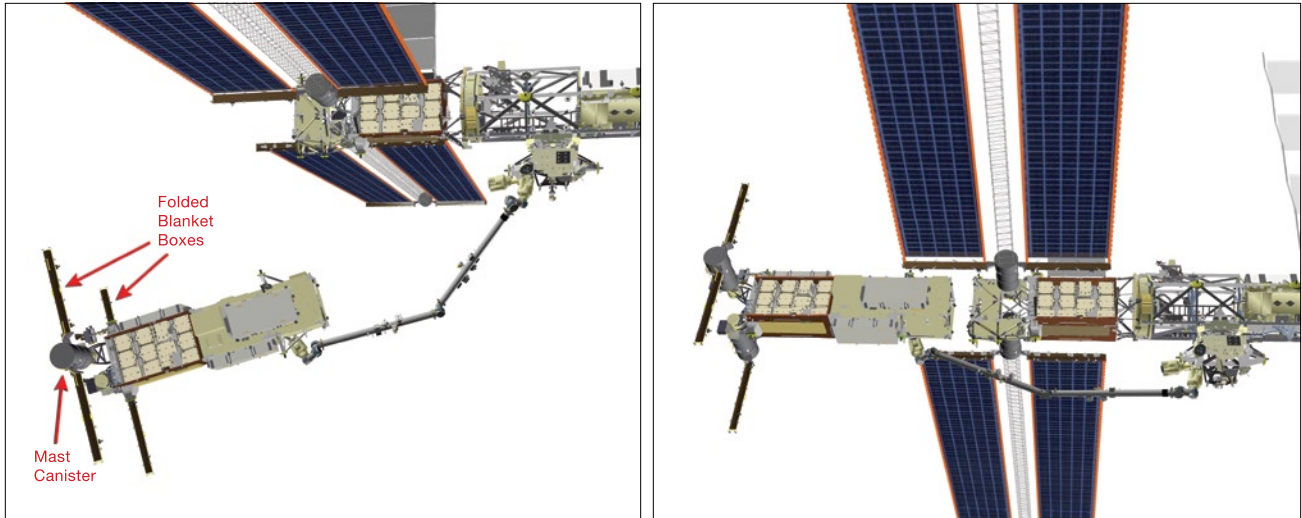
on the ISS after the many years they spent building their respective part of the station on the ground. The 10A mission and subsequent stage operations to move Node 2 to the forward position had to be completed prior to the much-anticipated shuttle mission carrying the ESA Columbus module, which was due to launch in December 2007.

Another key assembly objective was the transfer (relocation) of truss segment P6 from the central zenith (i.e., upper) part of the ISS, where

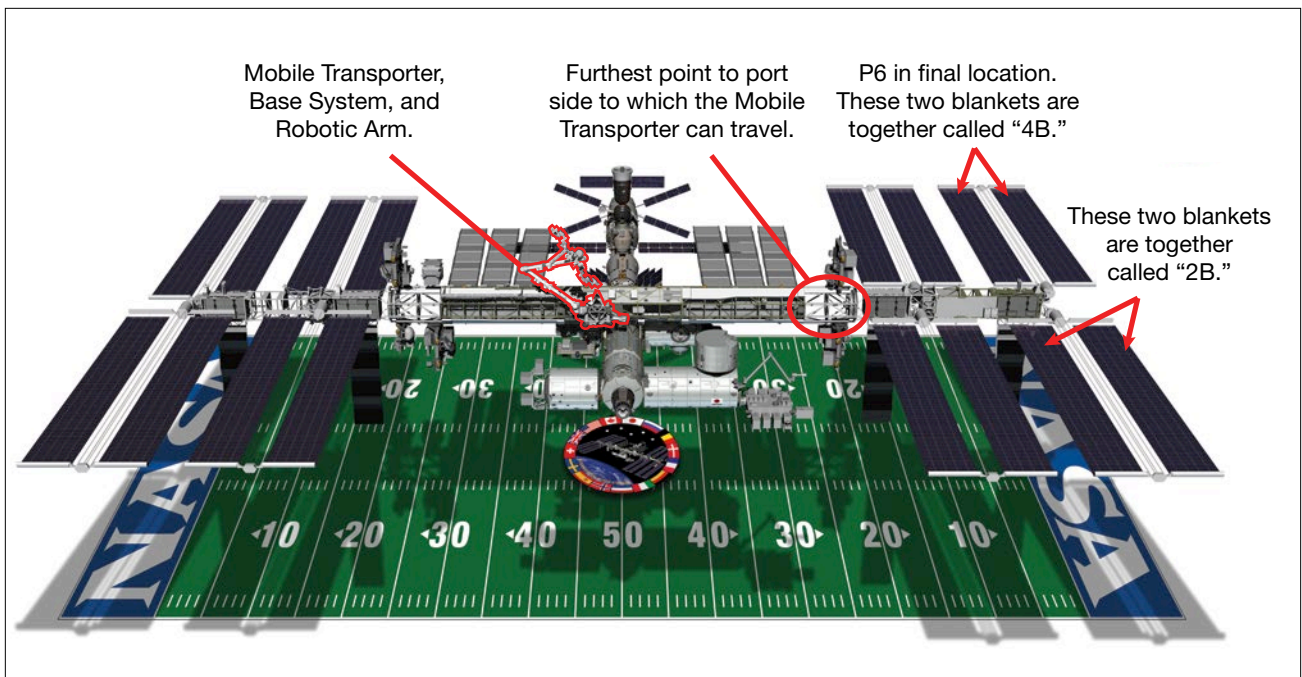
it had temporarily been placed for 7 years, to its final assembly-complete location at the far-port end of the truss (Figure 1). Prior to this mission, the large P6 solar array blankets had to be retracted (i.e., folded, accordion-style) so they would not sway or flap and possibly break when P6 was moved to the port side. During the STS-120 mission, the team would perform the robotic transfer and EVA bolting of P6 (Figure 2) onto the end, followed by commanding re-deploy of the arrays (Figure 3).



**Figure 1.** The ISS as seen from the Space Shuttle as it departed during STS-118, the mission immediately prior to STS-120. P6 is located in the center of the truss, with its solar arrays folded up in the long blanket boxes (as shown in the inset photo).



**Figure 2.** Graphic of the installation of the P6 module onto P5 during STS-120/ISS-10A. The solar arrays are folded up, accordion-style, in the long blanket boxes that are protruding from the cylindrical mast canister. Left image shows the P6 being maneuvered into position, whereas the right image shows it just prior to mating. Graphic generated using Johnson Space Center's Virtual Reality Laboratory software.



**Figure 3.** The huge solar arrays give the ISS an impressive wingspan, as seen here overlaid on an American football field. The Mobile Transporter is constrained to the middle truss sections by the large rotating Solar Array Alpha Joints. After the P6 truss module relocation to the far-port end of the ISS, the arrays are not accessible by an EVA crew member standing on the robotic arm due to the Mobile Transporter limitations. This lack of reach created a challenging circumstance during the STS-120 mission.

## Original Pre-Mission Spacewalk Planning

Most of the United States On-orbit Segment EVAs that occurred during ISS assembly were planned to occur during shuttle missions using shuttle crews, despite the fact that qualified spacewalking ISS crew members were constantly manning the ISS. This occurred for several reasons. First, the shuttle launched new ISS elements and pieces of hardware that usually needed specialized training for assembly or deploy choreography, and crews had to dedicate a lot of

time to study for some assembly EVAs. Training time was not as available for ISS crew members since they had an extensive multiyear training plan just to learn how to run the day-to-day operations on the ISS. This training included Russian language study and extensive international travel. Furthermore, ISS crew members were often committed to launching in a Russian Soyuz vehicle, and the Soyuz launch schedules were not typically tied directly to the shuttle launch schedule. In some cases, ISS crew members had used precious time to

train for shuttle-present EVAs, only to see shuttle missions moved out of their Expedition due to launch slips. As a result, assembly EVAs were assigned to shuttle crew members that would launch with the new elements. Shuttle crews performing these EVAs could dedicate a large amount of time training for EVAs, which meant greater efficiency during the tasks—e.g., less time was spent in space discussing the preferred location for a tether since crew members had already tried out a few locations while in training and decided upon the best approach.



**Figure 4.** The crew on orbit in the ISS during STS-120/ISS-10A: Top row: (left to right) Dan Tani, (extravehicular [EV] number 3, EV-3), Scott Parazynski (EV-1), Doug Wheelock (EV-2). Middle row: (left to right) Stephanie Wilson (robotic arm operator), Pam Melroy (shuttle commander and robotic arm operator), Paolo Nespoli (primary intravehicular [IV] crew member that aids the EVA crew during suit-up and the EVA). Bottom row: (left to right) Clay Anderson (ISS crew member), Peggy Whitson, (ISS commander, EV-4), Yuri Malenchenko (cosmonaut, EV-5), George Zamka, (robotic arm operator).

For these reasons, the STS-120 mission was initially planned with three spacewalks to be performed by crew members coming up in the shuttle (Figure 4).

- **EVA 1.** The first EVA was required to disconnect and prepare Node 2 so it could be robotically unberthed from the shuttle cargo bay using the Space Station Robotic Manipulator System. Also, the first of the truss element P6 connections were to be demated to allow for its later release from the central truss element Z1. Shuttle astronauts Scott Parazynski and Doug Wheelock (nickname “Wheels”) were trained to perform this EVA.
- **EVA 2.** The second EVA was needed to release the remaining connections and bolts for a final disconnect of P6 from Z1. This EVA was also needed to install critical exterior parts onto the outside of Node 2 before the operations in the stage and next shuttle missions. Parazynski and Dan Tani were trained to perform this EVA. Between EVAs 2 and 3, extensive robotic operations were needed to move the P6 segment close to its final location on the P5 truss.
- **EVA 3.** The third EVA was needed to align, bolt, and connect up P6 as well as ready a radiator for deploy. At the end of the third EVA, while the EVA crew was still outside, Mission Control Center-Houston would start deploying the radiator and P6 solar arrays 2B and 4B to begin generating power for ISS use. Shuttle astronauts Parazynski and Wheelock were trained to perform this EVA.

Several secondary objectives were included with the three EVAs. One task was to remove a failed antenna called the S-band Antenna Support Assembly, which weighed 103 kg (228 lbs), from the ISS and install the antenna in the shuttle cargo bay for return to the ground. The crew also took a new spare power distribution unit called a Main Bus Switching Unit, which is 238 kg (525 lbs), out of the cargo bay and placed it near the ISS airlock to be used in case of future failures of this type of unit. These operations and other tasks were built in as part of the three EVAs.

Originally, three other ISS EVAs were planned *after* the STS-120 mission. These EVAs were needed for the Node 2 move to its final location on the forward end of the laboratory. The ISS crew had been training for these “stage” (i.e., shuttle not present) EVAs. See the Introduction for more details about stage EVAs.

### Last-minute Spacewalks Added to the Mission Preflight

After the STS-120 mission was initially planned, the shuttle orbiters were changed from Atlantis to Discovery due to a delay in preparing Atlantis for flight. Discovery had been outfitted with the capability to draw power from the ISS after docking, thus the mission could be extended and the number of EVAs to be performed during the mission could be increased. EVAs during shuttle docked mission were advantageous because the

combined number of crew members on board would be 10 (seven shuttle, three ISS); therefore, more crew hours would be available to get the spacewalkers ready. The same strategy is discussed in Chapter 4 with respect to STS-130/ISS-20A.

As a result, in the spring of 2007, a pre-planned stage EVA by the ISS crew was moved into the shuttle docked time frame to bring the total number of EVAs during the mission to four. Two already-trained ISS crew members (Peggy Whitson and Yuri Malenchenko) would conduct this EVA. They would perform the EVA while the shuttle was present instead of after the shuttle departed. The team knew that if high-priority EVA tasks went long or new tasks were required during the shuttle docked time frame, the fourth planned spacewalk could be deferred until after shuttle departure. Whitson and Malenchenko, along with the required tools, would still be on board. The main purpose of this EVA was to get a step closer to the Columbus module mission by prepping for a robotic transfer of Pressurized Mating Adapter 2 to Node 2 and the eventual relocation of Node 2. The EVA crew would be demating connectors between the Pressurized Mating Adapter and the Laboratory, and removing a cover from Node 2.

After this change, and about a month prior to the flight, another spacewalk was developed and added to the mission in unusually quick fashion. This EVA was to be performed by Parazynski and Wheelock to test some material that could repair the Space Shuttle orbiter tiles, if damaged. Ever



since the Columbia accident in 2003, NASA had worked hard to develop a method to repair the delicate heat-dissipating tiles that protected the orbiter during reentry into the Earth's atmosphere. (This was in addition to wing leading edge repairs, which required different materials.) The tile repair material was a consistency somewhere between peanut butter and toothpaste. The crew would apply the repair material to damaged tiles, and the material would harden to the firmness of a pencil eraser and insulate (via specifically formulated properties) the orbiter during its super-heated reentry. This material was squirted out of a container called the Tile Repair Ablator Dispenser (T-RAD). The new EVA was labeled the T-RAD Detailed Test Objective.

Most EVAs are planned, preflight, over the course of months or even years; however, the operations team was asked to quickly finalize a tile repair test procedure because of the criticality of the test and the familiarity of the team and crew with the tile repair testing. A debris strike had damaged a tile during the STS-118/ISS-13A.1 mission that flew in August 2007. The level of speculation about tile repair capability prompted Space Shuttle Program management to conduct an official test as soon as possible. The team was able to develop this EVA within a few short weeks using some already-developed techniques that were familiar to the crew. Parzynski happened to be on the EVA Thermal Protection System repair collaborative team, as was the STS-120 lead EVA officer Dina Contella. Putting the experiment on this flight with quick turnaround was acceptable

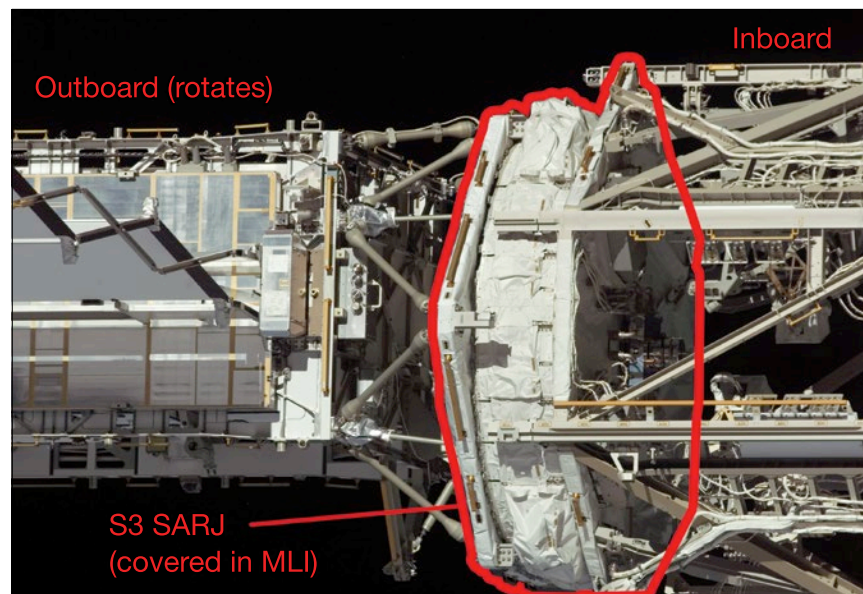
for the STS-120 operations team in terms of the limited training required. In fact, it seemed serendipitous that the team that worked so hard on creating this capability would get to execute the on-orbit test.

The team agreed to insert the tile repair test spacewalk after P6 installation (EVA 3) and before the increment crew Node 2 EVA. As discussed in Chapter 4, long missions with a number of spacewalks can be very tiring to the crew. This Detailed Test Objective EVA would be shorter than usual (4 hours) to better allow for spacewalks on back-to-back days without exhausting the crew.

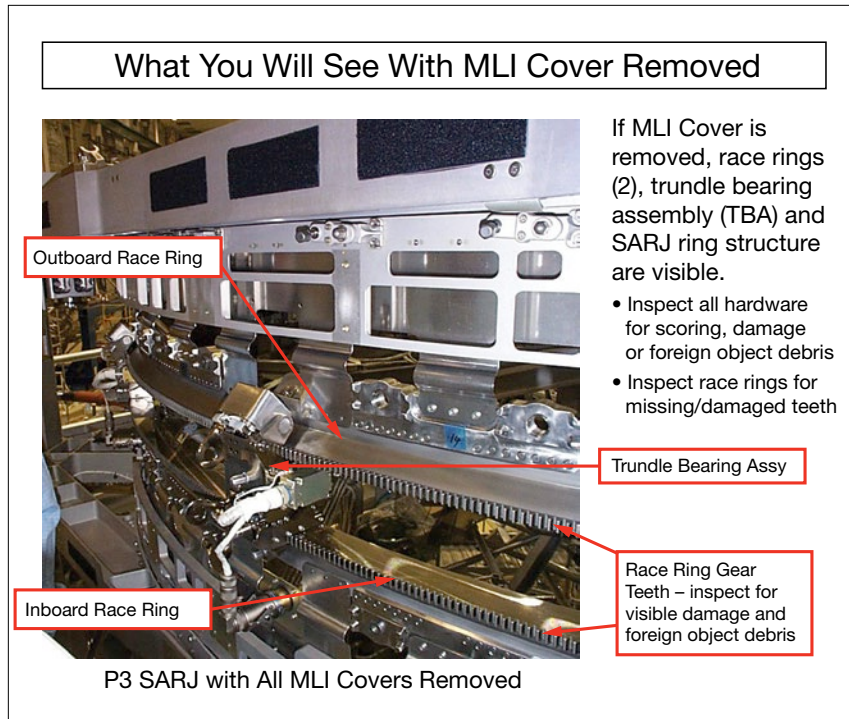
When Discovery lifted off on October 23, 2007, the spacewalks had evolved from the original three planned EVAs to five EVAs. It was to be the first ISS docked mission with five planned EVAs and the first mission with five different EVA crew members.

## Flight Days 1-3 (Tuesday, October 23 through Thursday, October 25)

STS-120 launched on Tuesday, October 23, 2007. The mission proceeded with a normal early mission timeline, including checkout of the spacesuits on October 24 (Flight Day 2). On October 25, the day the shuttle was performing a rendezvous with the ISS, the operations team was approached about adding a new EVA task to the mission to have the crew look at the starboard Solar Array Rotary Joint (SARJ) (Figure 5). This huge round gear measures 4 m (13 ft) in diameter and is driven by a motor to enable the solar arrays on the end of the truss to track the sun via rotation of the entire end of the truss. The engineering community had seen some slightly increased currents (~0.1 amp, with intermittent changes up to 0.8 amp) associated with the motor. Video indicated that the arrays



**Figure 5.** S3 SARJ (circled) rotates the outboard segments to point the solar arrays at the sun. The EVA crew was tasked with inspecting this SARJ to determine the source of increased motor current.



**Figure 6.** Instructional information that the Mission Control team sent up to the crew members to study before they performed an EVA to inspect the S3 SARJ. This SARJ hardware would be seen under the white multilayer insulation (MLI). Photo credit NASA-JSC/John Ray, taken at the Kennedy Space Center prior to S3 launch.

sometimes shook, as if there was increased friction somewhere on the circular travel surface or in a drive mechanism. It was speculated that this could be caused by a piece of thermal blanket that was dragging, the presence of foreign object debris (i.e., something that is not supposed to be there such as a piece of wire or washer), or something misaligned in one of two drive lock assemblies that houses the motor and lockdown mechanism. The starboard rotary joint had been on orbit a significantly less amount of time than the port side, which did not show any increased current; thus, age was not causing the starboard side to degrade.

The biggest concern was that friction would eventually increase to the point that either the motor couldn't overcome the force or the motor would fail, resulting in the inability to position the solar arrays. In addition to needing good array pointing to generate enough power, the arrays needed to be pointing in "safe" directions so they could endure the shaking and jet forces from visiting vehicle dockings and undockings (see Chapter 9). In fact, to ensure the arrays would be pointed in a good direction for the docking of Discovery, the team had preemptively "parked" (i.e., stopped rotation of) the starboard SARJ before the mission with the

arrays aligned in a position that would allow for the docking and also have adequate power generation for that time of year while minimizing potential wear and tear.

After so much speculation about what could be causing the SARJ issue, the engineering team wanted to have the EVA crew look at it. The flight control team worked with the SARJ hardware experts on an external inspection plan (Figure 6) and the removal of at least one protective panel to get a good look at the rolling surface and gears. Space Station Program management initially requested this to be a task for a later spacewalk, but the EVA team identified a good time frame in the middle of EVA 2, requiring deferral of only one lower-priority task to a later EVA. The flight control team was already adapting to the changing needs of the flight.

## Flight Days 4-5 (Friday, October 26 and Saturday, October 27)

EVA 1 was executed as planned. EVA crew members encountered relatively minor anomalies; e.g., some bolts were sticky (i.e., difficult to remove) and some ammonia ice flakes had floated out during the initial crew disconnection of P1 from Z1. As discussed in Chapters 4 and 17, the ground team had to track that the crew spent enough time baking out (i.e., allowing the ammonia to sublimate off of the suit) and had the crew members perform a test in the airlock to verify the absence of toxic quantities on their suits, which could

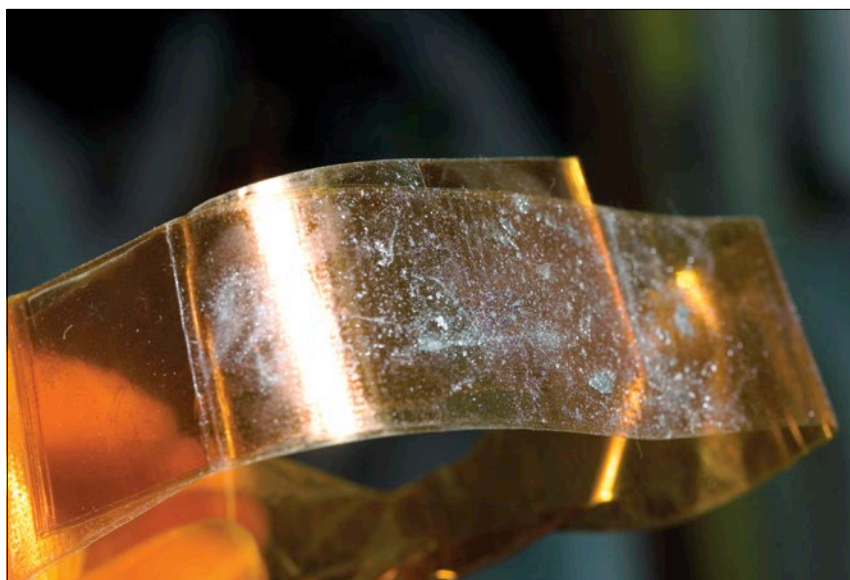
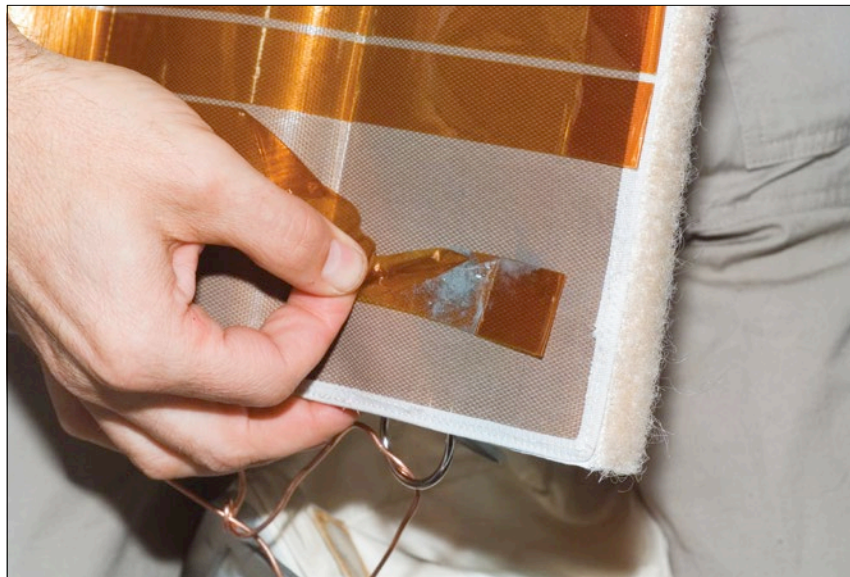
contaminate the ISS atmosphere. The Node 2 module was robotically moved out of the shuttle payload bay to its temporary location on the port side of Node 1. Applause erupted in the engineering room over this important new module for the ISS.

The day between EVAs 1 and 2 was spent preparing the suits and tools for the next EVA. This day also allowed time for the flight control team to get information to the crew members about their new task to inspect the SARJ and for the crew members to study the slightly altered choreography for the EVA.

### **Flight Days 6-7 (Sunday, October 28 and Monday, October 29)**

The flight control team had its hands full of small EVA surprises during the second spacewalk on October 28. Detaching the P6 truss segment went well, but some of the shorter planned tasks had to be cancelled (i.e., put into later EVAs) due to the issues encountered throughout the day. For example, the display locked up on Tani's spacesuit, and he had to perform a "reboot," as one would with a locked-up computer display. Also, the crew had difficulty operating some of the connectors, small o-rings floated out of some of the connectors, and a pin dislodged and couldn't be extracted from an area at a Node 2 berthing mechanism.

The starboard SARJ inspection revealed major news that would heavily affect the next few days. When Tani removed the cover, he saw what appeared to be magnetized



**Figure 7.** Photos of tape that the EVA 2 crew used to pick up metal particles seen on the SARJ. The tape was initially adhered to a caddy (top photo) that resembled a book with slick paper. The crew peeled the tape off of the caddy and made a loop with the sticky side out to pat the area and pick up the particles (bottom photo). The tape was put into a bag that came back down to the ground on the shuttle.

metal shavings on the passive ring of the SARJ (Figure 7). Shavings indicated pieces of the joint were grinding so hard that small metal pieces, also known as Foreign

Object Debris, were coming off and creating some amount of permanent damage. Tani's electronic still camera was not working, so the ground sent Parazynski to retrieve

a spare camera; however, *that one* did not work either! The live video from Tani's helmet camera was not detailed, but it was the best footage the ground team was going to get that day. The team had Parazynski gather a pouch with some adhesive tape while at the airlock. The crew was able to use the tape to pick up shaving samples by touching the adhesive side to the shavings. These could not be analyzed until they were brought home after the mission, but they would eventually allow the engineering team to identify the source of the material.

Before EVA 2 was even over, the operations and engineering teams were already thinking about what they could accomplish during this mission to continue searching for the root cause of the issue. Although the starboard SARJ could be positioned for this particular mission, analysis had not yet been completed to show there were adequate SARJ angles obtainable for the stage time frame after Discovery left and during the next shuttle mission that was planned for a few weeks later. The next mission would bring up the first ESA module: Columbus. Due to undesirable sun angles (called a "beta cutout," as discussed in Chapter 9) starting mid-December, having to add EVAs to the stage before that mission would likely push the Columbus launch significantly until after the sun angles became more favorable for both spacewalks and dockings.

A group called Team 4 was formed (see also Chapter 20) after EVA 2. Led by a flight director, Team 4 was tasked to assess whether it would be possible for the EVA crew to

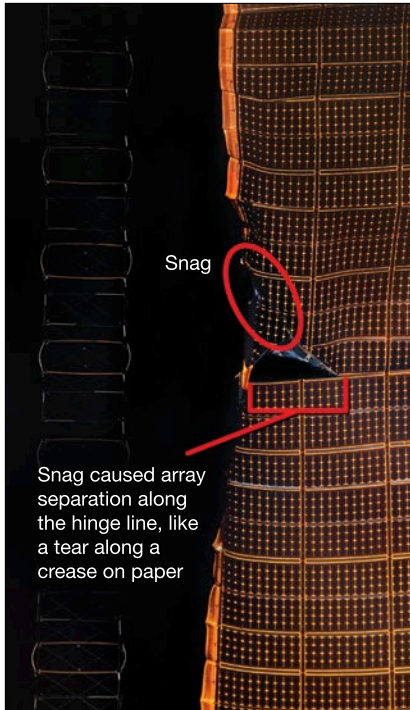
remove the 22 thermal covers that protected the SARJ and perform a detailed inspection of the entire SARJ to find the culprit hardware interference scraping the SARJ. This effort involved experts from across the country who were associated with the design and function of the SARJ, many of whom were also the solar array experts. The team quickly realized an inspection of this magnitude would take an entire EVA since the covers were bolted on and unbolting takes time. Team 4 started working around the clock on new SARJ inspection spacewalk procedures. The console team worked the overall plan to incorporate this EVA into the mission.

EVA 3 had to continue as planned on Flight Day 8 with the P6 segment released from the Z1 section and needing to be bolted onto the port end of the truss. The new SARJ spacewalk would have to take the place of either the tile repair experiment on EVA 4 or the stage EVA 5. This was an interesting trade because the Space Shuttle Program was highly motivated to complete the tile repair experiment that required shuttle hardware/tools, and which was to be stowed in the payload bay for return. The ISS Program needed to complete the high-priority stage tasks before the December launch of Columbus; otherwise, Node 2 would not be in the right place for the Columbus attachment. In the end, this interim debate was superfluous. None of these three EVAs (SARJ, tile, or stage) would occur during STS-120. The mission was about to encounter a major setback.

## **Flight Days 8-9 (Tuesday, October 30 and Wednesday, October 31)**

The EVA crew bolted on the P6 truss during EVA 3. The ground commanded the P6 arrays to slowly unfurl (i.e., deploy) from their folded-up condition (see Chapter 9) in a manner fairly similar to what had been done 7 years earlier on STS-97/ISS-4A. An array deploys via motor in the central mast, which lifts the top half of a blanket box, resulting in the unfolding of the arrays. This re-deploy was to be done during orbital day so that crew members could directly watch and command an abort if they saw that the array was not deploying nominally. Going into the mission, the team thought P6 deploy might be tricky since other array deploys had required real-time procedural changes or even EVA assistance in the past. The day after EVA 3 was planned as somewhat light to enable the team to work on slower or fancier deploy methods if needed, based on what the team saw during the initial deploy attempt of the P6 arrays. What actually happened was jaw-dropping, and completely unforeseen.

The 2B side managed to deploy without issues, but the team was able to deploy the 4B array only approximately 80% before a 0.6- to 0.9-m (2- to 3-ft) tear developed. Video showed that the array was torn along an accordion hinge line. Closer inspection revealed a smaller tear and a tangle in the guidewire that should have been assisting a smooth deploy (Figure 8). The flight control team sent a command to slowly retract the array just enough to relieve some tension so that the tear would not get



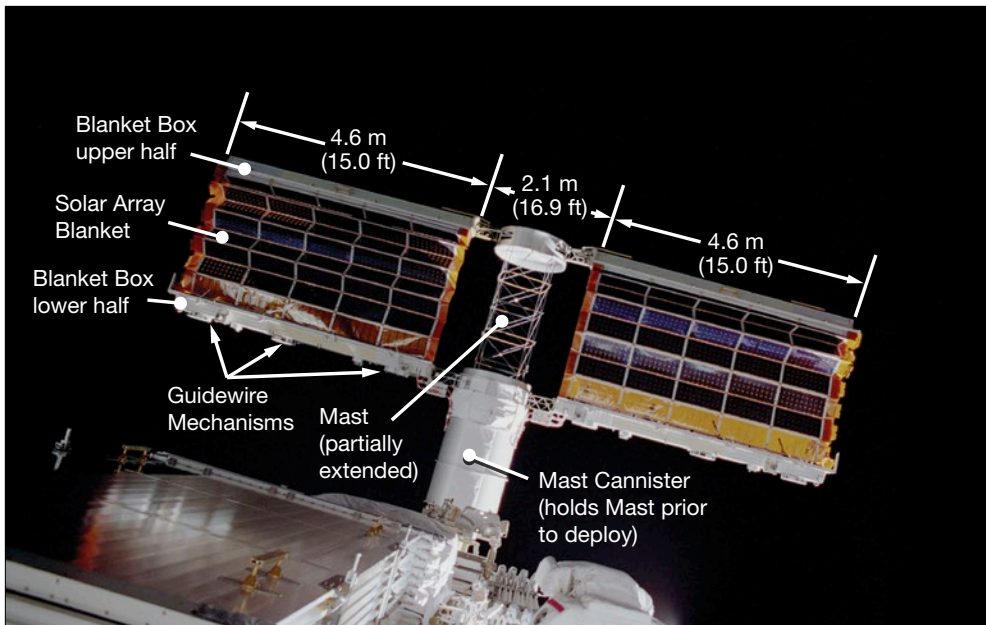
**Figure 8.** The 4B array damage. The crew and ground team aborted the deploy operation when the tear was noticed, thus the array did not get to the end of the deploy sequence where it would have been pulled taut.

worse. While the array was parked in this partially deployed state, the flight control team tried to determine what to do next.

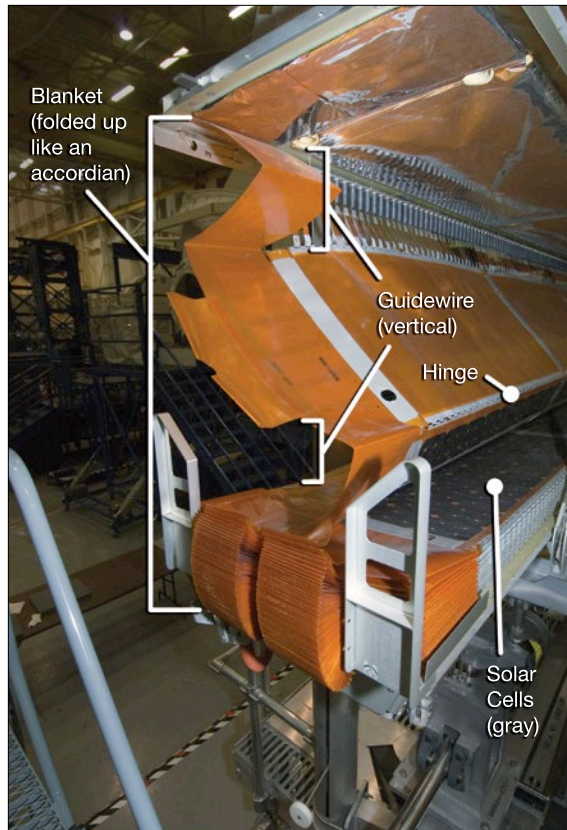
After looking at the video, it seemed clear the array could tear more if loads (i.e., forces) were put into it. One major concern was that vibrations and jet firings during the shuttle undocking or other visiting vehicles coming/going could cause the array to sway and rip further. It might not be repairable if it worsened. Further damage could lead to a need for the array to be jettisoned, meaning a future crew would have to dismantle it at the base and push the array to burn up into the atmosphere. This would present an extremely complex operation in which a jettison would leave the ISS with much-reduced power. Building another array would be costly. Future concerns aside, the near-term reality was that a ripped array could flap around and cause major damage to other components.

This issue became the top problem to solve on this mission.

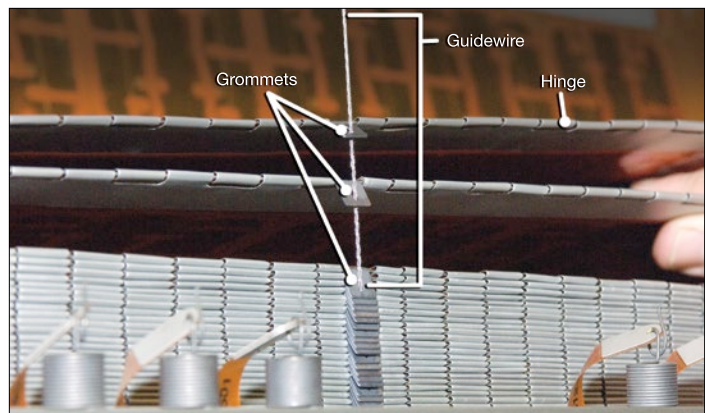
Solar array retractions and deploys in the past had sometimes required EVA crew assistance, as the mechanisms to unfurl large blankets of solar cells are fairly complex. The blankets are huge, with each array “wing” composed of two blankets—each approximately 35 m (115 ft) tall. The blankets were originally folded up in an accordion fashion inside a blanket box that was only 0.5 m (20 in.) tall. Often, a fold would stick to an adjacent fold when the blankets were later stretched out (Figures 9-11), or some part of the delicate mechanism would need the ground team’s creativity to jostle or pull it, or it would need an EVA crew member to carefully expand the array. The P6 arrays were not expected to be sticky since they had been deployed previously; however, the EVA crew had been trained, pre-mission, to handle other potential array issues



**Figure 9.** Solar Array Wing. Each array blanket was originally folded up, accordion-style, into a box. When the arrays were deployed, the boxes were commanded to unlatch, and the center mast that was folded up inside a canister was commanded to elongate. This effectively pulled the top half of the box (attached to the blanket) away from the bottom half of the box (attached to the other end of the blanket) and stretched out the folds in the blankets. (ISS Electrical Power Systems Training Manual - 01.04.05(0)T0005, Version 1.0, (supersedes TD9707))



**Figure 10.** A solar array blanket located in a ground facility. It is shown still mostly folded up in the lower half of the blanket box, as if the ground had just started to command a deployment. The active side of the array (shown) is where the solar cells (gray) are located to gather energy from the sun.



**Figure 11.** Passive side of the array (solar cells are on the other side of the array). The blankets are hinged. When they deploy, small grommets move up the guidewire. The guidewire keeps the blankets from swaying and bowing too much when the array is fully deployed.

such as freeing up small snags along the guidewires that help keep the array straight (Figures 11-12).

Team 4 and the console team were still working on the SARJ inspection EVA but had to start reprioritizing an array repair in short order. On Flight Day 9, the team decided to change EVA 4 from the SARJ EVA to a solar array repair EVA. Parzynski and Wheelock were chosen to perform the spacewalk, with Parzynski performing the repair since he was the most experienced EVA crew member on board.

## The Challenges

Repair of the array would be a high-degree-of-difficulty spacewalk if a fix was even possible. The flight control team did not have much time to create and execute such an EVA before the shuttle had to undock. Under the direction of the Team 4 flight director, multiple flight control and engineering teams—EVA, robotics, and power, to name a few—worked around the clock to identify each roadblock and devise a fix. Below are some of the challenges that the ground team and crew faced going into the EVA.

### 1. The Damage Might Be Just Out of Reach

The solar arrays were far, far away from the crew modules. P6 was no longer in the center of the truss as it was at the beginning of the mission. The most obvious technical issue was going to be reaching the damage. The snag could not be reached by an EVA crew member on the robotic arm, even with the arm fully outstretched. The team looked at the potential for retracting the array so the damage was near the base, but it was too risky to move the array that much. The damage could get worse, and

the accordion aspect could not be expected to work correctly.

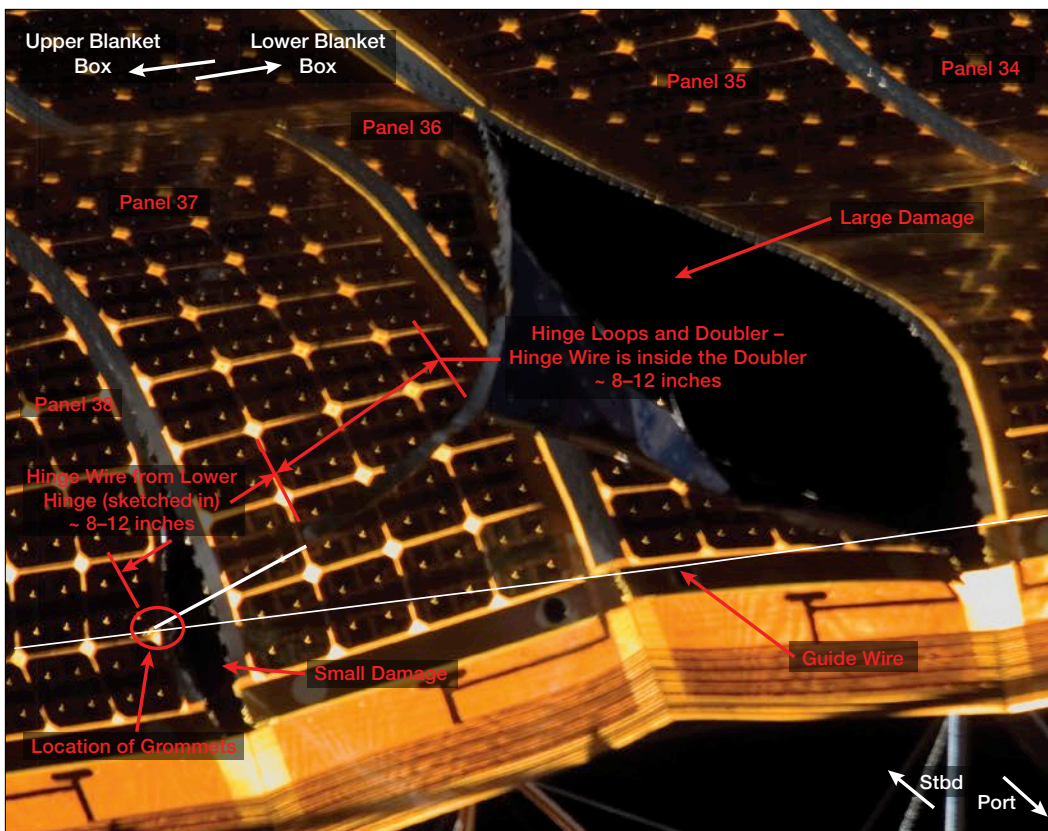
However, the Space Shuttle had a long 15 m (49.2 ft) boom called the Orbiter Boom Sensor System (OBSS) that the shuttle had been flying since the Columbia accident. The purpose of the OBSS was for up-close inspection of damage on the underside and wings of the orbiter. A shuttle EVA crew member could stand on the tip of the boom while the boom was grasped by a robotic arm to perform a repair. Use of the boom grasped by the ISS robotic arm (17.6 m [57.7 ft]) looked feasible for reaching the array damage—albeit barely—according to virtual reality and software models of the ISS. The ground team used this as the concept for the EVA.

The ground team set up the robotic systems ahead of the EVA, optimistic that the computer models were accurate in their conclusion that Parazynski could reach the array damage site. The team prepared for the EVA by translating the Mobile Transporter with the ISS robotic arm on it from the end of the truss to the center of the ISS. The SSRMS was now ready to take the OBSS out of the Discovery cargo bay. When the time came, the ISS arm would grasp the boom and the Mobile Transporter would move back to the end of the truss to point the tip of the boom toward the truss structure so that Parazynski could put his feet in a restraint at the tip for the ride out to the array. These complicated robotics operations were not pre-planned. A fairly large

effort was required to develop the procedures and perform the analysis to ensure the operation was safe.

## 2. The Damage Was Not Well Understood

Even with the most powerful zoom lenses, the damaged portion of the array was too far away from the crew inside the Space Shuttle and the ISS for a detailed look at the problem. Using the best crew-taken photos, the flight control team tried to map out the damage to the extent possible to develop a good repair (Figure 12). In the end, there were some “if you see this then do that” steps in the crew repair procedures on the day they performed the EVA. As always, the flight control team tried to prepare for every imaginable scenario.



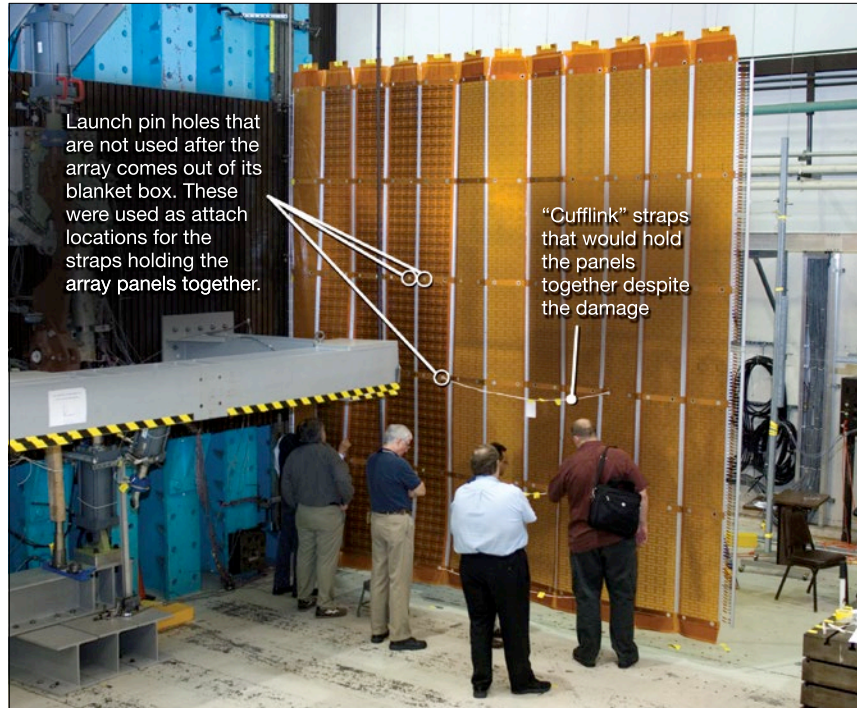
**Figure 12.**

*This was the best close-up photo of the damage available in the days prior to the EVA. The ground team marked it up with white lines and red markings, as shown, and uplinked it to the crew in this training documentation.*

### 3. Repair Materials Had To Be Crafted On Orbit

The solar array specialists, structural loads analysts, EVA team, and the crew's maintenance instructors tried to find any available materials on orbit that could clear a snarl of wires and permanently sew together the panels that had come apart at the hinges. Clearing or cutting the snag could likely be done using available US and Russian EVA tools; however, EVA tools would not do the trick for repairing the hinges.

Looking back, this effort was similar to the famous scene in the movie *Apollo 13* when ground controllers had to figure out how to build a carbon dioxide filter out of parts available to the crew. Using array parts on the ground and gathering a pile of various materials available inside the ISS, the flight control and engineering team came up with an ingenious solution. Special straps that could hold the panels together were proposed, taking advantage of intentionally designed holes on each side of the hinges (a thick pin was inserted into these holes to stabilize the arrays for launch, but the holes were not used after a standard array deploy). Five straps of three different lengths—89 to 165 cm (35 to 65 in.)—would hold the panels together the way tuxedo cufflinks work. Each end fed through a hole on opposite sides of the separated hinge lines. Crew members had to manufacture the straps out of a sheet of aluminum, some wire, and some tape. They cut the aluminum into 10 cm (4 in.) long and 2 cm (0.75 in.) wide strips, punched holes in the aluminum using a hand punch, created the specific length needed using 12-gauge wire, made an EVA



**Figure 13.** Hardware engineers and analysts discuss the repair during STS-120/ISS-10A while looking at the solar array ground unit. This photo provides some scale, when the array is compared to a human. A full Solar Array Wing would measure 35 m (115 ft) in length.

tether point, and wrapped everything in tape (see Chapter 16). The developed technique was then tested on the ground (Figures 13 and 14). The cufflink that was produced on orbit is shown in Figure 15.

### 4. Electric Shock and Sharp Edges Hazards

One of the most challenging aspects involved the safety of a spacewalking crew member working around the solar array. Unlike Orbital Replacement Units, which were discussed in the Introduction and Chapter 16, the arrays were not meant to be repaired by an EVA crew member. These arrays have sharp areas, which could puncture or cut the spacesuit. Plus, in this case, there were a lot of “unknowns” about the damage and what could

be sharp in that snag point. Most significantly, a solar array carries enough electric charge to electrocute the crew member in the spacesuit. Team members had to methodically think of everything that could lead to an electric current getting to the crew member, and to keep those scenarios from happening. The electrical power systems flight controller can reconfigure the electrical power system to reject energy from some areas, but no one can prevent the solar cells from becoming energized.

The concerns were numerous regarding the electrical aspect. Could crew members actually be electrocuted if they touched the damaged area? Could metal parts heat up and turn molten, such that a drop could come off and burn a hole in the spacesuit? Could





**Figure 14.** Repair technique development during STS-120/ISS-10A. Hinge stabilizing wires were called cufflinks because the crew would insert a thin 10 cm (4 in.) long aluminum plate through a hole, where it would catch on the other side. This plate was attached via a long wire to another plate that the crew would also thread through the array and into a hole on the other side of the damaged hinge. The first two figures show the insertion technique. The third photo shows the backside, where the wire is not visible but the aluminum plates are seen flat against the array. In the last photo, astronaut Steve Swanson tries out the technique while wearing an EVA glove to test whether Parazynski will be able to perform the technique while suited in the Extravehicular Mobility Unit.



**Figure 15.** STS-120 pilot George Zamka holds up a cufflink that he and ISS Commander Peggy Whitson constructed on orbit in preparation for the 4B solar repair EVA.

sparking/arcing occur and jump between the array and tools or the suit? Could the energized “plasma” environment of the ISS in its orbit aid in this arcing? Was there a better time to perform the repair relative to orbital sunrise/sunset to reduce the risk of shock—and how does wait time in the orbit trade against the risk of having Parazynski remain near the array while waiting for the perfect conditions?

Because sunlight reflects off of the Earth and the ISS, the array could be energized even during orbital night. The team quickly decided the crew would only work from the passive side of the array (solar cells facing away from the crew). That did not avoid the danger completely—the array damage could still point part of a cell toward the crew member, exposing him to an electric charge. Parazynski’s huge suit or his floating tools might accidentally come in contact with the damage, especially if the array was swaying while he attempted to enact the repair. The team could imagine having him cut a wire and releasing some stored energy that would “twang” or oscillate and move the array.

Various experts on electrical shock and plasma weighed in. The EVA console brought in safety experts to brief the EVA team on the hazard and how to prevent it. They were told the path to shocking the crew could be as follows: a hot (i.e., electrically energized) part of the array comes in contact with a metal tool, the tool touches a metal part of the suit such as the hard wrist connection, the astronaut touches the same part on the inside of the suit and is sweaty, another sweaty body part touches another metal part of the suit such as the waist bearing, and that metal part touches a grounded part of the array such as a guidewire. This scenario would result in an electric current traveling through the astronaut's body. The EVA team relayed this information to the crew, via private video conference, to make sure everyone understood the hazards.

The team went about ensuring this chain of events would not be possible. Parts of the suit and the tools were taped with insulating Kapton orange tape. The tape would keep electric charge from conducting between the array and the tool. Also, the ground had the crew tape up the metal wrist area of the Extravehicular Mobility Unit where the gloves attached. The number of tools Parazynski had with him was kept to a bare minimum, which provided a better chance of preventing tools from floating into the array.

One question was whether sparks could jump through space, similar to lightning, if electrical charge differences were present. Although there is very little atmosphere at the altitude of the space station, charged particles surround the Earth. Plasma Contactor Units on board the ISS are turned on for spacewalks to

specifically emit electrons into space. This creates a "grounding strap" and helps avoid the buildup of a large difference in electrical potential between the ISS structure and the surrounding environment. These units would be used, but would they be enough to mitigate the risk? As it turned out, the time of year was favorable and the solar cycle was closer to a minimum level of activity, so there would not be as many charged particles at the ISS altitude to create the plasma that would allow for a significant jumping of sparks/arcs through space.

Current flows from the array cells to the edges of the arrays, and then down to the base, with more and more current built up closer to the base after gathering input from cells along the way down. With the damage more than halfway up the array, the voltage and current of the specific area was known. The team determined that a spark could not jump more than about half an inch between electrically hot spots on the array; therefore, a jump between the array and Parazynski's metal neck ring on the suit was not possible as long as he kept the array at a comfortable distance. Parazynski might expect to see some small arcs, but they wouldn't jump across free space to him. Furthermore, the creation of molten metal would require a much greater level of energy than deemed possible, considering where Parazynski could potentially come in contact and the fact that the tools were taped up.

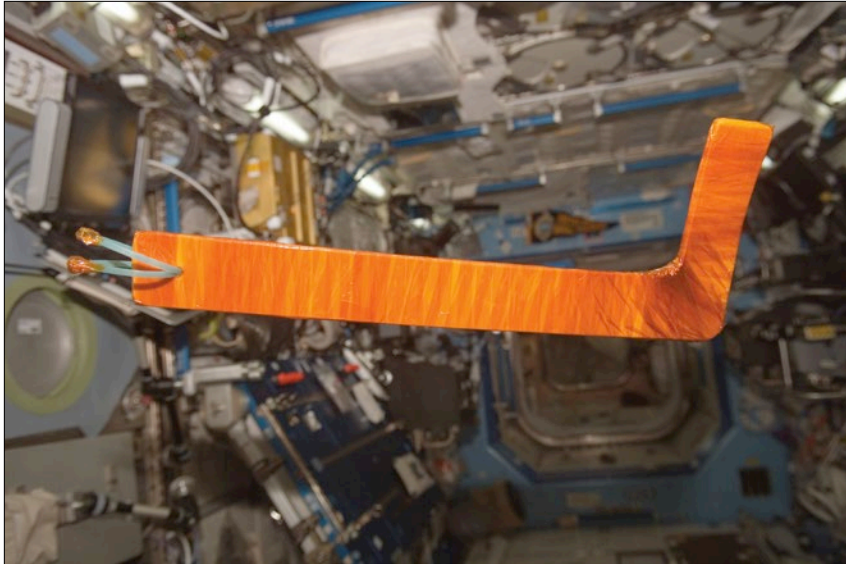
Many sharp areas on the array could nick a glove, or many areas could be energized. Parazynski was told not to touch the array with his gloved hand. Instead, he had with him a tool that had been built inside the ISS, a

few months prior, to keep a swaying array from contacting a crew member during an EVA on an earlier mission. This tool, called the hockey stick, was made of nonconductive material wrapped in Kapton tape. The hockey stick could be used as a defense to push the array away if it came near (Figure 16). Vibrations, pushing, or the act of the repair could cause the array to flap and move, like a sail in the wind. This complicated the repair because Parazynski needed to keep the array close enough to perform the repair, yet keep the array at a distance using the hockey stick—all the while trying to enact the repair and holding additional tools.

### ***5. The Boom Might Be Too Bouncy***

The plan was to have the ISS robotic arm grasp the boom at its center, with Parazynski standing in a foot restraint on a Worksite Interface (WIF) Extender, which would add approximately 0.9 to 1.2 m (~3 to 4 ft) to the overall reach to the damage site. He would essentially be on the end of an approximately 27 m (90 ft) pole. Movement of his spacesuit could cause ups and downs like a fish caught at the end of a fishing pole. The team had concerns about how much Parazynski would bounce around after making small movements and his ability to avoid smashing into the array, inadvertently. Imagine trying to perform delicate surgery while bouncing on a trampoline. Not easy to accomplish!

Although the Space Shuttle boom had not been intended for the purpose of getting a crew member close to a dangerous solar array, the STS-121/ISS-ULF1.1 crew in July 2006 had performed testing while standing on a foot restraint attached directly to



**Figure 16.** The team took advantage of a previously constructed tool called the hockey stick, due to its shape. It was not as large as a hockey stick, however. It measured 46 by 18 cm (18 by 7 in.). Parazynski could use it as a defensive tool if the array swayed near him, since it was made of nonconductive material. He would tether to the blue tie wrap loops (redundant in case one of them broke) and hold the stick near the end with the tethers. The shorter part of the “L” could be used to push the array away if it got too close. The hockey stick is shown floating in the laboratory during Expedition 15.

the tip of the boom (i.e., without a WIF Extender). The test was intended to prove that an astronaut could stand at the tip of a long boom on the shuttle robotic arm to repair the shuttle, since it was theorized that the boom would feel bouncy and move quite a bit as the astronaut moved his or her heavy spacesuit. In the case of STS-121, the shuttle robotic arm grasped the end of the boom.

The proposed configuration for the solar array repair was with a stronger robotic arm—the ISS robotic arm—grasping the middle instead of the end. Although the configuration was not tested at these specific arm angles with this arm and WIF Extender, it was hoped that Parazynski could perform his work safely despite some bounciness in the system. Team members tested the configuration using software in the Virtual Reality laboratory just to be sure. They

crafted into the EVA a small test—the ground team planned to have Parazynski lean in and get a feel for the bounciness of his platform before starting the repair work.

### 6. The Airlock Would Be Far Away

Typically, EVAs are choreographed such that an EVA crew member could get back to the airlock within 30 minutes in an emergency. If, for example, the fan/pump/water separator unit in the spacesuit (see Chapter 17) were to stop working, the EVA crew member could open a valve in the suit to help with cooling. In a worst-case scenario, the suit would have enough oxygen for 30 minutes in which the crew member would return to the airlock while the suit expended oxygen through the valve.

In this case, it was initially estimated that it would take Parazynski up to an hour to get back to the airlock in

an emergency. This was eventually refined down to 30 to 45 minutes by planning where he would tether himself, having a quick robotic maneuver to the truss ready to go, and making sure the on-board crew was ready for such a scenario. But, because of the critical ISS need to have this repair done, additional risk had to be accepted when sending Parazynski that far from the airlock.

This risk was debated extensively in Team 4 and program meetings since standard crew safety practices would have to be waived to accomplish the task. The 30-minute emergency airlock ingress constraint was used throughout the ISS assembly and was the basis of many decisions related to operations and hardware design to avoid delaying crew members if they needed a quick translation back. Therefore, accepting this crew risk was not taken lightly.

One of the factors in accepting the risk was that 30 minutes is often not an exact number when it comes to EVA. For example, in this case, there might be some extra oxygen in the main tanks, there might be less tethers than normal to disconnect to start the return, and Parazynski was highly experienced. Inherently, spaceflight requires taking risks. The final decision was that this situation was deemed worthy of the elevated risk, with the operations team making sure an emergency return was very well planned to be as efficient as possible, should a spacesuit failure occur when Parazynski was far from the airlock.

### 7. The Boom Sensors Might Break

Using the ISS robotic arm to grab the boom instead using of the shuttle robotic arm would cause the delicate

high-tech imaging sensors at the tip to be unpowered for several hours. The worry was that the sensors would get too cold and become damaged, resulting in the inability to inspect the thermal protection system of the shuttle prior to reentry. The ability to perform inspections became important after the Space Shuttle Columbia accident. The shuttle mission management team had to carefully

consider the possibility that this operation might break these sensors.

Initially, the team estimated the boom sensors would be unpowered for 12 hours, with the sensors getting too cold after being unplugged between 5 and 8 hours. The robotics plan was changed so that the shuttle robotic arm would hold the boom for some of the preparations, thereby

reducing the exposure to around a predicted 8 hours. After looking at the environment, the analysts concluded it might remain warm enough to prevent the sensors from becoming damaged. Because of the criticality of the boom usage for this repair and some conservatism in the thermal analysis, the mission management team agreed to use the boom. They accepted the risk that these sensors

## Chance Favors the Prepared Mind

*Colonel Doug Wheelock*

*STS-120/ISS-10A and Expedition 24/25*

The inside of a spaceship offers a level of normalcy. The temperature and atmospheric pressure are fairly constant. It is easy to get lulled into a false sense of safety. But the moment you open the hatch, the rules change. Oblivion resides on the other side of your thin helmet visor. You are now engulfed in a dangerous environment of chance. And, as we know, chance favors the prepared mind.

During our 18 months of intensive training, Scott Parazynski and I worked diligently in NASA's Neutral Buoyancy Laboratory and Virtual Reality Laboratory. We did whatever we could, as many times as we could, to replicate the spacewalking environment, talking through every conceivable contingency. I grew up hearing the mantra "Practice makes Perfect." However, when preparing for spaceflight, that mantra is more accurately "Perfect Practice makes Perfect." No room for error, and complacency is met swiftly with dreadful consequence.

The moment arrived for my first spacewalk. With the reduced pressure inside the suit, I could hear a difference in my voice, which gets deeper at the lower pressure. Scott opened the hatch and said, "Oh wow! Wait until you see this, Wheels! We're over the Himalayas!"

Nothing quite compares to that first step out into the vast universe. Your home planet is far beneath your feet. Everything and everyone you have ever known...all on that blue planet. And you're not there. The feeling is quite profound, and difficult to put into words. Space is visually

spectacular and completely breathtaking because of our blue planet. It is an explosion of color in the sunlight, an oasis of motion and light, suspended in an empty sea of darkness. You feel vulnerable. Fragile. Fear is your constant companion. The Earth is distracting from this vantage point. It is difficult to stay focused, but you have to get back to work.

My second EVA was amazing, bolting down the nearly 19-ton P-6 truss and solar arrays to the far port end of the ISS truss. We finished the task and returned to the airlock. Our team worked through the deployment commands for the solar arrays. Scott and I were cleaning up when the "abort" command was broadcast. I knew that couldn't be good, but I had no idea how that moment would shape my life and work, as well as teach me lessons about leadership, teamwork, and perseverance that have changed who I am as an astronaut and leader.

The solar array got snagged by a frayed guidewire, and the situation was dire. The next few days were full of confusion, doubt, and despair. How could we ever repair a torn array? Hours and hours passed. We talked about what was likely going on down in Mission Control in Houston. We were sure NASA had pulled out all the stops to help us fix the station and get us home safely. I remember talking with Scott in the intervening days about how it felt like Apollo 13. I had worked at NASA for 11 years at this point. A calm assurance washed over me in that moment. I realized that the reason it was so quiet on the voice loops was because they were testing a potential solution. I knew in my heart that some sharp engineer turned to our team and said, "Hey...what if...?" I knew that one day we would look back and remember this as one of NASA's finest hours.

might not survive, which would result in an inability to check the thermal protection system of the shuttle before reentry into Earth's atmosphere.

### **8. Spacesuit Failures**

A hole was discovered in the outer layer of Wheelock's right glove at the end of the third spacewalk. Wheelock's gloves were changed

out with a backup pair for the next EVA, but the team questioned whether something sharp outside could puncture a hole in a glove during this upcoming EVA, possibly even creating a hole into the bladder of the suit and springing an oxygen leak. Several items that were theorized could cause the issue, but nothing was the obvious source. One leading suspect was a pair of

foot restraints with difficult-to-turn knobs—they possibly had a defect or micrometeoroid orbital debris had damaged them. The team wanted to bring those inside, if possible, on this repair EVA for inspection. In the meantime, how could the team ensure the crew would stay safe from sharp edges? This was one more complicating factor that had to be discussed at length before the EVA.

Sure enough, our next video conference with our team on Earth involved a box full of makeshift parts, fashioned together and dumped out on a table, just like in the movies! They explained what we were going to do. They gave us vectors on where to find cable, pieces of metal, and sheet metal tools needed to build "cufflinks" to sew the torn solar array. Though years have slipped by since that day, it still amazes me that someone thought of this solution. It made me grateful to be alive, and grateful to be part of the NASA team. The plan was full of danger and unknowns. We taped everything metal on our spacesuits, including the neckring of our helmets, which really got my attention. I was going to be responsible for keeping Scott safely clear of the billowing array, so it wouldn't fry the electronics in his suit and electrocute him. I was also responsible for feeding the guidewire cleanly into the inertial reel, while maintaining control of the wire. The engineers told me to keep my suit clear of the wire, since it retracts at 10 feet per second. They were concerned that if I lost control of the wire, it would tear through the solar array and even through my suit! Trust me, they had my undivided attention!

It was game day, November 3, 2007. Scott was stoic and focused. I was full of fear, but if I was purposed and methodical, I would increase my chances of success. There is a saying we have in the astronaut corps, that there is no situation in space so bad that you can't make it worse. Spacewalking demands a balanced level of logic and impulse, and the clear recognition of danger.

When I exited the airlock, I felt like a machine. I knew what I had to do, and I wanted to get on with it while adrenaline still coursed through my veins. Mission Control told us

they were going to maneuver the ISS to shadow as much of the array as they could to reduce the electrical power generation of the arrays, resulting in me being in shadow for the next 7+ hours. Scott was in position to cut the frayed part of the guidewire. I reached inside of the array with the needle-nose pliers to control the guidewire and give Scott a "go." I held a metal tool mere inches away from the array power strip that carried 200 amps of current, and I was a bit nervous. But, everything went smoothly and the cable retracted fully into the inertial reel well.

Scott finished installing the five cufflinks. We were ready to clear the area. The robotic arm operator maneuvered Scott away from the array and back to structure. I was asked to return to the airlock. By this time, my teeth were chattering and I couldn't wrap my fingers around anything. My heart was pounding, and I had to figure out a way to warm my hands. I noticed a sliver of sunlight on the top of the mast canister, so I crept up the mast and stuck my hands into the sunlight. It took a couple minutes, but my hands warmed enough to grip the handrails and my tools, and make my way back to the airlock.

Our repair worked! The array fully deployed, and the cufflinks are still holding to this day, years later.

Now when I am asked what it is like to do a spacewalk, the answer is not so simple. It is mentally and psychologically the toughest yet most rewarding work I have ever been a part of. I have never felt more mortal than when I was out on a spacewalk. I have never felt as cold as I did that day in November 2007. But the sense of pride I will feel to the end of my days, of being a part of something great, is overwhelming.

A set of “overgloves” was planned into the EVA to provide for this sort of protection. Overgloves were mittens that fit over the index finger and thumb and covered the most-used glove areas. They were somewhat loose, thereby reducing the overall dexterity of the crew member’s hands even more than the spacesuit gloves. The team members expressed many concerns about using overgloves when doing fine detailed EVA work—they didn’t want Parazynski unable to perform the repair, snagging the overglove, or having hand fatigue. It was agreed that both Parazynski and Wheelock would wear these gloves, but when Parazynski got on the tip of the boom, he would remove his overgloves to perform the repair.

Also on EVA 3, Parazynski’s spacesuit exhibited increasing temperatures due to a theorized failure of his sublimator (the component that rejects heat). The team declared his primary suit “no-go” for use on this upcoming EVA. The crew had to spend extra time to size a different spare suit to fit him.

### **9. Lack of Time**

To pull off this kind of repair spacewalk could take weeks of preparation in various ground facilities; however, only a handful of days remained before the shuttle would run out of consumables and have to depart. Even simple EVAs are usually trained in the Neutral Buoyancy Laboratory several times before attempted in space. With so little time, a lot of “gut feel” from engineers, flight controllers, and experienced crew would have to be used to assess robotic motions and unknown array dynamics during the repair. Unfortunately, the same

people who had worked so hard (i.e., electrical power experts, EVA teams), day and night, to come up with the SARJ EVA had to now work the solar array issue day and night until it was fixed.

The array snag occurred on Tuesday, October 30, after EVA 3. On Wednesday, the team changed direction, completely dropping all work on the SARJ and instead working exclusively on the repair EVA. Highly optimistic thinking put the repair EVA on Friday, with a second EVA possible before undocking. Everyone felt the pressure to perform a successful repair before the shuttle and its boom departed.

### **Flight Day 10 (Thursday, November 1)**

As Friday approached, flight controllers worked around the clock (many working 12 hours or more at a time), and things were coming together the night before the spacewalk. Almost. The team struggled to get the final procedures on board, the console positions in mission control were not feeling ready, and the team working the repair EVA details was exhausted. The flight directors involved recognized these clues as “links in the error chain” building up. Accident investigations often point at links in the error chain where a series of events led to the accident—if any one event had been recognized and stopped, the accident could have been prevented. In this case, the team was not meeting all of the deadlines, and people were heads-down writing the details to the point of not looking ahead to keep important big-picture

issues in mind. Flight controllers might have pulled off the EVA that Friday, but that sick feeling that everything was not under control meant an error chain was perhaps developing. The team needed one more day. The flight directors and program management agreed to move the EVA from Friday to Saturday. This meant the array had to be repaired on a single EVA—no falling back on a second EVA since there would not be time for a follow-on EVA before the shuttle would have to undock with its remaining consumables to make it home.

### **Flight Day 11 (Friday, November 2)**

With the EVA now scheduled for Saturday, the final conferences were conducted on Friday with the crew to discuss the repair details and robotics. EVA crew members had procedures on board that they printed out and taped to their cuff checklist so that Parazynski would have a graphic representation of where he would install the cufflinks (Figures 17-19). Tani and Wilson would be the station robotics crew members, and they had procedures on board and were feeling ready.

The general order of events was to be as follows:

1. The IV crew would robotically position the tip of the boom near the port side of the truss, ready for the EV crew.
2. The EV crew would install the WIF Extender and a foot restraint onto the tip of the boom, and Parazynski would put his feet into the foot restraint.

3. The IV crew would robotically move Parazynski to the damage while Wheelock translated “free-float” (i.e., using his hands, grabbing handrails) to the base of the array to help provide clearance calls to Parazynski about his distance to the array.
4. Parazynski would install the first cufflink to carry some load in case the array started moving significantly.
5. Parazynski would clear the snag using his best judgment by pulling parts of it free using pliers, flicking small parts using a spatula, or trimming a hinge wire. Among other tools, he had with him a pair of borrowed Russian cutters called “dinocutters,” due to the dinosaur-like shape of them.
6. Only if necessary, Parazynski would cut out the snag by cutting the long vertical guidewire and allowing it to retract into a spooled reel at the base of the array where Wheelock would ensure a good feed into the reel. There was a concern that it would have trouble reeling in and snag some more; therefore, the team had contingency procedures developed in case of additional loose wire to deal with. After the snag was in Parazynski’s trash bag, this would leave the top of the guidewire free, which was deemed acceptable.
7. Parazynski would shape the array back into a loosely accordion shape.
8. Parazynski would install the other four cufflinks.
9. Mission Control would command the array deploy very slowly with the crew watching (and the helmet camera sending back live in-situ video).



**Figures 17.** High-level instructions sent to the crew based on the imagery available. Detailed procedures were also sent up.

WARNING

1. Sharp edges:
  - a. SABB (skirt, swing bolts)
  - b. Solar cells
  - c. Springs along tension bar
  - d. Panel hinges
  - e. Guide cable burrs or frays
  - f. Mast Canister roller guides
  - g. Braided cables
  - h. Fastener exposed threads
  - i. Exposed bolts in rib cavities on mast canister
2. Shock hazard:
  - a. Avoid EMU contact with FCC and Kapton part of solar array panels
  - b. EV crew will only contact energized surfaces with approved tools that have been insulated with Kapton tape to prevent molten metal and shock
  - c. Solar array to be manipulated will be shunted prior to EV crew entering worksite
3. Pinch:
  - a. Lower SABB exposed reels and pulleys (guide wire and tensioning mechanisms)
  - b. Solar array mast during deploy/retraction
4. Avoid inadvertent contact with:
  - a. SSU, ECU, beta gimbal platform, mast canister, SAW blanket boxes unless the beta gimbal is locked and the motor is turned off

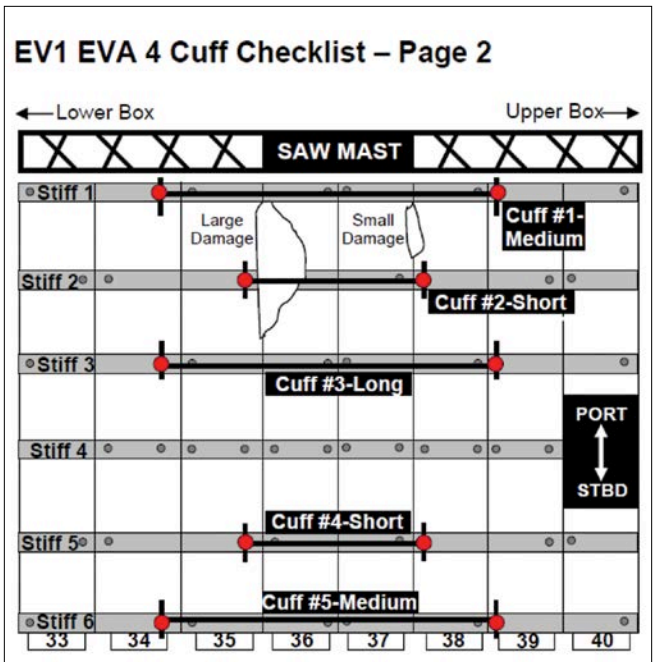
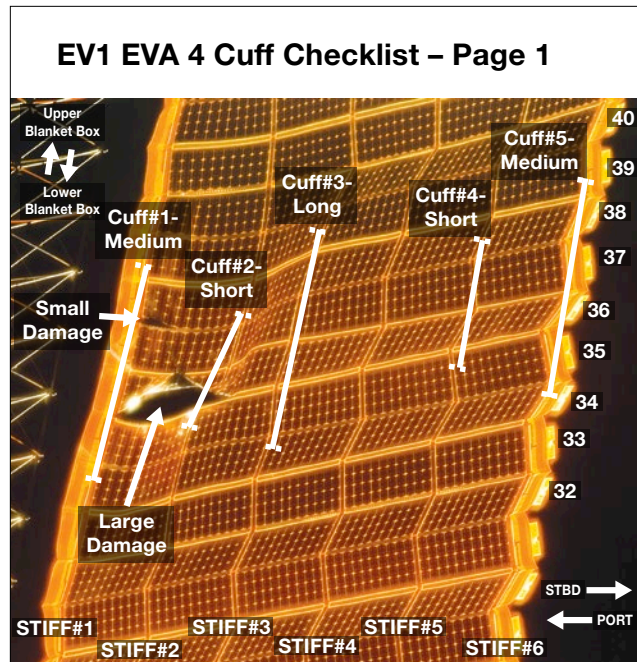
WARNING

1. Verify glove gauntlets cover wrist disconnects

WARNING

Minimize contact between metal array components and exposed damaged solar cells on active side. Note some sparking may be expected.  
 Avoid contact with solar panels except with insulated tools.  
 Sharp edges likely present at damage locations.

**Figure 18.** Detailed warnings sent up to crew to study in advance of the EVA.  
 (SABB = Solar Array Blanket Box; EMU = Extravehicular Mobility Unit; FCC = Flat Collector Circuit; SSU = Sequential Shunt Unit; ECU = Electronics Control Unit; SAW = Solar Array Wing)



**Figure 19.** Graphics that the crew printed out on board and taped to Parazynski's cuff checklist. He could look down at his wrist to make sure he knew exactly where each end of each cufflink was installed. The nomenclature "stiff" refers to strips of material called "stiffeners" that run the length of the blankets, somewhat helping to rigidize the array. These and the bay numbers 32 through 40 were there to help the control center and crew have a common nomenclature if they noted an issue with a particular area. None of the bay numbers were physically marked on the arrays.



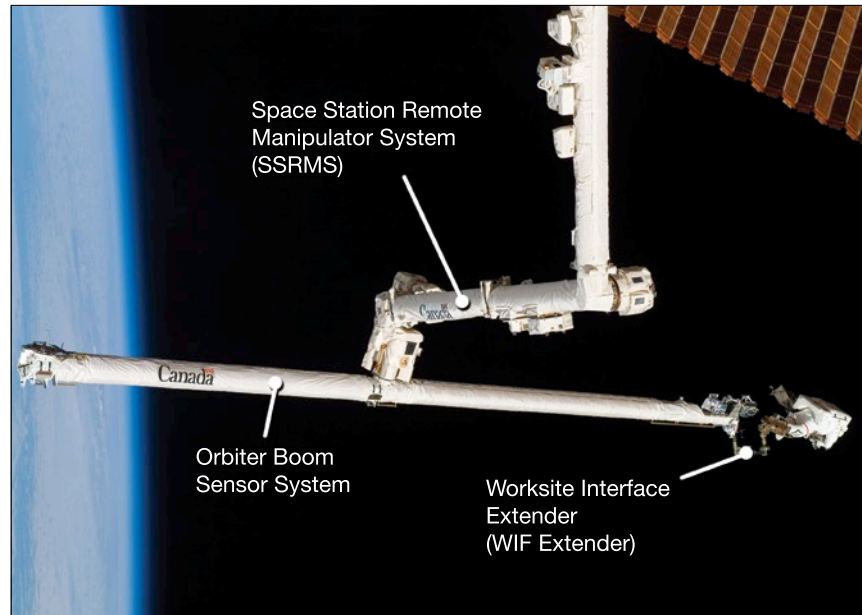
## Flight Day 12 (Saturday, November 3) – Solar Array Repair Extravehicular Activity Day

The EVA was pretty spectacular.

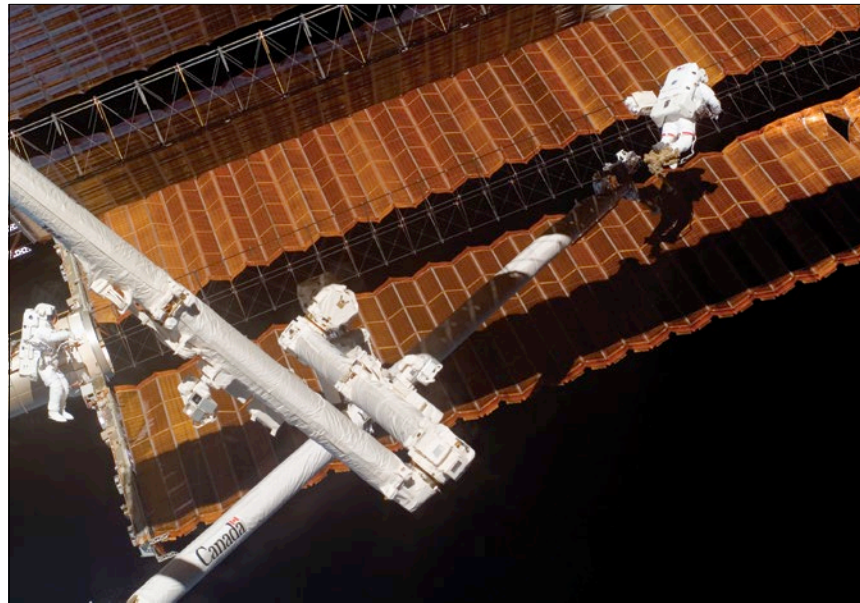
When the EVA crew members went out to the truss, they found the boom was fairly stable (Figure 20). The tip was positioned farther from the truss than it would normally be so as to not impact the truss, which created some challenging moments. The EVA crew members had to assist each other in getting back and forth to the tip, even crawling on one another's backpack for reach (showing that even when meticulously planned, the crew and flight control team still need to adapt). The WIF Extender on the tip of the boom resulted in some flex, but the crew found it manageable.

Parazynski had an incredible 40-minute ride to the damage site, with sweeping views of the ISS from a distance. Upon arrival, he described the damage for the ground team and called it a “hair ball.” Based on this description, the team knew it would require the more complex of the repairs envisioned, and he would have to cut the long guidewire.

When it came time to cut the guidewire, the video was not transmitting to the ground due to blockage of the Ku-band antenna (see Chapter 13). While the Mission Control team held its collective breath, Parazynski cut the wire and Wheelock controlled the speed as it zipped into the reel at the bottom of the array. When Wheelock reported the array had successfully retracted, the team in the control center literally cheered.



**Figure 20.** Parazynski riding on the OBSS—“the boom”—to perform the array repair. The boom is grasped by the ISS robotic arm. The other end of the arm is grasping part of the Mobile Remote Servicer Base System on the truss. This photo was taken by the crew inside the ISS, whose main task at this time was operating the arm and monitoring the EVA crew. Wheelock is not shown in this photo because he is translating along the truss structure using his hands.

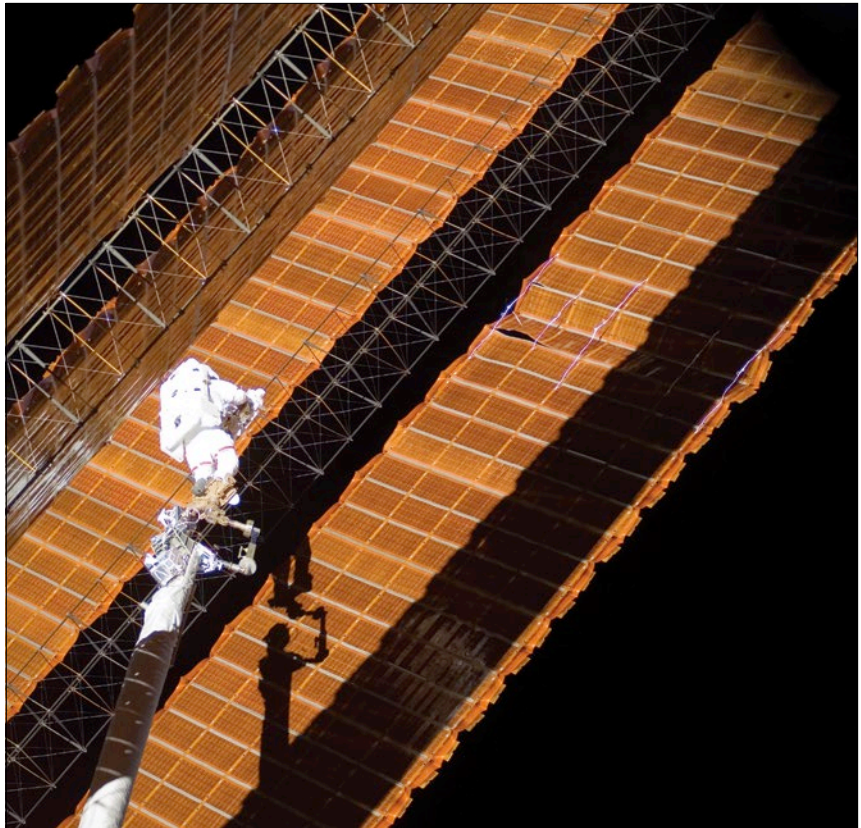


**Figure 21.** Parazynski is being hoisted to the repair site, approximately halfway up the array. Wheelock is at the base of the array, looking up to give clearance calls so the loose array would not come in contact with his crewmate.

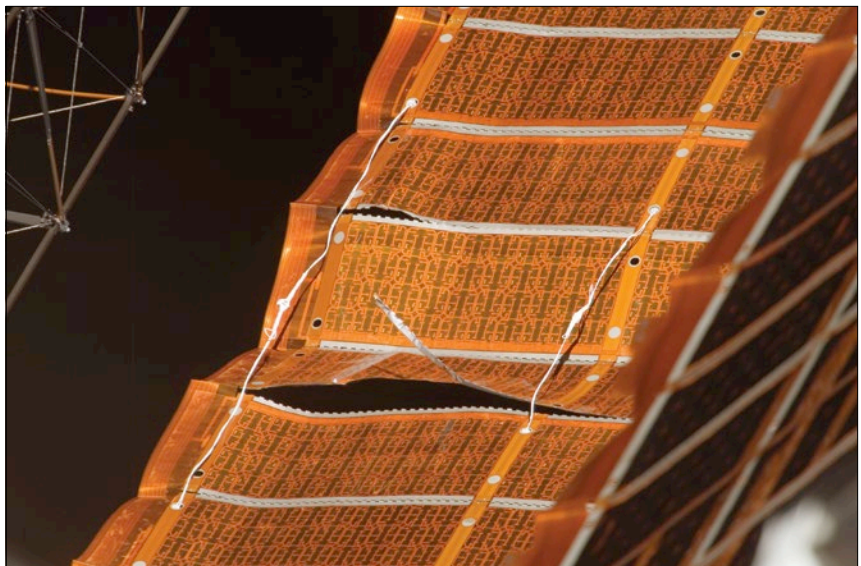


**Figure 22.** Parazynski, partway through the repair. Three of the five required cufflinks are installed.

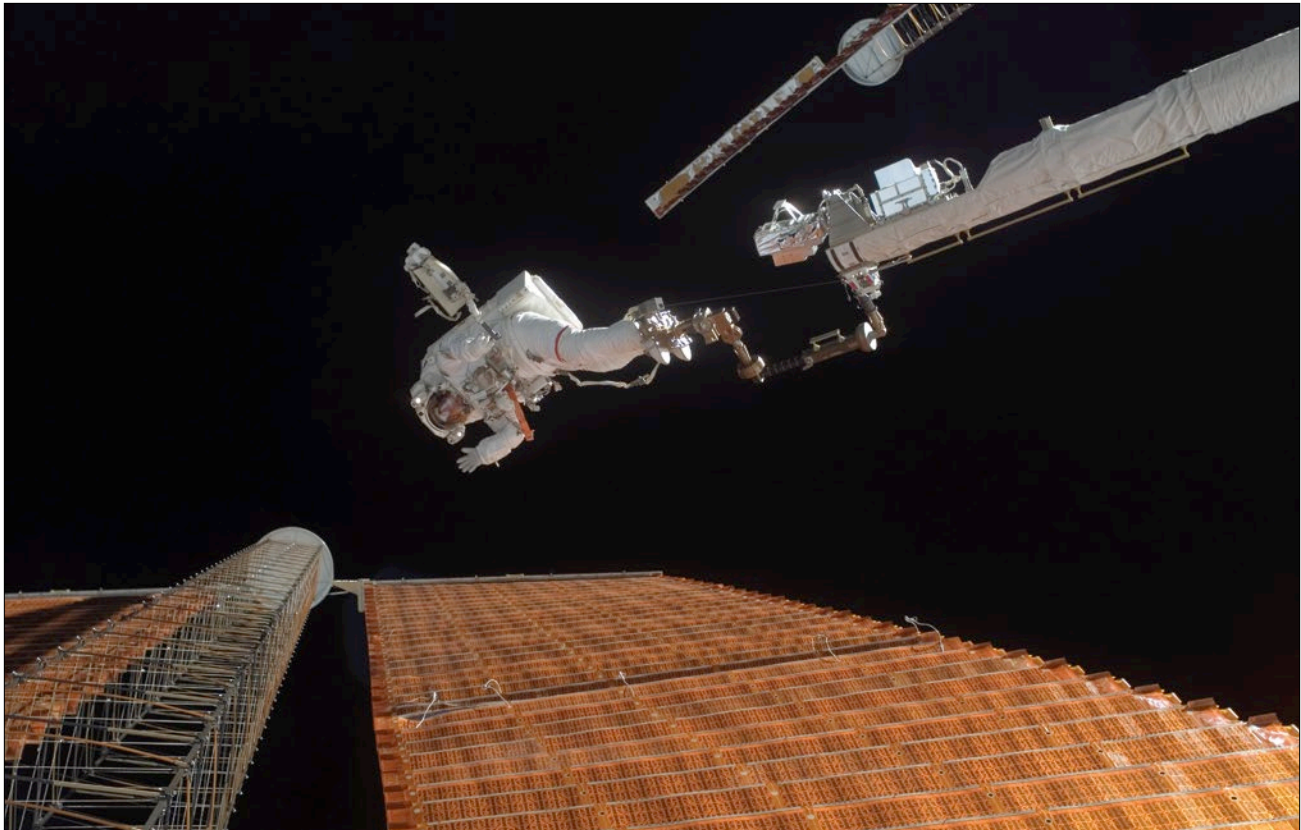
The cufflinks installed pretty easily, thanks to a good ground design and build-up by the crew. But the installation into the upper holes required more reach than the robotic arm possessed. Some truly tense Mission Control moments occurred when the arm was stretched as far as it could go, yet Parazynski needed to go a little bit higher even though he is a tall individual. This situation felt like a simulation in Mission Control when instructors throw a really hard malfunction in to see if the flight controllers sweat. In the end, the ground agreed to have Parazynski pull the upper part of the array down some using his tools, thereby allowing him to install the upper end of the cufflinks. Figures 21-25 show the view on the ISS during the spacewalk, whereas Figure 26 shows the activities going on inside Mission Control during the EVA.



**Figure 23.** Parazynski is watching the array unfurl and photographing the final state of the cufflinks (top right) after performing the repair. The control center watched the repair sites during the array deploy to determine whether the repair was working. The control center view was from a video camera mounted on Parazynski's helmet.



**Figure 24.** The repair was successful in bridging the gaps in the array, with the white cufflink cords holding together the pieces so the hinge areas did not zipper open any further.



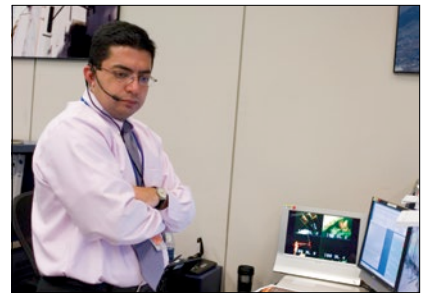
**Figure 25.** This photo of Parazynski just after cufflink installation was taken by Wheelock, who was at the base of the array. The cufflink repairs are the white cords partway up the array.



**A**



**B**

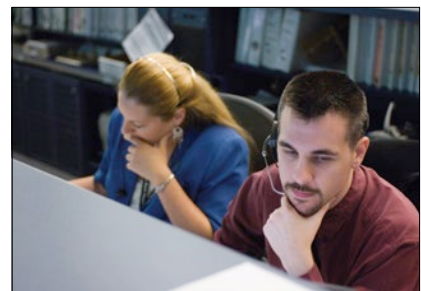


**C**

**Figure 26.** Photos of Mission Control during the EVA. (A) Flight Director Derek Hassman leaning on console, with Capcom Steve Swanson. (B) Some Team 4 key players: (left to right) Flight Director Annette Hasbrook, astronaut Joe Tanner, EVA specialist John Ray, and Mission Evaluation Room manager Becky Tures. (C) Robotics officer Sarmad Aziz. (D) (left to right) Flight Surgeons Dr. Sean Roden and Dr. Robert Haddon, Biomedical Engineer Chris Goetter, and EVA officer Dina Contella (2 years later, Contella was selected as a flight director). (E) (left to right) Electrical Power experts at the PHALCON position, Tamara Cougar and Scott Stover (2 years later, Stover was selected as a flight director).



**D**



**E**

The team predicted the EVA would be fairly long. The EVA team in the control center had to balance reserving the consumables of the spacesuit with the criticality of having Parazynski (and his helmet camera) watch deploy of the array. After a lot of discussion about the suit consumables while Parazynski cut the guidewire and installed the cufflinks, the team decided enough spacesuit consumables remained to have the EVA crew watch as the array successfully deployed. The spacewalk ended up with a duration of 7 hours 19 minutes, which was not too exceptional, due to quick work by the crew to clean everything at the end of the EVA. The crew even managed to retrieve the two suspect foot restraints so that they could be inspected inside for sharp edges.

The tools worked great, and Parazynski used the hockey stick like his “best friend” to keep the array at a safe distance. During the EVA, a pair of needle nose pliers was lost overboard (i.e., floated away from the ISS) due to the way a tether line was routed. However, the Trajectory Operations Officer quickly analyzed the trajectory of the tool, and determined the pliers did not pose a risk for coming around and hitting the ISS on a later orbit. Weeks later, the team discovered during video review that another tool had been lost—the Russian dinocutters. This loss was not noticed during the mission, which is unusual. The crew

and ground team missed double-checking the presence of this tool during the post-EVA tool review, probably due to the last-minute nature of the activity and the need to focus on the end of the mission and shuttle undocking. Also, a camera did not work on that EVA. The camera had the same signature as the camera failure on EVA 2, which was later theorized to be a blanket holding down the shutter button and draining the battery. The boom sensors had been unpowered around 9 hours, but a checkout later confirmed they were working.

The array deployed to its highest tension mode (i.e., the regular operational mode for the array) and rotated nominally. It was generating 217 amps, which is 3 amps less than what would be expected normally. This was probably due to damage of some of the cells, but only a small fraction of the power generation capability had been lost. As of this writing, the array repair with its cufflinks has held together well for several years—a testament to those who worked so hard to put it in working order.

With this success, the shuttle could undock. The next EVAs were already being put on the plan for the ISS crew, including the deferred stage EVA that Whitson and Malenchenko were to perform after the shuttle departed. The European Columbus module ultimately flew up during the STS-122/ISS-1E mission in February 2008.

## Looking Back

Adaptation was key. Before flight, the team meticulously pre-planned for three spacewalks (one of which was altered in flight to examine a failing truss rotary joint), then added a fourth and fifth spacewalk pre-mission, neither of which was actually executed during that mission. That mission was altered by adding a new spacewalk in flight due to a major failure in a rotary joint. That spacewalk was not executed during the mission either. Ultimately, through an enormous effort by a large technical international community, flight controllers and engineers executed an entirely new spacewalk to repair a damaged solar array.

Preparations for the unexecuted EVAs were not wasted, however. That hard work created a solid team that was able to change the spacewalks, in the moment, and execute them as if they had been planned and tested on the ground, preflight. Even though some additional risk was accepted for one of the most critical spacewalks done to date, the flight directors and mission management team ensured that the team was properly ready and no unnecessary risks were taken by the team or the crew.

In hindsight, a combination of factors came together in a perfect way to enable this success. For example, the Space Shuttle boom was available, enabling reach to a distant place that would not have been possible before the Columbia accident decisions

that led to flying a boom for shuttle repairs. Additionally, a history of smaller but also critical past solar array deploy issues seasoned the electrical power and EVA teams, readying them in advance for this incredibly daunting challenge. A skilled robotic and EVA crew, strong leadership on board the shuttle and ISS as well as on the ground, and experienced flight controllers in Mission Control were all contributing factors in this success. These factors were not “dumb luck.” NASA and Flight Operations spend a lot of time preparing for the unforeseeable. Even in the best of conditions, factors do not always come together, which is why this team was relieved and exuberant with the outcome.

It had been an incredible spacewalk and mission. Cheering had erupted in Mission Control, and the celebration was well earned. However, the next spacewalk by the ISS crew was only a few days away, which meant the team would soon get back to business.



## Chapter 19 **Systems:**

Environmental  
Control and  
Life Support System—  
Supporting the  
Human Element  
of the International  
Space Station



Astronauts drink water that has been recycled from urine and sweat on the International Space Station.

**If Command & Data Handling is the brains of the International Space Station (ISS), the Environmental systems are the heart and lungs of the vehicle.**

Adding humans to a spacecraft brings a significant overhead in terms of life support. An atmosphere must be provided for humans to survive in the harsh frontier that is space; living in a space suit would be neither practical nor supportable for any significant amount of time.

A fundamental aspect of the ISS is to provide a shirtsleeve environment in which astronauts can conduct research. To this end, the Environmental Control and Life Support System (ECLSS) provides a breathable atmosphere at a normal atmospheric pressure. This means the system provides oxygen ( $O_2$ ) and nitrogen ( $N_2$ ) at the same ratio as on Earth while removing contaminants such as carbon dioxide ( $CO_2$ ) and other impurities in the gas. As on Earth, water is the most critical consumable after  $O_2$ . Water is required for survival, rehydrating food, bathing, and waste removal.

Early space stations such as Skylab required the astronauts to carry with them all the gas and water, which were consumed. On the United States On-orbit Segment (USOS), the goal is to recycle and generate as much of these commodities in as closed loop as possible. For example, drinking water turns into perspiration and urine. In turn, sweat is collected out of the atmosphere by a dehumidifier while urine is separated from other waste and stored. The sweat and urine are then carefully processed back into drinking water. These types of technologies and processes will need to be well established and reliable if humans are to travel to Mars.

The ISS life support system is designed to handle seven crew members routinely and can support a surge of up to 11 for a brief period of time. Pressure on the ISS is normally maintained between 724 to 770 mm Hg (14.0 to 4.9 psi), which is equivalent to what is experienced around sea level on Earth. For crew comfort, temperatures are maintained at 22°C to 26°C (72°F to 79°F). Humidity can be controlled

to whatever level is desired, but it is generally kept low (~45%) for crew comfort and to minimize water condensing on critical surfaces of the space station.

The Environmental and Thermal Operating Systems (ETHOS) flight controller is responsible for monitoring these systems continuously; ETHOS carefully tracks  $O_2$ ,  $CO_2$ , and every drop of water. Many of these same systems are found on the Russian Segment (RS); therefore, careful coordination is required between the two teams. Since most emergencies (i.e., fire, loss of atmosphere, chemical spill) affect the atmosphere, ETHOS has one of the most critical jobs on the flight control team: emergency response. If any of these problems occur, ETHOS guides the flight control team and astronauts through the procedures, thereby ensuring crew safety. Of all the areas in which the flight control team trains, emergencies get the most attention. Fortunately, to date, no serious problems have occurred, mainly due to the vigilance of the ETHOS team.



## Atmosphere Control and Supply/Atmosphere Revitalization

On the ISS, O<sub>2</sub> and N<sub>2</sub> levels are maintained to values typical of those on the surface of Earth at sea level. Dry air consists of about 78% N<sub>2</sub> and 20% O<sub>2</sub>, by volume. Human respiration takes O<sub>2</sub> into the lungs, which is absorbed in the body, and releases CO<sub>2</sub>; gaseous N<sub>2</sub>, being inert, is not consumed in the process. Hypoxia, and eventually death, will occur if the O<sub>2</sub> levels drop too low. In certain cases, humans can survive for limited intervals with lower levels of O<sub>2</sub>. The O<sub>2</sub> level may be dropped to the equivalent altitude of 3048 m (10,000 ft) for up to a day in a contingency. As the crew members breathe, O<sub>2</sub> levels need to be replenished over time. In a perfect system, N<sub>2</sub> would never need to be resupplied; however, a small amount of leakage occurs on the ISS, as well as lost gas, when vestibules are depressed to allow vehicles to depart, thus necessitating replenishing. It is important to keep the level of O<sub>2</sub> high enough for the crew to adequately breathe, but not so high as to create a flammability risk, as O<sub>2</sub> is a highly flammable gas. If the concentration of O<sub>2</sub> is kept lower than approximately 24%, the risk of a spark causing a combustion event is fairly low at the atmospheric pressure on the ISS. Short-term exceptions are allowed during preparation for spacewalks (see Chapter 17).

Two ways to get these critical gases on the ISS include delivering the gasses in a tank or generating them in situ. Various vehicles—Russian

Progress, European Space Agency's Automated Transfer Vehicle, Space Shuttle, Japan Aerospace Exploration Agency's H-II Transfer Vehicle (HTV), Dragon, and Cygnus—transport O<sub>2</sub>, N<sub>2</sub>, or air (a mixture of N<sub>2</sub> and O<sub>2</sub>) to the ISS. Progress and the Automated Transfer Vehicle have large storage tanks. A valve is opened for a predetermined amount of time to bleed some O<sub>2</sub>, N<sub>2</sub>, or air into the main cabin whenever the atmosphere on the ISS requires more gas.

Three O<sub>2</sub> tanks are situated outside of the airlock. One tank is used to resupply the atmosphere, whereas the second and third are primarily used for the Extravehicular Activity (EVA) Mobility Unit (EMU) (see Chapter 17) and are intended to be used only for the general atmosphere



**Figure 1.** Astronaut Dan Burbank works on the OGA during Expedition 30.

in an emergency. A fourth O<sub>2</sub> tank is stowed outside on the ISS truss. This tank can be accessed via an EVA, if the tank is required. The Dragon, Cygnus, and HTV vehicles can also bring up O<sub>2</sub> and N<sub>2</sub> tanks, which are called the Nitrogen and Oxygen Resupply Systems tanks. The tanks can either be vented directly to the cabin, as above, or be used to resupply the external O<sub>2</sub> and N<sub>2</sub> tanks outside of the airlock for future use.

Transporting O<sub>2</sub> to the ISS is costly; therefore, it is better to generate O<sub>2</sub> in situ where possible. Both the USOS and the RS have generators that can produce O<sub>2</sub> from water using electrolysis, which is the process of splitting water molecules into hydrogen (H<sub>2</sub>) and O<sub>2</sub> using electricity. Having two independent systems provides redundancy if one suffers a problem. The Oxygen Generation Assembly (OGA) (Figure 1) performs this task on the USOS.

Finally, O<sub>2</sub> can be supplied by the Solid Oxygen Generator where solid “candles” are burned, thereby producing O<sub>2</sub> as a by-product. Candles have been used in places such as submarines for years. These candles are used in an extreme contingency case due to flammability risk (see *Dragonfly*, 1998). The ETHOS flight controllers monitor the O<sub>2</sub> levels closely and work with their Russian counterparts to ensure the right levels are always available.

The Pressure Control Assembly (PCA) monitors the total pressure of the cabin air. Similar sensors are present in the Columbus Module and Japanese Experiment Module (JEM). Not only does the PCA measure the

total pressure and trigger an alarm if the pressure gets too high or low, the PCA can automatically introduce O<sub>2</sub> and N<sub>2</sub> from the external tanks on the airlock. As discussed in Chapter 3, pressure above a critical limit can rupture the shell of the ISS, thereby introducing a catastrophic leak. Too low of a pressure can cause the astronauts to lose consciousness and die. If the pressure gets too high (>777 mm Hg or 15.03 psi), the PCA uses its Vent and Release Assembly (VRA) to release gas outside of the spacecraft. In case of a problem with the VRA, the Positive Pressure Release Assembly (PPRA) can also vent the atmosphere. The trigger point of the PPRAs (>778 mm Hg or 15.05 psi) is set higher than the PCA and would only vent in a significant emergency. The PPRAs are essentially large vents on the ISS, and they can release about 68 kg/hr (~150 lbs/hr) of gas. These might also be used in an emergency response (see below). However, the flight control team monitors the atmosphere closely since any gas that is vented is a waste of a critical commodity. Similar devices are present in the Columbus Module and JEM.

Careful measurement of the O<sub>2</sub> and N<sub>2</sub> quantities in the atmosphere is required for the PCA or the ETHOS flight controller to know whether either levels need to be adjusted. Composition of the atmosphere is measured by the Major Constituent Analyzer (MCA). The MCA consists of a mass spectrometer that can measure O<sub>2</sub>, N<sub>2</sub>, CO<sub>2</sub>, H<sub>2</sub>, water, and methane in the atmosphere. The USOS is lined with tubes that make up the Sample Delivery System (SDS). The MCA draws in a small sample of atmosphere from each

module and measure the constituents. An alarm will be annunciated if any component is outside of the expected limits. If this occurs, the MCA will repeatedly sample the atmosphere in that module so the crew and ground can monitor the situation. Otherwise, the system will move on to the next module and keep cycling.

Several handheld devices can also be used to measure atmospheric contaminants. These devices consist of the Carbon Dioxide Monitor (CDM), the Compound Specific Analyzer-Combustion Products (CSA-CP), and the Chip Measurement System (CMS). See Figure 2. All three devices work essentially the same way by pulling in cabin air and measuring the constituents. The CDM is mainly used in situations when a localized area needs to be monitored; e.g., if a crew is working in an area where ventilation is poor. The CSA-CP is the main tool to determine the constituents of smoke or whether there is a fire inside of a rack. It measures the levels of carbon monoxide, hydrochloric acid, and hydrochloric cyanide—typical and dangerous by-products of a fire for the type of materials used on the ISS. The CSA-CP has a long tube attachment that can be inserted into holes in the racks to measure the presence of smoke that may not be visible. Finally, the CMS on the USOS measures ammonia, whereas the Russian CMS detects formaldehyde, benzene, styrene, ozone, phosgene, carbon monoxide, ammonia, and nitrous fumes.

After O<sub>2</sub> and N<sub>2</sub>, CO<sub>2</sub> is the next-biggest atmospheric concern. Even low levels of CO<sub>2</sub> can impair the mental acuity of an astronaut,

especially if the exposure occurs over a long period of time. The amount of a gas is measured in terms of partial pressure, which is the amount of the pressure that a specific gas contributes to the total pressure. The average partial pressure of CO<sub>2</sub> at the surface of the Earth is less than 1 mm Hg, or about one-tenth of a percent of the total pressure. On the ISS, the level is maintained to be less than 4 mm Hg and is typically around 3.5 mm Hg. Some astronauts reported headaches when the levels went above this amount. Exposure to values above 20 mm Hg can lead to headaches, increased respiratory rate, reduced performance decrement, and possible depression of the central nervous system. Recent research may also indicate that a person's sensitivity may change in weightlessness. The primary way of removing CO<sub>2</sub> on the USOS is via the Carbon Dioxide Removal Assembly (CDRA). See also Figure 3. A similar device is located on the RS. In the event of failure, the crew can load Lithium Hydroxide (LiOH) canisters into a fan assembly to filter the CO<sub>2</sub> as a backup. The LiOH canisters absorb CO<sub>2</sub> in a chemical reaction. However, this is a contingency plan only, as it uses a non-regenerative consumable. Even maintaining low levels is not adequate to keep crew members healthy. Gravity causes warm gases to rise and cooler ones to sink. This helps mix atmospheric gases, dispersing those such as CO<sub>2</sub>. In the absence of gravity, fans are needed to perform this function on the space station or as an astronaut breathes in one place, since a local pocket of toxic gas can build up. The ventilation on the ISS is designed to keep levels of CO<sub>2</sub>



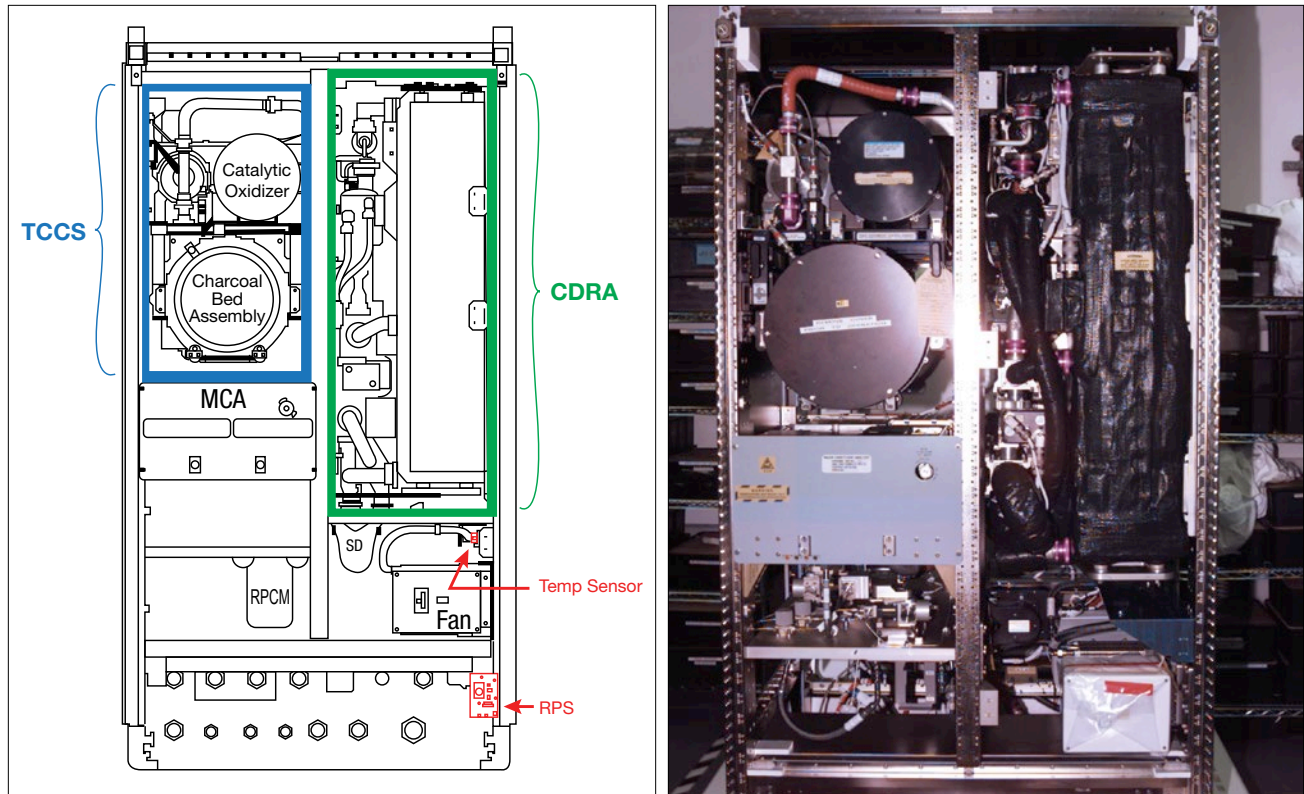
**Figure 2.** GSA-CP (left) attached to the wall of Node 1 and CMS (right). For the CSA-CP, the metal detector (gray), which is about 15 cm (6 in.) in length, is placed in the black holder that pumps air in through a tube, which is currently connected to a long rod that can be inserted into racks.

uniform. This is even more critical in the small phone-booth-sized crew quarters where crew members sleep. Therefore, redundant fans and an alarm system are present in those units to ensure the health of the sleeping astronaut.

A CDRA is located in both the Laboratory module and Node 3 module, though only one at a time is usually operating. Note that it is not practical to operate both CDRA's simultaneously to lower the CO<sub>2</sub> level further. The CDRA consumes a significant amount of power (around 1 kW) and generates a significant amount of heat. Operating a second

unit can lower the level further, but at the expense of wearing out sooner. The CDRA is actually two sets of filter bed systems that alternately operate one set to purify the air while the other is being cleaned. Air is first pulled into the CDRA from the Common Cabin Air Assembly (CCAA) over a bed of desiccant to remove humidity. The desiccant bed uses silica gel and zeolite, and is similar to the small packets found in food products or shoes. Drying the air allows the next filter bed, an absorbent material, to remove the CO<sub>2</sub> more efficiently. The air is then pushed through a second

desiccant bed that was previously used to remove water vapor and therefore contains excess water. This actually rehydrates the air a little before it reenters the cabin. After a while, the absorbing bed becomes saturated and can no longer remove the CO<sub>2</sub>. At this point, it is taken out of the air flow and heated to a high temperature, which causes the trapped CO<sub>2</sub> to be released. Released CO<sub>2</sub> is either vented to vacuum or piped over to the Sabatier (see below). The second set of desiccant and absorbent beds remove CO<sub>2</sub> while this bake-out is occurring, and the cycle keeps repeating.



**Figure 3.** CDRA and the TCCS in the Atmosphere Revitalization Rack—schematic (left) and actual rack before launch (right). Also seen in the drawing are the MCA, the Remote Power Control Module (which powers the rack), and a fan that helps blow smoky air over the smoke detector to determine the presence of fires as well as to provide cooling. The Rack Power Switch allows the crew to power off the entire rack quickly in the event of a fire.

Another tool in keeping the air clean is the Trace Contaminant Control System (TCCS). The TCCS (Figure 3) can remove most of the more than 200 possible contaminants on the ISS, including hydrocarbons, ketones, silicones, aldehydes, sulfides, and inorganics. The TCCS works mainly by pulling air through various filter beds that consist of activated charcoal, a catalytic oxidizer, or LiOH. The TCCS can even absorb small amounts of ammonia, but it would be inadequate in the event of an Interface Heat Exchanger (IFHX) breach. Once the filters have absorbed as much contaminants as they can

hold, they are disposed of and new ones are installed.

After providing the crew with the proper atmosphere needed to live and work, the next priority of the ECLSS is to offer support for scientific payloads. Nitrogen lines are plumbed throughout the Laboratory module and can be fed into payload racks. Nitrogen is usually used to purge some other gas from an experimental rack, but nitrogen may have other uses determined by the researcher. Also, two types of vacuum lines are available for the payloads. One type is the Vacuum Resource System (VRS), which is an open line to

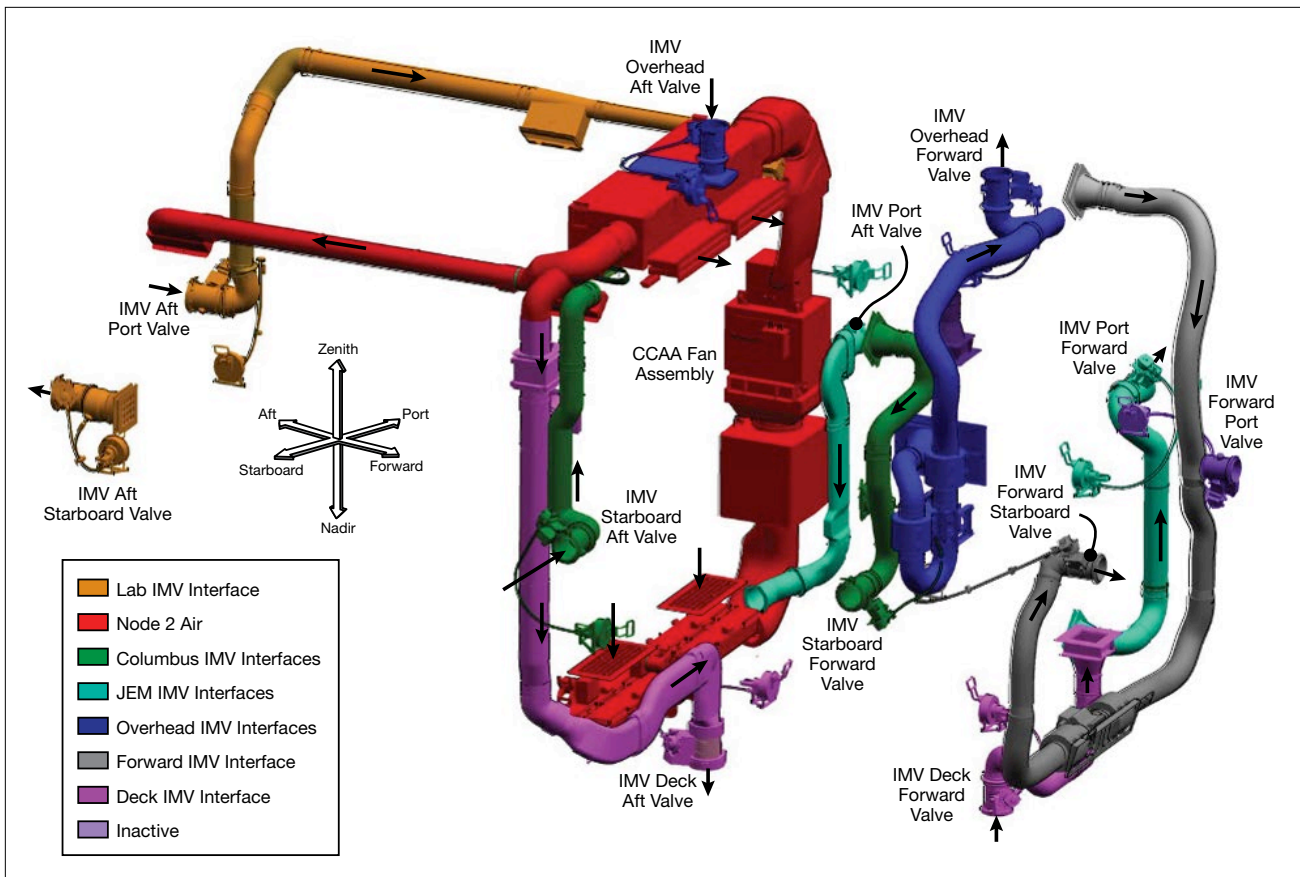
space. Although the space around the ISS is not a perfect vacuum, owing to small amounts of gas (mostly  $O_2$ ), the pressure is about 10 to 100 billion times lower than at the surface of the Earth and is as good or better than the best vacuum chambers on Earth. If an experiment requires vacuum to operate, it would be connected to this system to allow a constant vacuum, as needed. This will occur after the experiment itself has undergone careful analysis to ensure it cannot easily leak. If an experiment uses chemicals or gasses that need to be removed after a trial run (e.g., during combustion research), these

can be removed by hooking up to the Vacuum Exhaust System (VES)—a similar line running to space. One key difference in the VES is that the opening to space is directed away from any important structure; therefore, residue doesn't build up on critical surfaces. The VES also has a diffuser attached so that the escaping gas imparts no particular thrust.

A final component of the atmospheric control system is the Intermodular Ventilation (IMV) shown in Figure 4 for Node 2. The IMV system is basically a bunch of air ducts plumbed around the USOS

to exchange air between modules, thus allowing for good mixing. It is critical to mix the O<sub>2</sub> generated by the OGA; this will allow the crew to breathe and will prevent pockets of toxic CO<sub>2</sub> from forming, as noted above. Fans push the air between modules through the ducts, whereas intramodular air circulation occurs within the individual modules via the cabin fan or CCAAs. The IMV system can recirculate all the air inside the ISS in about 2-3 hours. In the case of a fire or chemical spill, IMV fans are shut off and IMV valves actually close to prevent further mixing of anything bad throughout

the vehicle. The hatch can be closed to completely isolate a module in the event of a serious emergency. The pressure on both sides of the hatch needs to be the same when opened; otherwise, the crew will be unable to move it. Even a pressure differential of only 0.3% of that at sea level—a differential too small for a human to detect—can make it impossible to open a hatch because the hatch area is so large. Therefore, Manual Pressure Equalization Valves (MPEVs) are located on the hatches to allow the air to balance out before opening the hatch. An example of the IMV system is shown in Figure 4.



**Figure 4.** An example of the plumbing for the IMV. In this case, for the Node 2. The forward port valve is at the front of the module, whereas the after port valve is at the far end, approximately 7.2 m (~24 ft) away. The CCAA is approximately in the middle of the module. Arrows show the flow of air into and out of the CCAA.

## Temperature and Humidity Control

Not only does the crew need to be comfortable, some equipment requires the air in the ISS to remove excess heat (i.e., air cooled). CCAAs in the Laboratory, Node 2, Node 3, and airlock, and similar air conditioners in the International Partner modules, circulate, cool, and dehumidify the air. The CCAAs are connected directly to the IMV ducting (Figure 4). The ducting passes air between all the modules to ensure uniform mixing.

Air is pulled into ducts that feed the CCAAs and passes through High Efficiency Particulate Air (HEPA) filters, in the same way as household systems do on Earth. Although the crew and spacecraft are kept as clean as possible on the ground, a fair amount of particulates are present on the ISS. These filters have to be vacuumed fairly regularly since, in microgravity, objects collect on the inlet of vents and not on the floor. This process also acts as a handy way to find missing items—e.g., lost screws, misplaced washers, small tools, or even a pack of gum or a fork.

A fan pulls the air in through the HEPA filter and past the Condensing Heat Exchanger (HX). The air passes over metal layers that are cooled by water from the Low Temperature Loop (see Chapter 11). When air hits the cool plates, the water condenses on a plate where it is drawn into small holes and separated from the air. The cooler and dehumidified air is then vented directly into the cabin. If the crew members want the air temperature to be warmer, they (or the ETHOS flight controllers)

## Why do we process the urine on the ISS instead of taking up fresh water?

The basic answer is cost. Six crew members produce about 9 kg (~20 lbs) of urine a day. About 70% of that, or 7.7 kg (17 lbs), is processed into water. In 2015, it cost about \$25,000 to launch 0.5 kg (1 lb) of water to the ISS. This translates into approximately \$425,000 of cost savings per day, or more than \$155,125,000 a year in water that doesn't have to be launched.

can command the system to slightly close doors within the ducting of the fan, which reduces the amount of air passing over the cooler plates. For a cooler cabin, the doors are opened more fully, thus more air is passed over the plates.

Since air is used to push the water into the collection holes, a mixture of water (~90%) and air (~10%) comes out the other side. The water enters a small centrifuge. As the centrifuge spins, the heavier water is pulled out from the air. The water is then routed to the condensate tubing where it can go either to a big condensate tank for storage or into the Water Processor Assembly (WPA).

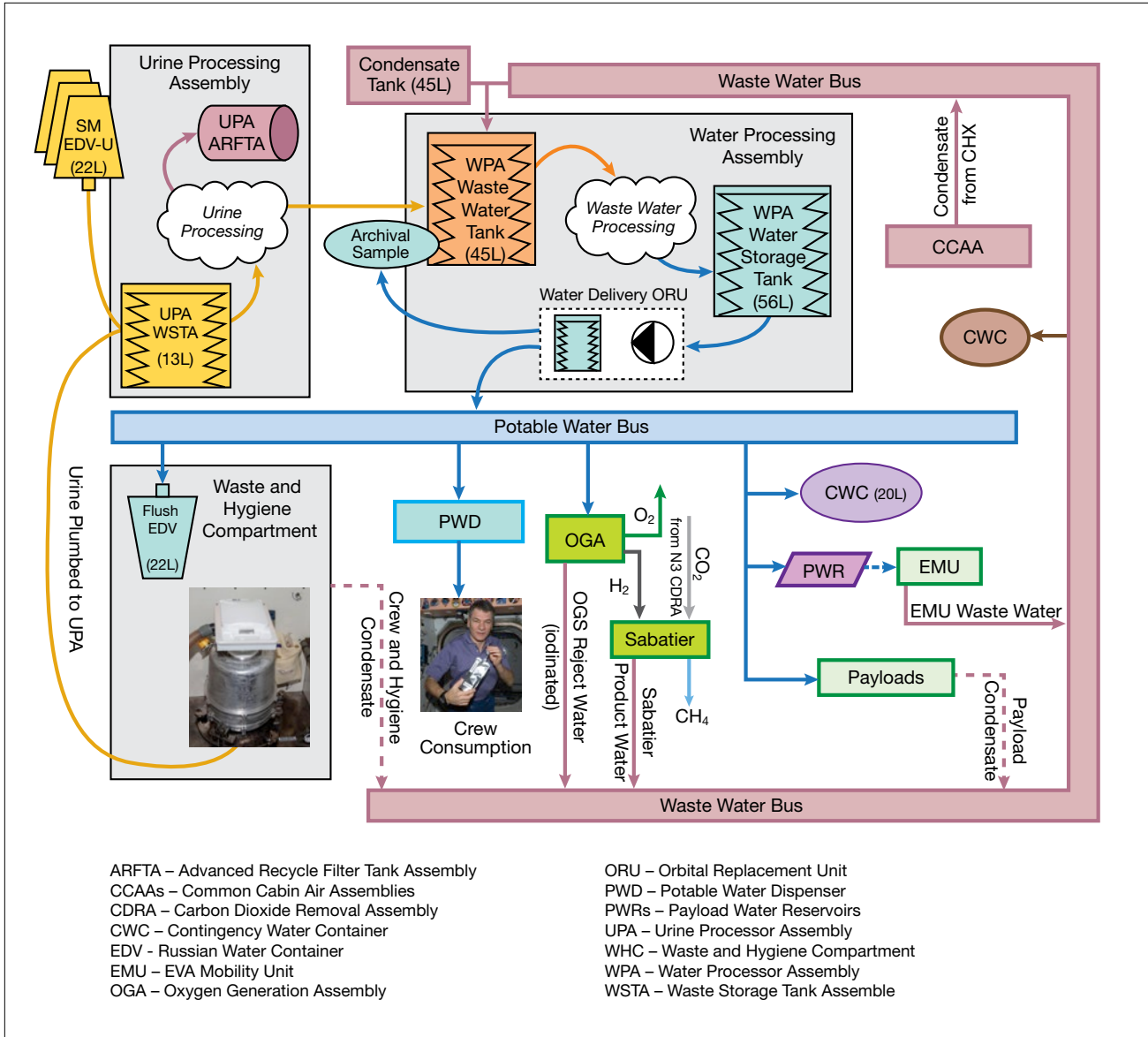
## Water Recovery and Management

As on Earth, water is a precious commodity in space and, therefore, is managed carefully by the flight control team. Water is transported to the ISS by one of the various cargo vehicles. The six types of water on the ISS are listed in Table 1. One of the key functions of ETHOS is to track the various quantities of water to ensure an adequate amount of each type. This section will discuss the life cycle of water on the ISS, which is depicted in Figure 5.

As mentioned in the previous section, condensate water from the USOS

**Table 1.** Types of Water in use on the ISS

Type	Use
Potable Water	Drinking water via the Russian systems for the crew containing a silver-biocide to retard microbial growth and minerals for taste.
Technical Water	Contains silver-biocide to retard microbial growth and is used for crew hygiene, Russian toilet flush water, and in the Russian O <sub>2</sub> generator to produce O <sub>2</sub> .
Condensate	Water recovered from the atmosphere, which is processed back into potable water.
Waste	Urine or water that was used in the EMU (see Chapter 17).
Special Fluid	Water used for the internal cooling system or other uses, and which may contain chemicals to retard biological growth or chemical reactions and cannot be used for drinking.
Iodinated	Similar to technical water but with iodine biocide; this type of water is used in the USOS water systems for toilet flush, the OGA, and, when stripped of iodine, the crew drinks it.

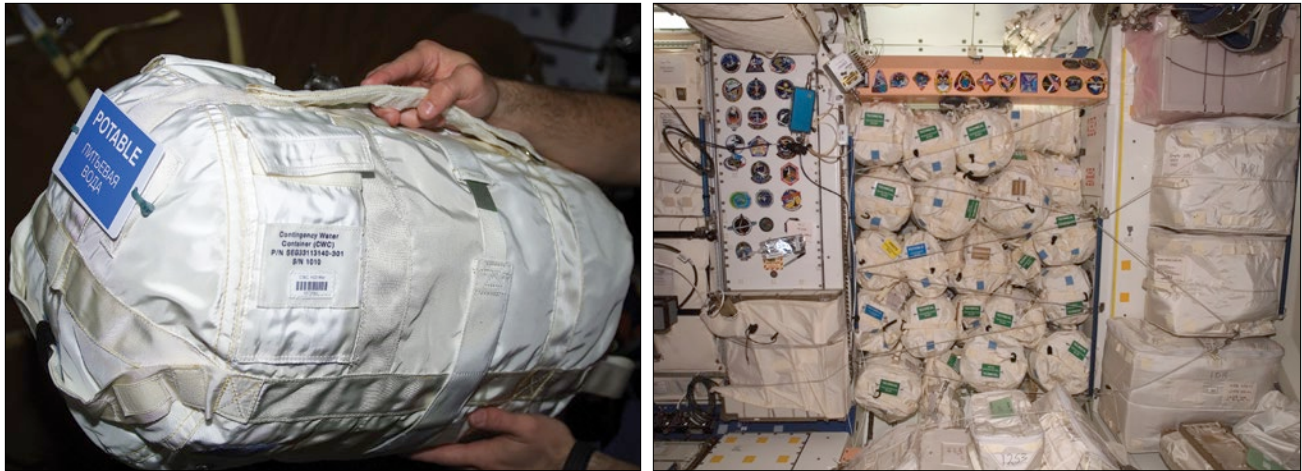


**Figure 5.** A schematic showing the overview of the water processing system. Wastewater from the Waste and Hygiene Compartment (WHC) is transferred to the Urine Processor Assembly and the WPA. From the WPA, clean water is placed on the potable bus where it can be transferred to the O<sub>2</sub> generator, the crew's drinking station (Potable Water Dispenser), or the Sabatier, or used for EVA Mobility Units or for flush water in the WHC.

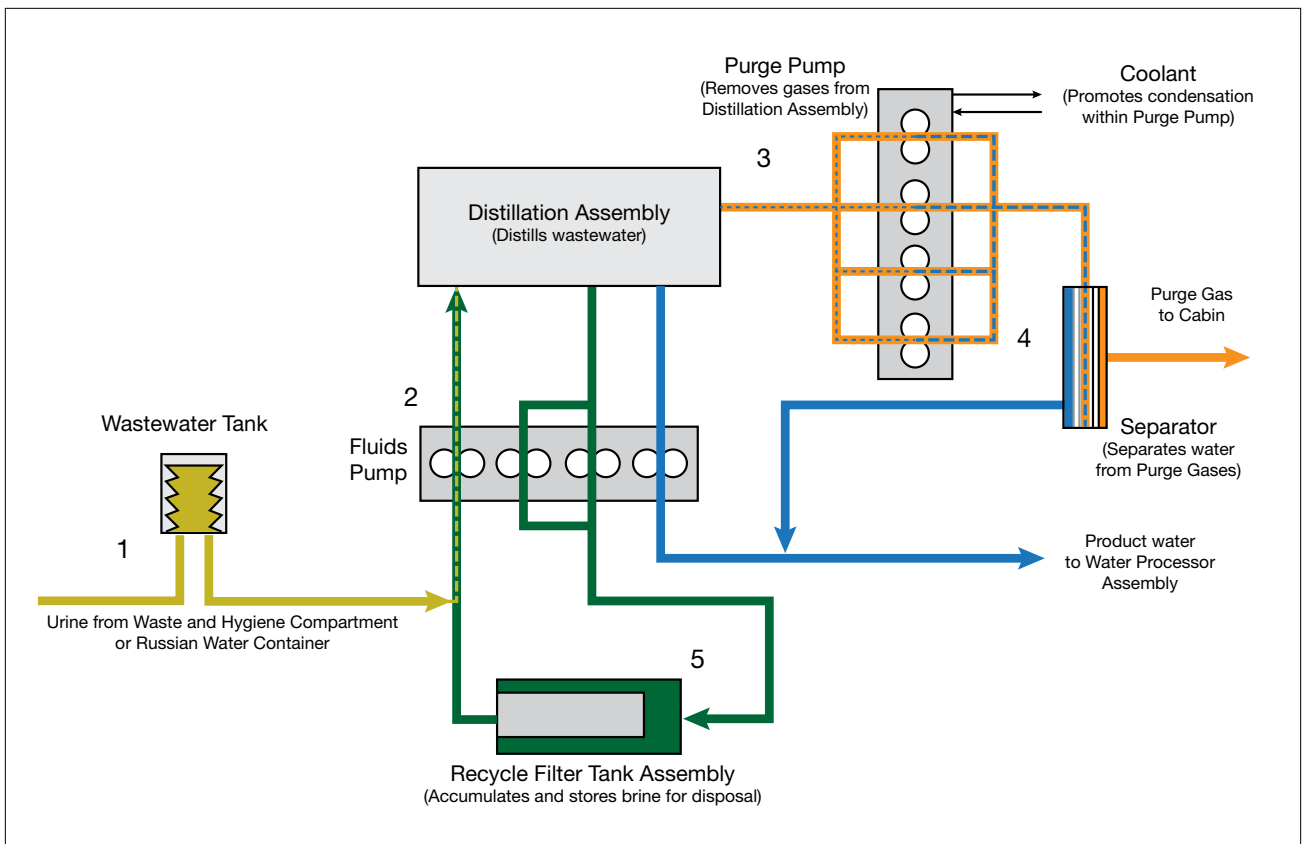
is collected in the WPA wastewater tank. If the WPA wastewater tank is not available due to a failure, the crew can configure some jumpers and send the water to be stored in a condensate tank. If the tank

gets too full, it is possible for the ETHOS flight controller to open a series of valves and vent some of the water overboard; however, this is a last resort, as it results in loss of this precious liquid. The

crew would offload the water into a Contingency Water Container (CWC) (Figure 6) prior to being full. The CWC is essentially a flexible bladder surrounded by fireproof fabric material that can hold about



**Figure 6.** A full CWC (left) and the “water wall” in Node 1 (right). Note that a CWC is about 61 cm (24 in.) long with a diameter of 24 cm (18 in.) and can hold about 43 liters (12 gal) of water.



**Figure 7.** The Urine Processor Assembly schematic. Water comes from the waste storage tank to the Advanced Recycle Filter Tank Assembly and through a distillation process before gases are removed in the purge pump.



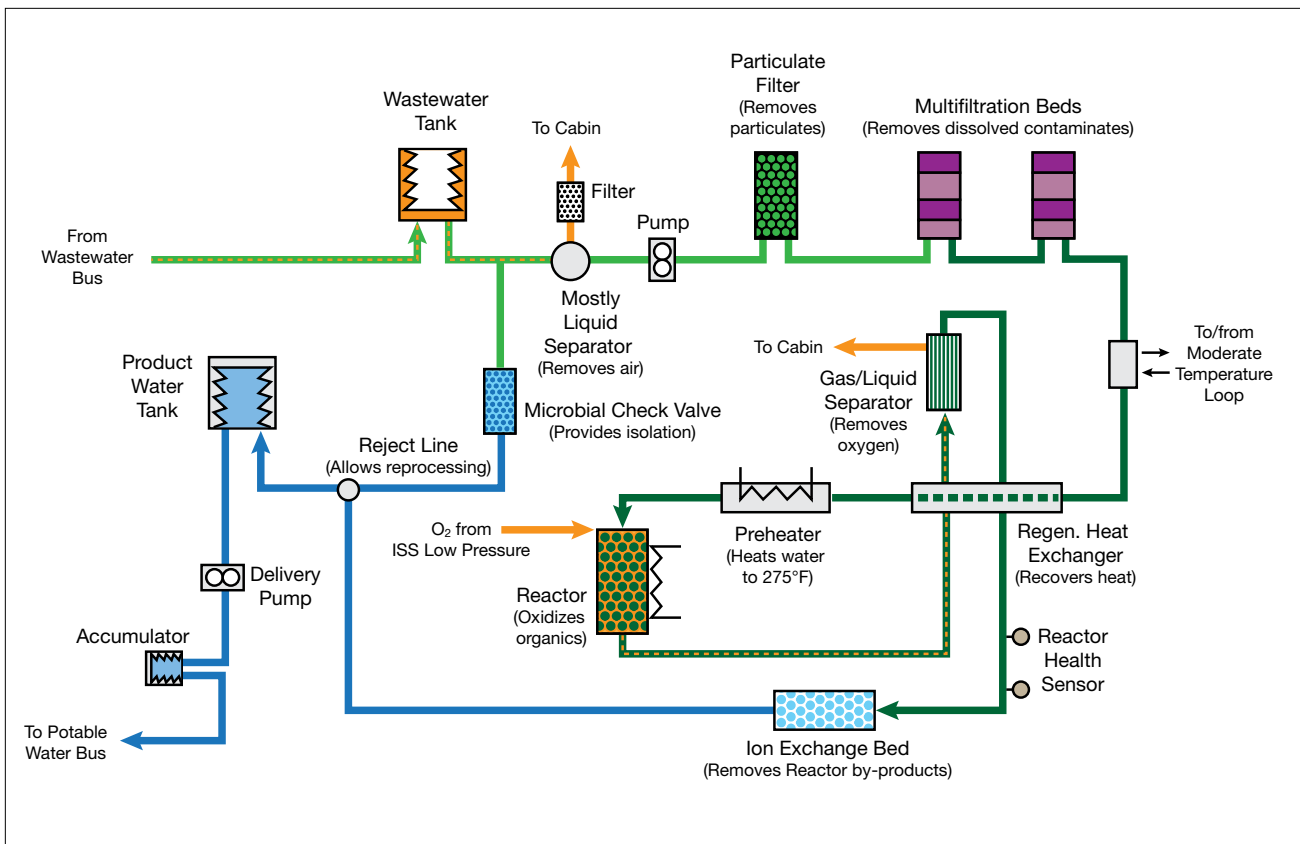
43 kg (~95 lbs) of water. Cargo vehicles such as the HTV can also deliver water using CWCs, which are then stored until they are processed by the WPA. Similar containers are available on the Russian side.

Additional wastewater comes from the Urine Processor Assembly (UPA) (Figure 7), which receives input from the Waste and Hygiene Compartment (WHC). A crew of six generates about 9 kg (20 lbs) of urine a day. Using flush water, the WHC sends the urine to the UPA (solids are retained in a tank to be disposed of later). Urine consists mostly

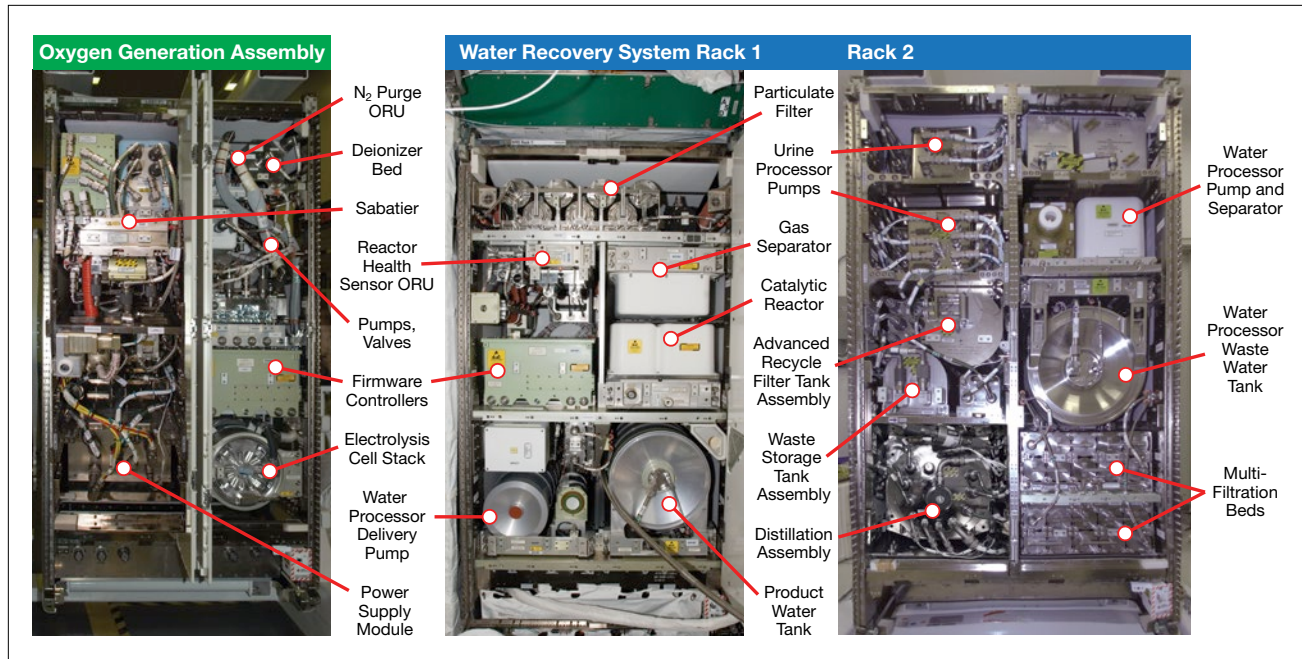
of water but also contains many organic and inorganic waste products including urea, chloride, sodium, potassium, and creatinine. The urine is treated with a chemical, called pretreat, to prevent the urea from crystallizing and potentially plugging the plumbing lines. A filter also removes any particulates that are left behind. Once in the UPA, the urine is pumped to the distillate assembly where the temperature is raised and the pressure is lowered to cause water evaporation. This evaporated water is compressed back into liquid form and is passed along to the WPA for further processing. The

remaining fluid, called brine, is sent to the Advanced Recycle Filter Tank Assembly (ARFTA) where multiple filters pull out any particulates as the brine is sent back to the distillate assembly where it joins with more pretreat urine and more water is pulled out.

The WPA is a key component of the water system on the ISS (Figure 8). First, water that is stored in the wastewater tank passes through a centrifugal pump called the Mostly Liquid Separator (MLS) similar to that used in the CCAA to remove air from the water. The water then



**Figure 8.** Schematic of the WPA. Water is drawn from the wastewater tank and passes through a filter that separates gasses from the water since gravity isn't present to facilitate natural separation. The water then passes through various filters including a heater to bake out impurities, a reactor to remove organics, and an ion exchange filter bed that will remove by-products of the organic reaction. Clean water is then stored in the product water tank.



**Figure 9.** Images showing OGA and the Water Recovery System racks.

passes through a particulate filter, followed by the Multi-Filtration Beds, which removes nonvolatile organics and inorganics such as soaps and salts. The water then is purified more in a catalytic reactor, which oxidizes low-molecular-weight volatile organics (this process uses small amounts of the  $O_2$  that is stored in the tanks on the airlock). Next comes the gas separator, which removes gasses created during the oxidation process. This gas needs to be removed to avoid clogging the fine filters downstream that are used throughout the potable bus systems. This gas is returned to the cabin to be breathed by crew, thus preventing the waste of any  $O_2$ . Small amounts of iodine are added to the water to prevent microbial growth from occurring. This clean water is then output to the Product Water Tank where it can be fed to the potable

water plumbing. Crews can extract water for drinking or rehydrating food via the Potable Water Dispenser (PWD) attached to this line. Wastewater from the UPA is also processed. People are often surprised that astronauts drink recycled urine. However, the processing is so good that what is left is virtually pure water. In fact, crew members have commented that the water tastes funny, which is actually a result of it being more pure than the water that is consumed on Earth. The OGA also uses the water from the potable water lines. The WPA can process 13 L (29 lbs) per hour.

As discussed above, the OGA takes water and produces  $H_2$  and  $O_2$ . Prior to the arrival of the Sabatier system, the  $H_2$  was vented overboard. With the arrival of the Sabatier rack in October 2010, the  $H_2$  would no longer be wasted. The rack takes

$H_2$  and  $CO_2$  and uses a catalyst at high temperature and pressure to produce water and methane via a chemical reaction first discovered by chemist Paul Sabatier. No further processing of the methane is possible on the ISS, thus it is vented overboard.

Although water is processed in a nearly closed-loop fashion (i.e., little water is lost to the system), management of this process requires a lot of diligence by the ETHOS team. Various factors are always affecting the balance in the system. For example, some crews drink more water than others; individuals also perspire and urinate at different rates. If any of the systems experiences a malfunction, part of the processing loop stops and input backs up. ETHOS can also tune the system to adjust water balance. For example, the temperature for the Low Temperature Loop system can be

lowered, which decreases the dew point on the station and, in turn, causes more water to condense out of the air. Another option would be to raise the temperature to reduce the amount of water collected via condensation. If the condensate tank is full but the WPA is not operating, the crew can drain the tank into a CWC, which later can be transferred back to the tank when it is empty. The OGA uses water to generate O<sub>2</sub>, which also has to be carefully balanced, thereby further complicating the process. The variables change often enough that water balance predictions are not accurate beyond 3 days in the future. Therefore, the ETHOS team must evaluate all these variables multiple times a day to ensure that the crews' upcoming plan properly accommodates the water balance needs. The racks that make up the Water Recovery System and the OGA are shown in Figure 9.

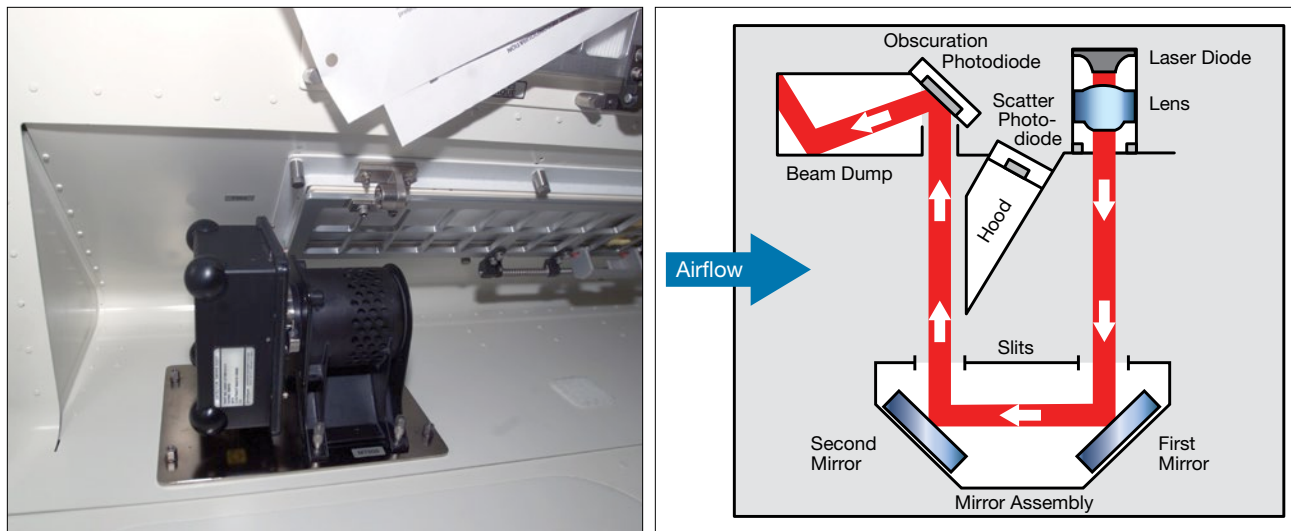
## Emergencies

In addition to maintaining life support, ETHOS must respond to emergencies. The three classes of emergencies on the ISS include fire, rapid depressurization (“depress”), or toxic chemical spill.

Fire is a serious threat in space. In the event of a fire on Earth, one option involves quickly exiting a structure. By contrast, astronauts who live on the ISS can leave the station only as a last resort, given this results in the costly loss of vehicle utilization. Fire detection and suppression is part of the ECLSS. The first step in preventing fires is assuring the materials used on the ISS are fire-retardant. Strict rules are enforced to ensure the space station contains nothing that is highly flammable. The most significant way to mitigate fires in space is to make it difficult for one to start; however, if a fire should occur, being in space helps. Fires in space are also difficult to maintain, due to weightlessness. On Earth, convection (the process of lighter,

warmer air rising while cooler gas falls due to gravity) can replenish the consumed O<sub>2</sub>, thus allowing the fire to continue to burn. However, in the absence of forced airflow in space, convection is nonexistent; once the O<sub>2</sub> around a fire is consumed, the fire will extinguish. Therefore, electrical parts of the ISS are usually located behind panels where airflow is not possible. If a fire should start for some reason, it will likely extinguish itself.

However, an electrical or chemical fire can still occur in a location such as a systems/payload rack or in the open cabin where there is regular airflow; therefore, the fire won't quickly extinguish. As a precaution, smoke detectors are placed throughout the ISS to alert the crew and flight controllers to a fire, much in the same way smoke detectors are used as a precaution on Earth. The detectors on the ISS are similar to many in terrestrial buildings. Laser light is monitored to see whether particles of smoke are blocking the light (Figure 10). Once smoke is detected, the software will automatically



**Figure 10.** Picture of a cabin smoke detector (left) and a schematic (right). Laser light bounces off of several mirrors into a photodiode detector. If particles of smoke are present, the beam will be obscured with a reduced brightness. Laser light will also scatter off the particles and into a second photodiode to ensure that a false alarm is not triggered by a single problem with the obscuration sensor.

annunciate a fire and sound the alarms throughout the ISS and on the ground in Mission Control. In addition to the smoke detectors picking up the event, if the crew sees or smells smoke, they can manually trigger an alarm via the caution and warning panel (see Chapter 5). When an alarm is annunciated, one of the first responses is for the software to turn off all fans and close the IMVs to help stifle the fire and prevent smoke from being transferred to other modules.

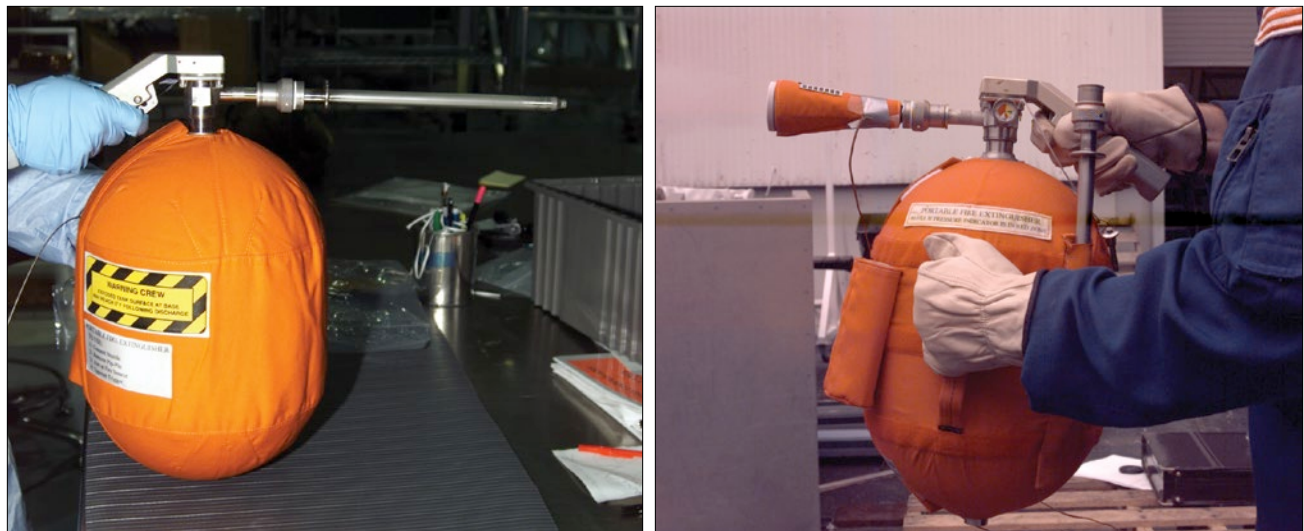
If a fire is detected by the smoke detectors, the crew will need to quickly fight the fire. For a fire detected inside a rack, the crew can remove power to that rack instantly by throwing a switch called the Rack Power Switch. Astronauts will then use a long rod attached to the CSA-CP to measure the smoke within the rack for a period of time. If the CSA-CP readings hold steady or decrease, the fire is declared to be out. Readings that continue to increase means the fire is still ongoing and needs to be extinguished. In this case, the crew will use a Portable Fire

Extinguisher (PFE)—i.e., an orange tank that contains about 2.7 kg (6 lbs) of CO<sub>2</sub>—and a long thin nozzle pushed through one of the small holes in the front of the rack to put out the fire. See Figure 11. By emptying the PFE into the rack, O<sub>2</sub> is displaced by CO<sub>2</sub>, thereby depriving the fire of a critical component needed to burn.

A wide nozzle that is installed on the PFE allows the crew to extinguish the fire in the event of visible flames inside the cabin. Smoke in the cabin can be dangerous to breathe; therefore, crew members will also don a Portable Breathing Apparatus (PBA) or a respirator (Figure 12). The small PBA tanks hold approximately 7 to 15 minutes of O<sub>2</sub> (depending on how well the mask fits to the individual's face as well as the personal respiration rate of the crew member); however, the hose can be attached to an O<sub>2</sub> port within the USOS and can pull O<sub>2</sub> from the O<sub>2</sub> tanks on the airlock, if additional time is needed. Since the time for a PBA is so short, and because O<sub>2</sub> is also introduced locally near the fire, use of the respirator

is preferable. Once the fire is extinguished, the flight control team in Mission Control assesses the recovery to clean the air. If few combustion by-products were created, they can be dissipated throughout the entire ISS volume and cleaned up via the TCCS. If large amounts of the by-products were created, the crew would set up a fan attached to a various filters to clean up the smoke and by-products. CO<sub>2</sub> from the PFE can be cleaned using the CDRA if the CDRA is in the same or nearby module.

If sensors such as the PCA detect a decrease in atmospheric pressure, it is likely that the hull has been breached and the vital atmosphere is leaking out. In this case, the computer systems will annunciate a rapid depressurization emergency alarm. Alternatively, if the crew members feel their ears pop, they can initiate a manual rapid depressurization using the caution and warning panel. The crew will then follow the emergency response discussed below to locate and isolate or repair the hole. As crew members will be losing their



**Figure 11.** PFE with rack attachment nozzle (left) and open cabin nozzle (right).



**Figure 12.** PBA (left) and respirator with fire cartridges (right). Different filters (orange boxes on either side) are attached to the respirator when it is being used after a fire or a toxic spill release such as ammonia.

atmosphere, they can find themselves in a situation in which they do not have enough  $O_2$  to maintain cognitive brain functions. If this occurs, they will don a PBA and isolate themselves in their return vehicle to prevent suffering from hypoxia—the result of not breathing enough  $O_2$ .

Toxic Atmosphere (ATM) represents the final emergency that the ECLSS supports, and which the ETHOS flight controller monitors. Various chemicals on the ISS are dangerous to the crew. Some of these chemicals range from mild irritants, such as the acid that can leak out of a damaged battery, to materials that can cripple or kill a crew member, such as the

ammonia used for cooling. Except in the case of ammonia breaching the IFHX (see Chapter 11), there is no automatic annunciation of a toxic spill. The crew will detect it either from sight or from smell, and then annunciate the spill via the caution and warning panel. As was the case for fire, the IMV system is isolated to prevent the chemical from being dispersed throughout the ISS.

Cleanup response to a toxic spill depends on what was spilled. All hazardous materials—i.e., HAZMATs—are logged into a database that lists the toxicity of every chemical used on the space station. Some are benign, but others

can be extremely deadly. The flight control team and crew look at the database to determine the toxicity of the spill and the appropriate response. Basic response supplies are found in the Crew Contamination Protection Kit (CCPK). Mild spills can be cleaned up with wipes and silver shield gloves, which prevent absorption into the skin. Dirty wipes and towels are put in multiple plastic bags and carefully sealed to contain the material. In a bad spill, the crew members will don a respirator (Figure 12) and use the CMS to determine the air quality. For a really bad spill, the module might have to be closed off.

## Emergency Response

The previous sections outlined the basic equipment available to detect or respond directly to one of the three emergencies on the ISS—fire, rapid depress, or toxic chemical spill. However, these emergencies require time-critical responses from the entire crew and ground, and are heavily practiced by both. The initial response is similar for all three: warn others, gather in a safe haven, and work the emergency response. To warn others means to push the appropriate caution and warning alarm if an automated one has not been initiated. This process is critical to alert other crew members, but it also allows automated software to stop fans and close the IMV system, thereby reducing smoke or toxic gas from spreading throughout the ISS. Communication is also critical between the crew and ground. In the case of an emergency, both the Russian and NASA mission control centers spring into action. The crew is primed for responding to these emergencies, but the ground helps the crew as much as possible.

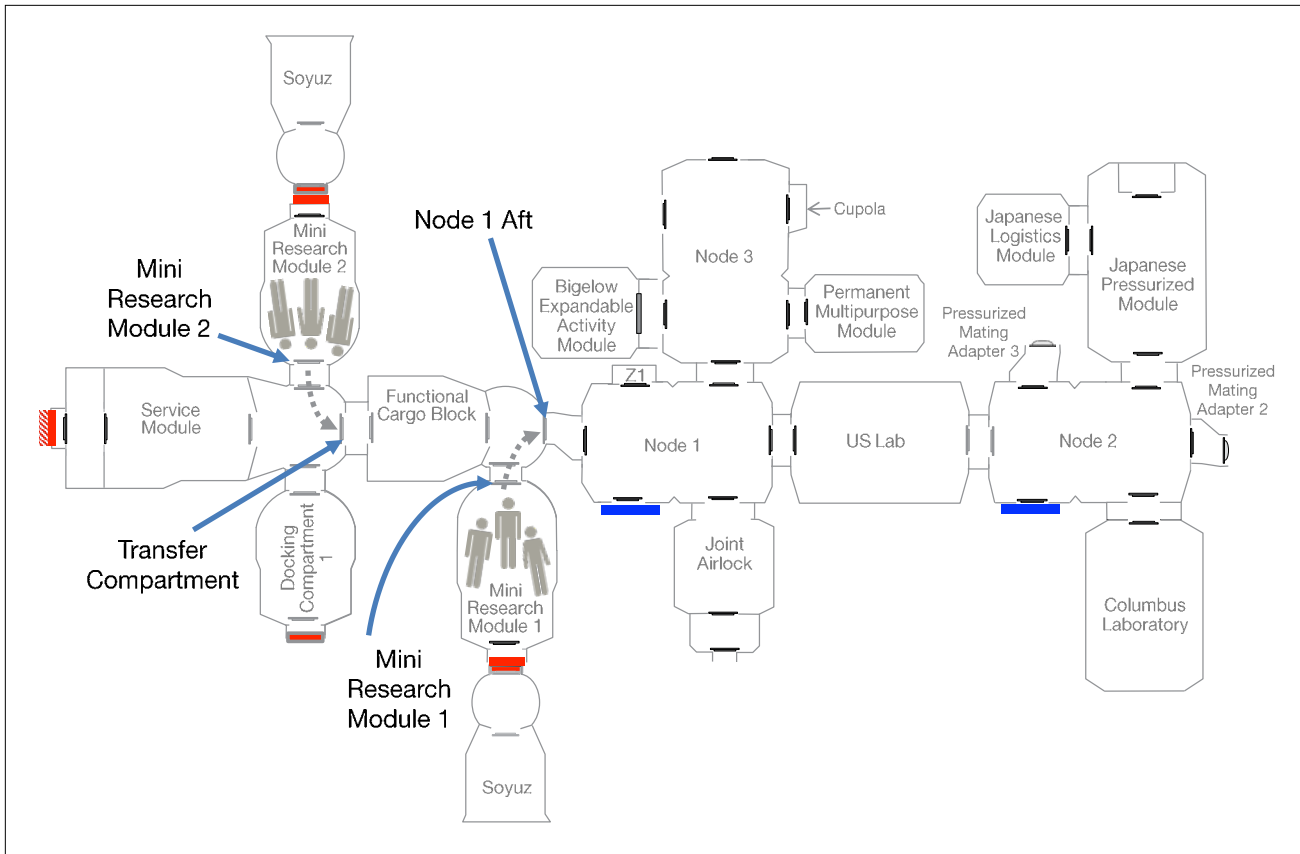
Usually, the crew selects the location of the central post computer in the RS as the safe haven muster point. This is chosen because it is near the Soyuz vehicles, which might be needed for a quick evacuation if the situation is serious and cannot be resolved. If there are flames in the cabin between the crew and the Soyuz, the crew will create a safe haven away from the fire and then fight the fire as quickly and safely as possible. Crew members never want to be cut off from their escape vehicle. Once

assembled, the crew will execute the appropriate response procedures, under the guidance of the commander. Generally, astronauts on the USOS use electronic procedures in English to perform their tasks, whereas cosmonauts use Russian procedures. However, emergency procedures are printed on paper—in what is called “the red book”—in case of computer or power problems. One page of the red book is in English and the facing page is in Russian so that any crew member can execute the steps under stress. One section of the red book is devoted each to fire, rapid depress, and toxic chemical spills.

In the case of fire, the crew will begin by taking samples of the air in the safe haven with the CSA-CP to ensure the area is safe. Once safety is established, a team will usually go toward the fire, taking air samples along the way as the team prepares to identify and fight the fire. Crew members will don a mask if dangerous combustion products are detected. The crew will then try to locate the fire. This can be easy if smoke is visible; otherwise, the crew will have to look on the Portable Computer System Caution and Warning display for help (see also Chapter 5). Such help can include indications of an alarm from a smoke detector or from a system, such as a failed piece of equipment or a power trip. Power is shut down in order to remove the ignition source or in case the event is caused by an electrical short or a smoldering wire. Simultaneously, the ground controllers look at the same data to help vector the crew to a likely location. Once the location

is identified, the crew will use a PFE to extinguish the fire, whether in a rack or in the cabin area. Using a PFE in an open cabin is a little more challenging in microgravity than on Earth: the spraying of the CO<sub>2</sub> will act as a jet engine, propelling the crew member in the opposite direction if his or her feet are not anchored. The crew will close the hatches and seal the module while the ground figures out how best to clean up the smoke in cases where the heavy smoke will put the crew at elevated risk.

The response to a possible depressurization event is initially the same. Once at the safe haven, crew members will estimate how much atmosphere is available. The US flight controllers have tools that tell them how quickly the air is escaping. The crew has access to a manovacuumeter—i.e., a handheld device that shows the pressure in real time—that can be used by timing how quickly the pressure is decreasing. For holes so large that only minutes are available, crew members will evacuate to their Soyuz and prepare to depart. The ISS is about the size of a six-bedroom house, thus the hole would have to be very large to necessitate a departure by the crew. A hole that measures 0.6 cm (0.25 in.) in diameter will cause the ISS to depressurize to the minimal atmospheric level for supporting human life (490 mm Hg, 9.5 psi) in about 14 hours, whereas a 20 cm (8 in.) hole will reach that level in about 50 seconds. If enough time is available, crew members will look for the source of the leak. First, they will enter the docking



**Figure 13.** Schematic of the ISS showing all the hatches. In the initial response, each three-person crew gets into the combined Mini-Research Module (MRM) with its Soyuz and closes the hatch indicated by the arrows to check whether that area is leaking. If crew members still observe a leak, they will isolate themselves to determine the location of the leak within the MRM or Soyuz and prepare to either evacuate or re-ingress the ISS, depending on the results. Alternatively, if no leak is identified, crew members will enter the ISS (as represented by the dashed lines) and close the transfer compartment or Node 1 hatches (represented by arrows). At this point, the crew should know whether the leak is in the RS or the US Segment. Once isolated to a segment, the crew will close various hatches in a methodical process to isolate the module that is leaking.

compartment attached to the Soyuz, close the hatch, and check the pressure to ensure the Soyuz itself is not leaking. Once the Soyuz has been deemed safe, the crew will move forward, dividing the ISS into sections and measuring the pressure to isolate the module that is leaking. For holes that are large enough, the pushing or pulling pressure on a hatch might clearly indicate the location of the leak. See Figure 13.

If a hole is isolated to a specific module but cannot be seen, the crew can use an ultrasonic leak detector and headphones to move around inside the module to locate the specific spot by listening for the faint sound of air escaping. The crew can use a couple items to patch the hole, once the leak is found (see Chapter 3). The hatches to the module are shut in cases where the hole cannot be located or the amount

of time before the crew would run out of air is too short. Eventually, the module will depress to a vacuum. Key systems may continue to operate, but anything that requires air for cooling or that is not rated to function in a vacuum (e.g., a laptop computer) will break and the ground flight controllers will power down the equipment in hopes that the module can be recovered and the equipment can be used again in the future.

The third emergency scenario is that of a toxic chemical release. In most cases, the cause would involve a chemical released from research equipment and would be cleaned up as described in the previous section. The most serious case is that of ammonia entering the cabin. This would happen if the IFHX (see Chapter 11) fails and the barrier between the outside ammonia and inside water breaks. In this case, poisonous ammonia would get inside, which can kill the crew in a matter of seconds. Once an ammonia leak is detected, the astronauts will don a PBA, remove any clothing since that could be contaminated, close the hatch between the two segments, and transition from the PBA to a respirator with ammonia filters. Since the IFHXs are located in the USOS, there is a good chance the RS will be safe. Shutting down the fans and IMV, which the software performs automatically when the alarm is initiated, will help prevent the ammonia from getting mixed into the RS atmosphere. Once in the RS, the crew will take a reading to determine whether the air is safe. If no ammonia is detected (i.e., ammonia concentration less than 30 parts per million [ppm]), crew members may remove their masks. If ammonia is detected in the RS at a level less than 1000 ppm, crew members will wait a few hours for the ammonia to diffuse throughout the RS, thus reducing the levels to a safe limit. If the readings show high ammonia levels (>1000 ppm), crew members will enter their Soyuz spacecraft and begin cleaning its atmosphere, or prepare for a return

to Earth. Since the Soyuz volume is so small, ammonia can be purged using the respirators. This is done by breathing in air through the filters of the respirator, thereby trapping the ammonia. If the Soyuz atmosphere contains too much ammonia (approximately 1200 ppm), the crew will not have enough filters to fully clean the Soyuz air and will have to quickly return to Earth. Note that these procedures will have to be updated when the commercial crew vehicles begin transporting astronauts to the ISS, mainly because the crew vehicles will be docked very close to the likely source of the ammonia—the heat exchangers in Node 2. Since this means the astronauts will have to pass through the highest concentrations of the toxic chemical to get to their escape vehicle, additional O<sub>2</sub> tanks and a scrubber that can remove ammonia from the atmosphere will be stowed on the commercial spacecraft.

## Conclusion

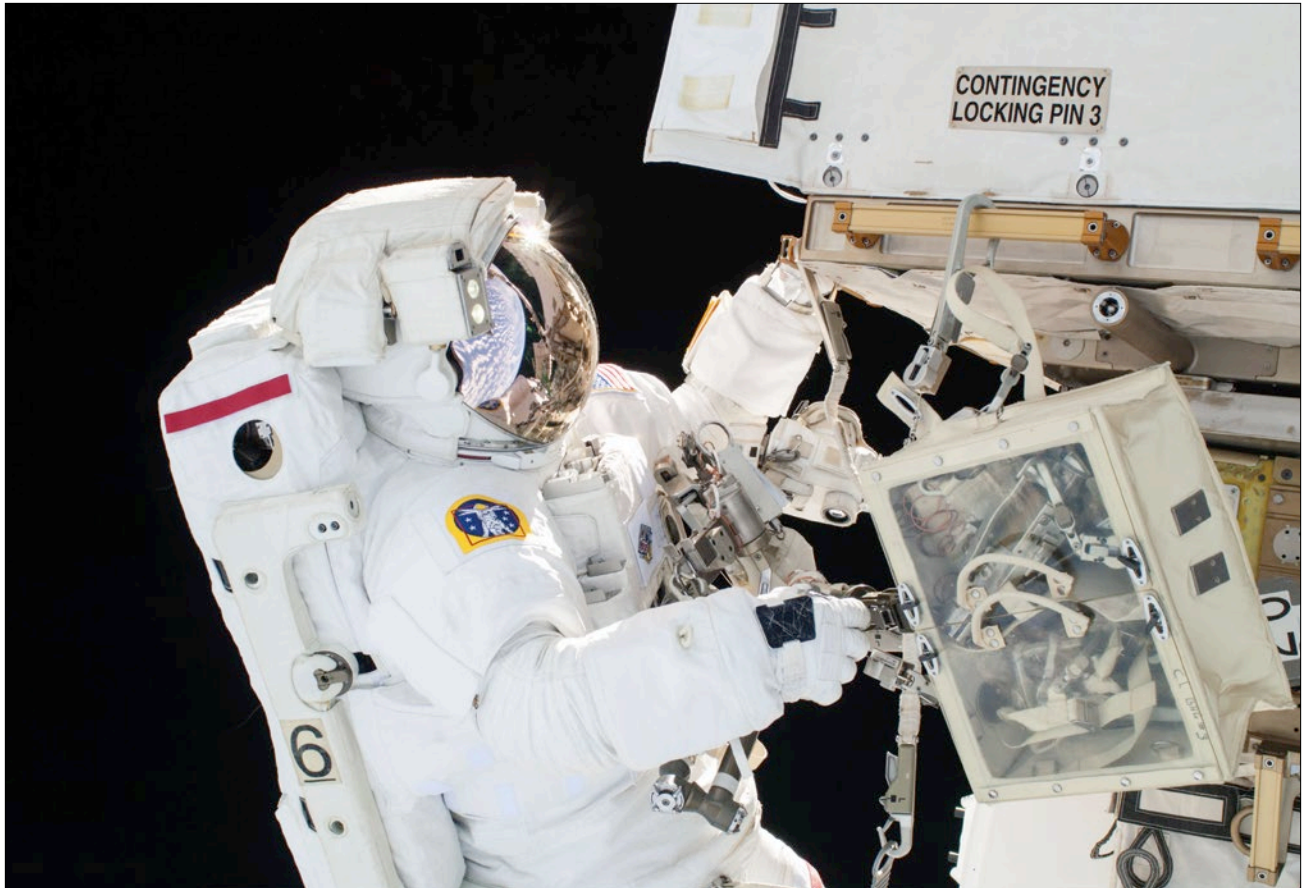
As the heart and lungs of the vehicle, the ECLSS allows crew members to focus on the important research they were tasked to perform. Emergency response is a priority on the ISS, as is maintaining a comfortable, productive environment in which humans can live and work. This effort requires a plethora of systems, subsystems, and experts to monitor and control all the elements necessary to not only survive, but also to thrive in the severe environment of space.







Chapter 20 Day in the Life:  
When Major  
Anomalies Occur



Expedition 38 astronaut Rick Mastracchio participates in the second of two spacewalks needed to change out a faulty ammonia pump on the International Space Station exterior.

**Blockbuster movie themes often tell a story about a major obstacle that must be overcome, with several exciting plot twists and difficulties that make tackling the challenge even more interesting.**

Experts from many fields come together to solve a problem, with basic needs such as sleeping and eating all but forgotten in their efforts to accomplish a perilous undertaking. When the issue is solved at the end of the movie, the audience breathes a collective sigh of relief, and everyone feels an enormous sense of joy and pride in a job well done.

*Well, working in Mission Control sometimes feels like that!* Along with the added bonus of occasional cheering and clapping. One dramatic human spaceflight example of this occurred when Mission Control saved the lives of the Apollo 13 crew. However, many extraordinary feats in the face of adversity have also occurred throughout the International Space Station (ISS) Program.

Imagine sitting in Mission Control, performing normal tasks and looking at data when something unexpected happens. The displays do not look like they usually do.

Warning messages in yellow and red splash across the screens, indicating issues with various systems. All the simulations come to mind, except this is not a simulation. This is really happening. The adrenaline kicks in. Time to figure out what happened and what can be done about it.

At least one failure of some kind usually happens during each shift in Mission Control—sometimes many failures. Typically, these failures are relatively minor. For instance, a laptop computer might lock up and the team might have to try a few things to get it working again. Other

times, a failure may significantly alter the crew's timeline for the day, as is sometimes the case with malfunctioning equipment needed for the task at hand. Or, the problem could be one that everyone dreads—an enormous failure that takes out a lot of the ISS functionality.

The initial flight control team reaction could last anywhere from a few minutes to a few days. Sometimes, extensive troubleshooting is required to test various fixes or even to simply diagnosis the problem. Some issues need observation over time to determine what is wrong, some need the engineering designer's advice, and some require complex ISS repairs that rely on the guidance of a large number of experts.

This chapter outlines one (of countless) ISS failures, and the reaction from Mission Control. This major failure occurred in the ammonia system in December 2013. The failure took out a lot of ISS capability and required many days to repair.

## **December 2013— Background**

Before discussing the failure, the anomaly recovery effort needs to be put in context. In 2012 and 2013, the ISS Program had begun successfully launching two different types of commercial cargo vehicles as part of its move to commercialize transportation to low-Earth orbit. The competing vehicle types were the Space Exploration Technologies Corporation (SpaceX) Dragon and the Orbital ATK Cygnus (see Chapter 14). However, in late 2013, SpaceX was in the process of designing an upgrade

to their Falcon launch vehicle, and commercial flights to the ISS would be limited for a few months to Cygnus cargo vehicles. Cygnus had performed a demonstration flight to the ISS; however, its first officially contracted cargo delivery was to launch in mid-December 2013. Orbital ATK was loading more than 1200 kg (2,645 lbs) of crew supplies, spare parts, research, and extravehicular activity (EVA) equipment. NASA wanted the cargo on the ISS, and Orbital wanted to fulfill its obligations and be paid for the flight. A period of “high beta” (see Chapters 7 and 9) was starting on December 30. During that time, the sun angle would not be favorable for solar array pointing needs and thermal effects on equipment such as antennas, which would result in the powering down of equipment. Docking during these phases is extremely challenging due to the limitations these constraints impose. Any slips to the Cygnus launch would need to skip over this period, placing the mission well into January, so managers were hoping its schedule would hold.

One of the key problems facing the space station team at the end of 2013 had to do with use of the spacesuits. The last US EVA in July 2013 had ended in a near fatality when water entered the spacesuit helmet of European Space Agency astronaut Luca Parmitano. The water covered much of his face and almost drowned him. After crew members performed some troubleshooting of the Extravehicular Mobility Unit (EMU), they determined that the water separator in the suit's Primary Life Support System had clogged, thereby backing up water that ended up dumping into the helmet (see sidebar in Chapter 17, *US Extravehicular*

*Activity 23 Water-in-Helmet Incident*). An official investigation was ongoing, and a root cause of the water separator clog had not yet been found. Something was contaminating the water system. If it was systemic in the water that was circulating inside the airlock, the source was possibly contaminating the entire fleet of spacesuits. After the incident, the EMU team designed an absorbent pad for the helmet interior that could be constructed by the crew on board, as well as a makeshift snorkel to allow for breathing from the body of the suit if water entered the helmet again. However, until the team found the source of contamination, the risk of drowning due to the same problem in any of the spacesuits was a real possibility for the crew. Engineers on the ground were in the process of assessing hardware from a previous mission and were seeing a complex water chemistry problem with no obvious cause.

The plans on board the space station for the month of December 2013 were filled with science, Cygnus cargo transfer operations, and a Russian Segment EVA on December 20—but that was all about to change.

## **“Orbit 2” day shift— Wednesday Dec 11, 2013**

It was a “standard” Wednesday for the ISS operations team, just after 8 a.m. Central Standard Time (14:00 Greenwich Mean Time), about the middle of the crew's day. The ground team was working with the crew in the airlock to get ready for installation of a new oxygen supply tank and were looking ahead to activities to prepare for the arrival

of the Cygnus cargo vehicle, which was scheduled to launch a week later (December 18). The Mission Control team was also preparing for an ISS reboost to a slightly higher altitude (see Chapters 7 and 8), so the team in Houston positioned a torn part of the Starboard Thermal Radiator Rotary Joint (TRRJ) to point away from the thrusters due to the forces generated when the thrusters fire during a reboost (Figure 1).

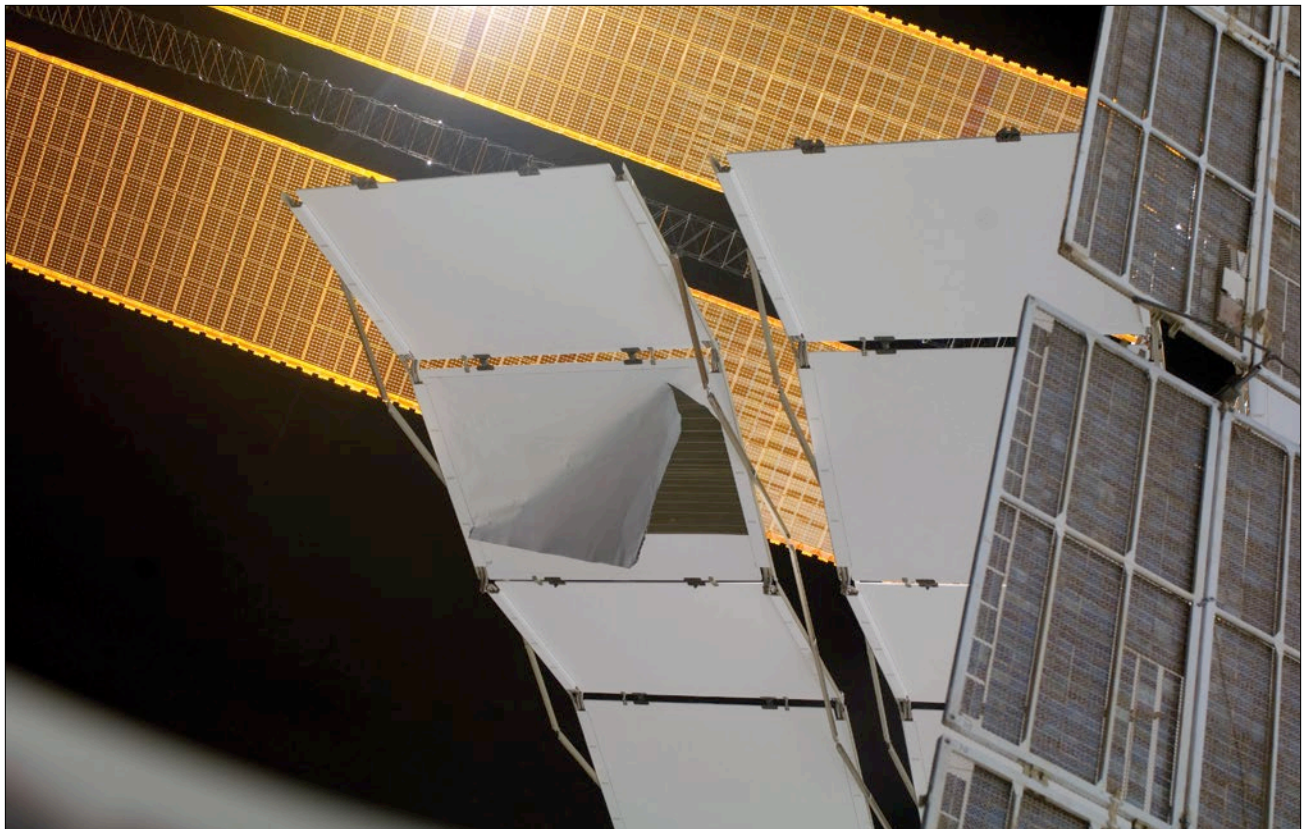
As comes around every so often, a relatively routine action kicked off an unforgettable moment for those in Mission Control. After moving the radiator, the team noticed warning indications.

Station Power, Articulation, Thermal, and Analysis (SPARTAN): “Flight, SPARTAN, I see the warning...” The flight controller in charge of the power and external cooling system, SPARTAN, announced the detection of an alarm to the team.

SPARTAN and the team quickly determined the external cooling system Loop A had shut down and was no longer circulating fluid to cool about half of the equipment on the ISS (see Chapter 11, Figure 6). Loop A is one of two external cooling lines circulating ammonia via an external pump. Loop A circulates ammonia through the starboard radiator (the other string, Loop B, pumps

fluid through the port radiator). An alarm sounded on board due to the significance of losing half of the external station cooling.

Everyone in all Mission Control Centers quickly scanned their data and looked for the right procedures to address these questions: What caused the problem? Are temperatures starting to increase? What is the correct response to immediately “safe” (i.e., protect) systems? The ground team had to quickly diagnose the warning messages and determine what had caused the shut down since about half of the US On-orbit Segment ISS equipment was cooled by that loop and could start to overheat. As

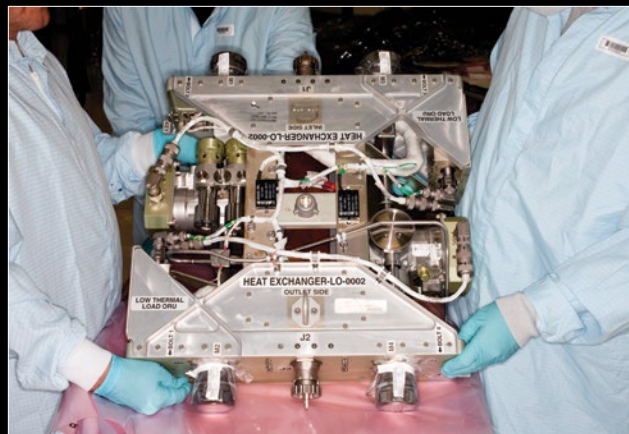
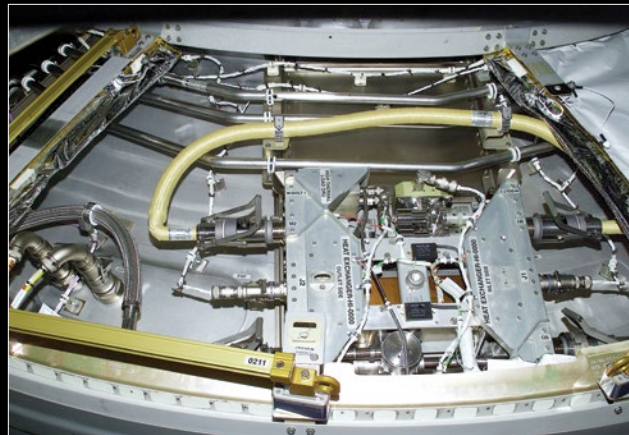


**Figure 1.** Torn sheet on the Starboard TRRJ. This TRRJ is usually pointed away from planned thruster firings unless the radiator needs to point in their direction for other reasons. The tear was first noticed in 2008. Since there is ample cooling, the sheet has not been repaired.

## A failure that could become deadly!

Some of the most critical interfaces on the ISS are called Interface Heat Exchangers, so named because of the ammonia cooling system and the internal water cooling system interface inside these units. The liquids do not mix; however, the design allows heat transfer from inside the ISS to outside the ISS. Heat is generated inside the ISS (e.g., from the many computers that run continuously). This heat warms up the water lines that circulate inside. At the surface of some key modules, the internal water and external ammonia lines come together in close proximity inside the heat exchangers, causing the internal heat in the water lines to transfer to the ammonia lines outside (some components outside the ISS are cooled with the ammonia lines). This ammonia is circulated externally to the radiators to “reject” the heat into space. See Chapter 11 for more system details.

The ground team and the astronauts worry that these units will fail. If the ammonia inside a heat exchanger is cold enough and ice-like slugs form, a frozen area in the heat exchanger could break the thin barrier between the external ammonia loop and the internal water loop, causing high-pressure ammonia to enter the more-delicate water lines and rupture them inside the ISS, spilling toxic ammonia into the atmosphere (see Chapter 19 for emergencies). When an external ammonia loop gets too cold, as it did in December 2013 when Loop A temperatures were low, flight controllers must carefully monitor temperatures and manage how and when a loop would be restarted. Fluid system experts and safety personnel also participated in the discussion over the 2-week timeframe of the Loop A repair to ensure safe loop operation relative to the Interface Heat Exchangers. (Figure 2.)



**Figure 2.** (Top) One of two heat exchangers installed on US Lab (EVA access panel removed). This unit allows for heat rejection from the internal water loops to the external ammonia loops. Heat exchangers such as this one are installed on several modules under silver access panels, and they are mounted on the pressure shell. Water in the internal cooling loop is fed through the shell to the heat exchanger and flows in close proximity to the colder external ammonia cooling loop for heat transfer. (Bottom) Spare Heat Exchanger on the ground. See also Figure 2, Chapter 11.

a smaller-scale comparison on Earth, imagine a car suddenly develops a problem with its radiator. The driver must determine when it is safe to pull over to the side of the road and turn off the engine to prevent it from

overheating to the point of incurring damage. All of the ISS equipment has to be assessed quickly to determine what needs to continue operating for a while, due to its criticality, and which temperature-sensitive items need to be

shut down as soon as possible. Flight controllers took immediate action to swap cooling sources for some critical equipment that could have overheated in a matter of minutes. They knew that loss of this loop would also mean

they would later have to prioritize which equipment could stay powered and which would need to be turned off to avoid over-taxing the remaining cooling loop with too much heat load.

The SPARTAN on console in Mission Control saw that the software intentionally turned off power to the pump that circulates the ammonia because the ammonia was getting too cold. The radiator, which was rejecting heat, deliberately reduced ammonia temperature; however, various parts of the entire loop had to be tightly controlled, temperature-wise (see Chapter 11). A Flow Control Valve (FCV) controls how much of that cold ammonia from the radiator enters the primary system. That valve is located in the same external box as the pump that circulates the ammonia in the external lines. In this case, the FCV did not move properly. The valve should have been closed at that point; however, it was not. Thus, too much cold radiator fluid was entering the primary system.

Within the hour, the flight control team restarted the pump and tried to control the FCV movement, but the loop remained too cold to flow ammonia through the heat exchangers that cool the internal water loops (see sidebar *A failure that could become deadly!*). The team continued to command the valve using various methods throughout the day, but to no avail. It seemed the valve indicated that it was in one position, but it was actually in another. The team moved the starboard TRRJ to a position that would warm it up, pointing at the sun and other structure; however, it still was not warm enough to allow use of the Loop A for cooling internal equipment.

While the team was troubleshooting Loop A, they also had to ensure the

most critical items received cooling. All of the powered equipment inside the ISS creates quite a bit of heat, and all of that heat was being put into Loop B rather than being dissipated into two loops. The team powered down equipment to reduce the overall amount of heat going into Loop B, and they also tried to get the Loop B port TRRJ fluid as cool as possible by pointing that radiator in a cold direction, away from the sun and structure. The Japanese and European module equipment is powered through Node 2, but one of the Node 2 internal loops could not be cooled. Therefore, some of the power to these modules had to be shut down to prevent overheating the Node 2 electrical equipment.

When the crew members' day was wrapping up, they helped by performing some of the power-down steps that required their intervention. Some of the activities for the next day were already looking impossible to complete, due to lack of powered equipment. They were informed of some of the changes before they went to bed. Meanwhile, the ground team still had a lot of work to do, including performing the ISS reboost while working with a cooling problem. On top of that, the team received a caution that the reboost did not complete due to an unrelated issue, so they had to quickly verify that the ISS was in a safe orbit!

The Mission Evaluation Room conducted meetings to involve the engineering team and they discussed what could possibly be done to correct the FCV problem. Meanwhile, the flight control team spent the next several hours trying unsuccessfully to move the valve, continuing to power down equipment and discussing what

would happen if something else failed. More on that below. This is about as busy as the flight control team can get, and the flight director was trying to keep everything from getting worse.

## Thursday, Dec 12, 2013

By the next day, the magnitude of the situation was weighing heavily on not only the console team but also a much bigger team of thermal experts, visiting vehicle programs, EVA experts, scientists, international partners, and other space station stakeholders. Loop A was still actively flowing, but the FCV was unable to be driven out of its cold position. The ammonia was about 30 Celsius degrees (54 Fahrenheit degrees) too cold. The team would either need to find a new way of warming up the ammonia in the loop, or have to perform a series of spacewalks to change out the valve.

Warming up the loop would be a challenge, but the operations and engineering teams had some ideas. Options included tricking the FCV by telling it to move outside its normal limits, warming the lines via heaters, or trying to unconventionally use a different radiator valve to modulate the temperatures enough to allow for some heat exchanger use.

Any of these “commanded from the ground” options would be desired over having to perform multiple EVAs. Spacewalks are risky and they require a lot of valuable crew time working with the spacesuits and tools. In this case, the time required for the EVAs to fix Loop A would probably mean the Cygnus mission would have to move to the following year. The spacewalks would entail change-out of a Pump



Module, which is a large external box on the starboard truss that houses the ammonia pump and the FCV. In 2010, the pump failed in a different way and was changed out via a series of three spacewalks.

To avoid the EVAs, the team's initial focus was on the "commanded from the ground" options. With the help of the Mission Evaluation Room members, the flight control team worked hard at characterizing the FCV failure and started to discuss other ways to control the loop temperatures. For example, they might be able to partially close a different valve—the Radiator Return valve—which would cause less flow from going to the cold radiator.

The ISS Program management and Flight Director's Office agreed that if these solutions were not looking feasible by morning, preparations for the EVAs would need to kick off. The chief of the Flight Director's office named a flight director to lead the effort that would be called "Team 4" (see sidebar, *Calling in the Reinforcements: Team 4*). A few flight directors and some other key personnel met to start discussing the big picture in terms of personnel and EVA timing.

One of the major tasks to discuss before starting to lead a big team was the timeline of events that would drive the deadlines for the team. December 30 through January 8 was the high beta period, which would not be good for either an EVA or a Cygnus mission, due to additional power-downs of equipment. Squeezing in repair EVAs before December 30 would be difficult. Even more daunting would be squeezing in the EVAs

## Calling in the Reinforcements: Team 4

The operations team and the ISS Program management may determine that it is necessary to formally call together a larger-than-normal group of people to resolve a time-critical problem "off-console." This type of team is called "Team 4" (see also Chapter 18), and it is led by a flight director. Team 4 is so named because it usually takes three shifts of teams to work 24-hour operations and an off-console team would be the fourth team. Although it implies a single shift of people, Team 4 usually requires two to three shifts over a few days to produce the required results. In the case of a Team 4 call-up, all available resources are made available, including facilities and the Mission Evaluation Room engineering personnel, hardware providers, and contractors. The lead Team 4 flight director brings recommendations for risk- or cost-related ISS decisions to program management and keeps the ISS Program informed throughout the course of events.

Since Team 4 is able to leave the flight control function to the other three teams, it can work on new procedures or perform analysis uninterrupted, work in mock-up facilities to determine what could be constructed on orbit, support the ISS Program meetings, or go try out spacewalk techniques in the Neutral Buoyancy Laboratory. Sometimes, members of Team 4 work together in a "War Room" setting, working in a dedicated conference room for hours each day with technical experts, discussing solutions or performing analysis. Team 4 is most successful when the console team is closely following the activities of Team 4. Team 4 creates official console documentation such as Flight Notes for new procedures and changes in the way the ISS should be operated. Team 4 members try to speak with the console team frequently throughout the day, and cell phones are always in hand in case console needs to reach someone on Team 4.

plus a Cygnus mission with launch, rendezvous, capture, and berthing. The Russian EVA that was planned for December 20 would need to be renegotiated if a series of US EVAs was added to the schedule or the Cygnus capture happened to fall on that date. Even if a way was found to wedge two major events into the same day, two dynamic events (e.g., EVAs and visiting vehicle captures) are not typically planned on the same day due to overall crew and ground team workload.

### Friday, Dec 13, 2013— Team 4 Is Called In

The next morning, the console team continued to struggle with ground commanding to control the ammonia loop temperature. It was officially announced that a Team 4 effort would be required to integrate all the teams and plan for EVAs. The Team 4 structure and logistics were discussed at a kickoff meeting. Several parallel efforts would be

occurring in various sub-teams, with seven key sub-teams listed below:

- **EVA:** Planning spacewalks to fully restore the system by replacing the degraded Pump Module with a new spare; this included writing down detailed steps to solve ammonia Quick Disconnect (QD) problems (connections in the system can be tricky) and planning for operations if the spacesuits become contaminated with ammonia
- **Cygnus:** Determining whether the Cygnus launch and berthing could be safely accomplished without Loop A fully restored, especially if the EVAs take a while to develop
- **Troubleshooting:** Continuing ground commanding to the system to see if temperatures could be controlled enough to allow for some temporary internal cooling, possibly allowing the Cygnus mission to occur before the EVAs, if needed
- **EMUs:** Continuing the investigation into what had caused the water separator to clog in an EMU, which spacesuit components would be best to use, and any other actions needed for the spacesuits
- **Analysis:** Predicting thermal and structural behavior of the systems with software modeling, known hardware performance and engineering experience; for example, predicting the behavior of the ammonia in the loop at different temperatures and pressures
- **Planning:** Planning the complex set of crew tasks and ground commanding sequence of events that would lead up to either a Cygnus-first scenario or an EVA-first scenario

- **Next Worst Failure:** Determining impacts to the ISS and actions in case of a “Next Worst Failure,” essentially planning for the worst thing that could happen next before the loop was fixed

The EVA officer, robotics officer, and SPARTAN briefed the expected operations for the spacewalks. It was by no means already figured out, but the teams had already changed out a Pump Module in 2010 and since then the procedures and crew training briefing had been updated and were fairly current.

The flight director leading Team 4 announced the preliminary EVA schedule (should EVA be required) that had been sketched out on a whiteboard by the team the day before. The first spacewalk would need to be planned for December 19, just 6 days later, with the second and third EVAs occurring approximately

December 21 and December 23, thus avoiding the high beta period starting December 30, and with the potential for three or more EVAs (Figure 3). This would leave a little bit of margin in the system if more time was needed between EVAs or if a fourth EVA was required. The EVA tasks that were involved are outlined Figure 3, assuming they could all be accomplished in three spacewalks.

Normally, EVAs are planned over the course of months or years. Although a Pump Module was changed out in 2010, several issues had occurred during the last change-out that would need to be resolved, and teams had estimated 16 days for the ground team and crew preparations needed to prep the suits and tools and study for the EVAs. Pulling it off in 6 days was difficult to imagine. With the holidays quickly approaching, many wondered whether they would be working instead.

## U.S. Spacewalks Overview

### EVA 1:

- Set up
- Degraded Pump Module preparation: Quick Disconnect (QD) demate, Pump Module Jumper install, electrical connector demate
- Spare Pump Module preparation: Multilayer insulation (MLI) open

### EVA 2:

- Remove degraded Pump Module, install on Payload ORU Accommodation (POA)
- Install spare Pump Module - bolts and electrical connectors only

### EVA 3:

- Finish spare Pump Module installation (Quick Disconnects)
- Slow degraded Pump Module
- Clean up

**Figure 3.** This was the plan going into the series of EVAs. Astronauts would conduct three spacewalks. However, some tasks could take longer than anticipated; thus, the team understood that up to four spacewalks could be needed to complete the repair.

## Expedition 38 Spacewalkers



**Rick Mastracchio**  
Flight Engineer  
ExtraVehicular 1

**Mike Hopkins**  
Flight Engineer  
ExtraVehicular 2

**Koichi Wakata**  
Flight Engineer  
Robotics Operator

**Figure 4.** The spacewalkers: Rick Mastracchio and Mike Hopkins. Robotic arm operator: Koichi Wakata.

Prior to launch, the Flight Operations Directorate and the ISS Program had determined who would perform spacewalks during the increment, if needed. In December 2013, the full six-crew-member team on board included US astronauts Rick Mastracchio and Mike Hopkins, Japanese astronaut Koichi Wakata, and Russian cosmonauts Oleg Kotov, Sergey Ryazanskiy, and Mikhail Tyurin. Prior to the mission, it had been discussed that if an EVA was required for an unplanned repair on the US Segment, Mastracchio and Hopkins would perform the necessary spacewalks and Wakata would operate the robotic arm (Figure 4).

### **Cygnus Considerations**

The Cygnus mission was scheduled to launch in a few days; however, Team 4 and the ISS Program management had not yet finalized whether the mission could take place

as planned or whether the ammonia loop needed to be working before Cygnus arrived. The health of the ISS would of course remain the priority, but until the decision to slip was required, the ISS Program wanted to keep their December launch options open. The ISS Program research team determined that the decision “need date” was a couple of days before launch day. The research group wanted to load the short-life science such as ants and a vaccine experiment into the Cygnus just prior to launch to ensure the science would last the entire mission. The Cygnus team had another couple of days to thoroughly consider their situation should Loop A not yet be repaired when they arrived. Among other things, the current loss of heat rejection from Node 2 meant that one of the two close-proximity communication units (see “Ship-to-Ship Communication Systems” in Chapter 13) between the ISS and

the Cygnus would not be powered up. If the one unit that was powered had a problem during rendezvous, the Cygnus vehicle would abort as it approached the space station. Also, after berthing, half of the power feeds to the berthing mechanism on Node 2 and half of the power feeds to Cygnus itself would not be available, thus exposing the mission and the ISS to bigger problems if the remaining systems experienced a failure.

### **Next Worst Failure Concerns**

The overall state of the ISS was concerning. The ability to perform science was severely impacted since a lot of equipment was powered off. This was especially true in the Japanese and European research modules. Some critical-but-redundant items were not operational. For example, the United States On-orbit Segment (USOS) oxygen generator was not being used; therefore, the station relied on the Russian oxygen generation system for the time being. Also, any time the ISS is not in an expected configuration, a lot of little-used or not-yet-created analysis comes into play—e.g., whether cooling loops can handle more or less heat load, and how long some boxes can sit in a certain environment without overheating.

To determine what level of risk the ISS Program was willing to accept and how quickly repairs needed to be performed depended on the answer to this question: “What is the worst thing that could happen right now?” These potential watch items were called the “next worst failures,” and some of them would put the ISS in a precarious position. A large team scoured the various scenarios, but the most significant

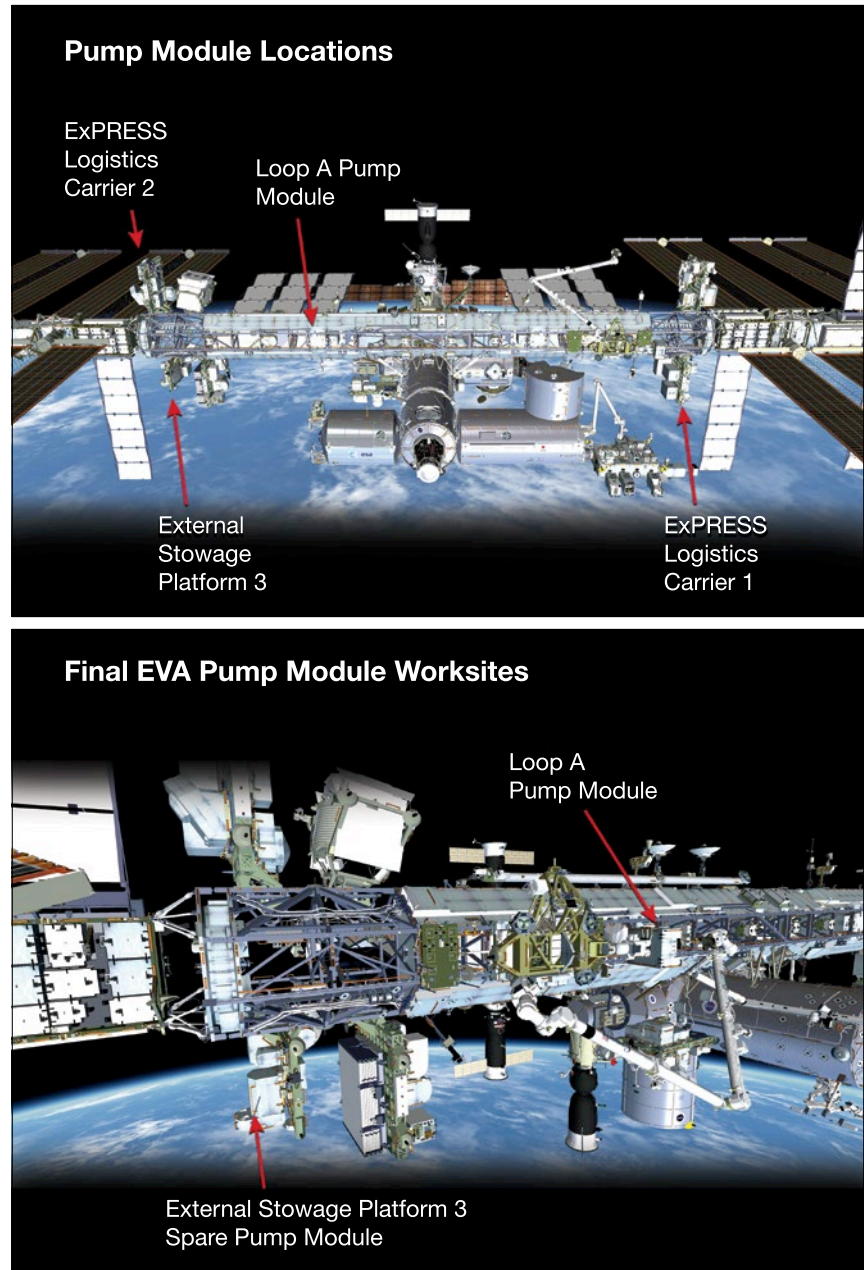
issue would be a subsequent failure of the Loop B pump (or failure of its power supply), which would cause a loss of heat rejection for all/most internal components on the USOS. This would mean all of the computers, pumps, lights, etc., would need to be turned off. There might be some available limited capability if power could be supplied via jumpers (such as extension cords) from the Russian Segment and cooling ducts could be set up to blow air from the Russian Segment to keep US components from overheating. However, the Russian Segment was not designed to support six crew members or cooling of US equipment for long periods of time. Also, we would have to rely on a Russian EVA using Orlan spacesuits to change out components on the other end of the ISS if the USOS airlock had to be powered down. The team would be extremely handicapped if the previously designed spacewalks using the EMU and Space Station Remote Manipulator System (SSRMS) could not be used for changing out a large Pump Module. Waiting to fix the current problem meant spending more time at risk that a problem could develop with the second ammonia loop, and a repair in that situation would be much more difficult.

### ***Extravehicular Activity Decisions***

Some important decisions would need to be made over the course of the next few days. With a lot of open questions flying around, “collapsing trade space” was needed so that the team did not spend too much time performing unnecessary work. Trade space referred to risk assessment of the pros and cons for each of the options. Narrowing the options meant less work and a faster end

result. In this case, the spacewalk crew members could spend a lot of EVA time stowing the degraded Pump Module neatly in a spot on the

truss, or they could throw it out into space and let it burn up on reentry through the Earth’s atmosphere. Each option trades some risk to the ISS

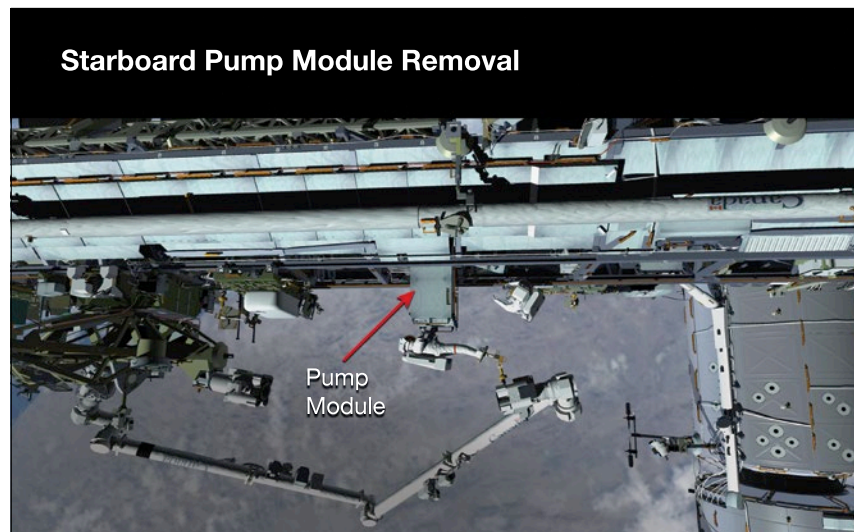


**Figure 5.** The degraded Loop A Pump Module was installed on the forward face of the truss on the starboard side of the ISS. The chosen spare was located on the External Stowage Platform #3, also on the starboard side of the ISS but below the failed pump (top). The going-in plan was that the two would eventually be swapped so that the degraded Pump Module would be placed on External Stowage Platform #3 (bottom).

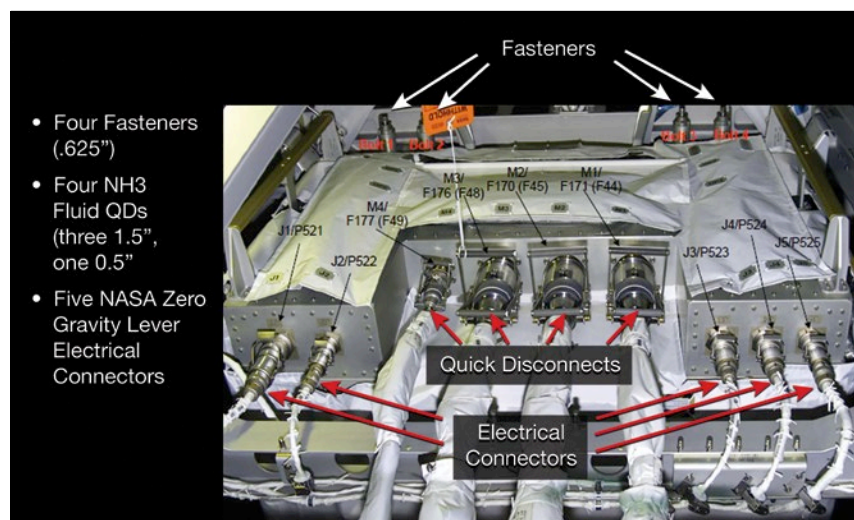
(e.g., What if the degraded spare could be re-used in some way later?), to the astronauts (e.g., What if water comes into the helmet again, and why were we unnecessarily spending time stowing this degraded pump?), or to the human population on the ground (e.g., What if the old pump does not fully burn up and a chunk hits a populated part of Earth?). The leadership reviewed the trades and worked to make decisions quickly so that the team could move forward with little wasted work.

One immediate decision needed was which spare Pump Module would be used to replace the degraded pump. Three spares were stowed on the ISS exterior, none of which was in the same place as during the 2010 EVAs. That decision had to be made later that day or at least by the next morning since it drove the robotics (e.g., to drive where the Mobile Transporter or the SSRMS was to be located) and EVA procedure development. As it became apparent after looking into the situation, the procedure development would be simplified if one spare in particular was chosen, which made the decision fairly easy. The chosen location was a starboard stowage platform that was “hanging” nadir from the truss (Figure 5). The location of the robotic arm also worked well for positioning one of the astronauts for the actual repair (Figure 6).

Another key decision the team worked on for the next several days was how low the ammonia loop pressure could be allowed to get for the EVAs. When the Pump Module was changed out in 2010, the EVA crew had a difficult time working to disconnect and connect the large stiff fluid lines between the Pump Module and the truss. As when filling



**Figure 6.** This graphical representation shows how the EVA crew would be positioned when removing the large Pump Module from the truss. The crew member holding the Pump Module would have his or her feet in a foot restraint and would be holding onto the handrails in front. The Pump Module was very large and the crew members could not easily see around it while holding on.



**Figure 7.** The crew would need to manipulate several interfaces on the Pump Module, including electrical connectors, bolts (“fasteners”), and fluid QDs, which open and close off flow to allow for disconnecting ammonia lines for the Pump Module change-out without fluid spraying all over the place.

a hose with water, higher pressures would make it more difficult for an EVA crew member to manipulate the lines. Lowering the pressure might significantly reduce the overall EVA time spent struggling with the QDs (Figure 7). In fact, if they struggled

too much, another spacewalk might be required, adding crew risk of exposure to water entering the helmet. On the other hand, if the system pressure dropped too low, cold slugs of ammonia could move around and damage the heat exchangers, thereby

introducing the potential for lethal ammonia to leak into the crew cabin (see Sidebar: *A failure that could become deadly!*).

A multitude of other decisions were going to be necessary. For example, several things went wrong on the last series of 2010 EVAs that were discussed in the standard post-event Lessons Learned meetings that now needed to be addressed, including one of the QDs that was stubborn on the last set of spacewalks. The crew had to literally bang on it with a heavy tool. What would happen if that technique did not work?

### ***New Extravehicular Mobility Unit Information***

The spacesuit teams received new data during the Team 4 effort, and they had to use this fresh information to sort out which spacesuit parts were the least likely to have clogged-up water separators if there was a problem with the water system of the entire fleet. The data were from some water filters that had been used on orbit, and they indicated that some filters were contaminated. These filters could have put particles in the system that made their way to the EMU water separator, creating the clog that backed up the water that spilled into the helmet. The EMU team started digging through the historical usage of those filters to determine which spacesuits had been exposed to those filters.

Ironically, a spare water separator was being flown to the ISS. However, it was loaded into the Cygnus vehicle and would not be available to install into an EMU as a clean spare until after the vehicle arrived. This presented yet another item to consider when looking at the order of events.

## **The Next 3 Days, Dec 14-16, 2013**

### ***Troubleshooting Team Progress***

The team at this point had turned its focus to trying to control the temperature of Loop A by partially closing off flow to the radiator using the Radiator Return valve. This valve is not intended to be stopped at incremental positions; however, the team members realized that they could start to move the valve and then remove power before it reached its final position with a goal to find a good partially open state for various temperatures. However, “fine” control this way would require new software to help with managing the temperatures through orbital day and night cycles and constantly changing internal heat loads. The initial short-term goal was to be able to bring the temperatures up high enough in Loop A to temporarily allow for the heat exchangers to be used for a couple of weeks. The team was on its way to doing so, but a large-enough temperature swing occurred and Loop A shut down again. The team was learning a lot about how to control the system, but it was becoming more and more clear that controlling the system with these techniques was just “buying time.” Eventually, the Pump Module would need to be replaced to keep the complexity down for operating the Thermal Control System. Unfortunately, as predicted, the thermal control experts were getting stretched very thin, working too many things at once.

### ***Cygnus Team Progress***

The Cygnus launch needed to slip for other reasons by 1 day, so it was announced that the mission

would launch on December 20. This provided some relief for the team. The increment, Cygnus, and engineering teams were working on how to fly the mission by having the crew install power jumpers to the communication system and berthing system to provide redundancy during rendezvous and installation, respectively. Once the Cygnus was berthed, the crew would have some new cooling fluid jumpers that could be hooked up to provide internal cooling for the power distribution boxes. Parallel planning for the Cygnus mission and the EVAs were going to come to a decision point around Tuesday evening. The crew and ground would begin operations that would be needed for either EVA or Cygnus and would preclude the other (e.g., moving the SSRMS to support the EVAs was required on Wednesday; jumper install for Cygnus occurred on Wednesday). These operations could possibly be pushed back a day or two, resulting in a delay in one of the operations; however, the loss of days in the increasingly tight window of opportunity this month was a concern.

### ***Extravehicular Activity and Analysis Team Progress***

The team uplinked preliminary procedures for the crew members to study, and they started getting the suits ready. The crew members got way ahead in their work, which kept the work that the ground teams had to complete as the long pole in the tent in terms of schedule.

To answer the question about whether a low ammonia line pressure is required for EVA crew manipulation of the lines, a team of EVA specialists, ammonia line experts, and astronauts

tested QDs at various pressures to determine how much pressure it would take to make it too difficult for the EVA crew member to perform the necessary line movements, disconnections, and reconnections. The team designed a test with an astronaut in a sling hanging from the ceiling of a large high bay to try out the manipulation as if he were in zero-gravity. The team wanted to know how much his body moved around when he was tugging and pushing on stiff ammonia lines. The problem with this decision is one often faced with spaceflight in that it has to be based on inexact testing and analysis. It would be ideal to have the microgravity, vacuum, and thermal conditions at which the ISS is flying to understand how the hardware actually moves. However, the test subject would need to be in space for that to occur. The terrestrial test is shown in Figure 8. The Neutral Buoyancy Laboratory—a large swimming pool for EVA training—could not be used since the high-fidelity lines and QDs, of which there are precious few in existence on the ground, would corrode in the water, thereby resulting in an inaccurate reflection of the forces and actions that astronauts would have to take in space.

The teams also pulled out real emergency gas masks and tested out how they could transition a crew member in a water-soaked EMU helmet to an emergency mask in the event ammonia contamination on the spacesuit is released into the ISS atmosphere after the spacesuit is inside. Water attracts the ammonia, so after repressing the airlock, the spacewalking crew member would close his or her eyes while an assisting crew immediately removed the EMU helmet, wiped the crew



**Figure 8.** Astronaut Doug Wheelock is testing fluid QDs at varying line pressures to determine which pressures make it too hard for the spacewalking crew to perform the task. Doug had performed a similar task while on a spacewalk in 2010, so he was the natural choice to perform the testing. A harness allowed his body to move left and right when he put in forces on the connectors, somewhat simulating the way it would be in space.

member’s face, and applied the emergency mask. One of the more-difficult decisions would be whether to hurry the crew members inside or have them wait longer at vacuum. When water in the helmet is not a concern, the ground would normally instruct the contaminated EVA crew members to stay at vacuum, letting any stuck-on ammonia “bake off”—a term that describes the sublimation of solid ammonia to vapor, which would effectively result in contamination lifting away from the spacesuits. If a crew member has water in his or her helmet, this might be more urgent than the ammonia contamination issue if the water moves onto the astronaut’s face. The worst case would be an astronaut who has ammonia contamination (which is fairly common) and water leaking into the helmet (which was thought to be more likely to occur if the water system was contaminated). Each case

might dictate a different response, but the team did its best to generalize and write down actions that could be used for quick decision-making for the different situations.

The concept of jettisoning the Pump Module (i.e., throwing it into space, where it would eventually deorbit and burn up in the Earth’s atmosphere) was one of those concepts that by Monday needed to either be pursued as the primary course of action or dropped as a concept. It was requiring a lot of work in parallel with a non-jettison option. Multiple team members came to the Team 4 meeting that day with good information and analysis related to jettisoning the degraded Pump Module. The latest trajectory analysis with new data showed that because of the mass, diameter, and external shape of the Pump Module and the various ways it could be

thrown by the EVA crew, it would be difficult to ensure the Pump Module would not come around and hit the ISS on a future orbit based on orbital mechanics. Also, it would need to be thrown in a direction that the EVA team thought would be tricky for the crew members, given the position of having their feet in the SSRMS. Reasons for keeping the degraded Pump Module were also surfacing in that the engineering team had been brainstorming ways to repair it in the future. So, the team turned off all work on jettison as part of a nominal course of action. Contingency jettison would still need to be worked in case a spacesuit emergency came up while the crew was holding the Pump Module.

## **Tuesday, Dec 17, 2013— Decision Day**

The Radiator Return valve effort was not looking as promising as the EVA effort, so the ISS Program management decided to commit to performing the EVAs. Because there was risk to the Cygnus mission with Loop A unable to control temperatures, the ISS Program made the decision that the EVAs would occur first and the Cygnus mission would launch in January so that it would arrive after the high beta cutout. A fresh complement of ants and vaccine-related science would be loaded into the vehicle just prior to that January launch.

At this point, a decision needed to be made regarding when the team would actually be ready for the first EVA. One key area in the “trade space” of the schedule was the issue of which spacesuit components

would be worn by the crew and how much time it would take to get them ready. Over the course of the previous few days, the team looked at which spacesuit components had been exposed the least to contaminated water filters over the past few months. Ironically, the Primary Life Support System (PLSS) used by Parmitano (designated “3011”) had recently had a lot of components changed out due to the investigation of the water in the helmet. With all of its new spare parts, PLSS 3011 was actually considered one of the cleanest (i.e., not as contaminated), and one of the recommended spacesuit parts to be worn for the EVAs to recover Loop A.

However, use of 3011 would require another 2 days to get the suit ready, which would push the first EVA to Saturday, December 21. Unlike the other recommended spacesuit, a spacesuit using PLSS 3011 would need to be resized using different modular parts to fit the current crew on board and change out of some of the components. The Hard Upper Torso and Secondary Oxygen Pack would need to be removed and replaced (see also Chapter 17). Hard Upper Torso sizing changes drive other changes, sometimes causing the need for different legs for the arms and legs, and the new parts and tweaks take time to put together. Despite the fact that a delay in the EVAs meant extending the risky posture of the ISS, the team agreed that these modifications and the use of that suit was the right thing to do to reduce the risk to the on-board crew.

The teams working the crew schedule and EVA were relieved to have 2 more days and a single, manageable plan.

## ***Working Out the Extravehicular Activity Details***

As for the EVAs themselves, the team continued testing and finalizing the details. Some of the EVA issues that had to be addressed throughout this effort are shown in Table 1.

An EVA team performed a test in the Neutral Buoyancy Laboratory to verify each crew member would be able to get back into the airlock quickly from each of the planned worksites in the event of another water-in-helmet scenario. The scenario is tricky since it combines several already-hazardous areas of spacewalking—turning off the water shuts off the cooling fan so the astronaut’s body might literally overheat; taking steps to prevent overheating involve purging the oxygen in the suit, which significantly increases the risk of running out of oxygen. The team walked through the scenarios for these specific locations and to determine whether the crew needed help getting back to the airlock. Crew members had to get to the airlock approximately 30 to 40 minutes after the emergency was declared, depending on how much energy they were expending and how hot they might get (e.g., if they are “riding” on the SSRMS, or working harder by using their hands to translate). Mission Control simulations such as those described in Chapter 10 were also planned—i.e., a water-in-helmet case, along with ammonia contamination and simulating what would happen if a Next Worst Failure occurred.

Also, the team began to discuss what would happen if the EVAs were not complete on time and whether an EVA would be needed to finish



**Table 1.** Examples of the Bigger Issues that Required Resolution by Team 4

#	Questions, Issues	Method for Resolution	Final Conclusion
1	Which of the three spare pump modules should be used?	Determine whether any are considered better spares based on their history; look at ease for robotics and EVA to access each of them.	Use spare on External Stowage Platform #3 on the starboard nadir truss.
2	Which spacesuit components are the safest to use (i.e., the least likely to cause water to enter the helmet)?	Look at the history for the components and choose the components that seem to be the least-contaminated.	Use PLSS numbers 3011 for Hopkins and 3010 for Mastracchio. 3011 use requires additional time for sizing and component changes.
3	Can the crew get back to the airlock safely if there is another water-in-helmet scenario?	Perform a test in the Neutral Buoyancy Laboratory to verify each crew member would be able to get back into the airlock quickly from each of the planned worksites.	Both crew members would be able to get to airlock in the required time from different places on the ISS
4	What will the team do if water enters the helmet, thereby necessitating quick airlock ingress, but the crew is contaminated with ammonia?	Write down expected responses based on the severity of the water or the severity of the contamination. Perform a test with a real emergency mask and EMU. Perform a simulation of such an event in Mission Control.	Test and simulation were instructive and procedures were created as a result. The final procedures were sent to the crew and published on the ground.
5	Should we jettison the degraded Pump Module or spend time putting it back in a stowage location?	Determine the ISS risk for jettison based on the potential for re-contact of the Pump Module with the ISS; determine the ease for the EVA crew to perform the jettison and EVA time it would save; determine future use for the degraded Pump Module, or whether it can just burn up in the atmosphere on the way down to Earth.	Jettison risk and complexity too high; decision made to stow the Pump Module and only jettison in case of quick crew emergency that would necessitate it.
6	Which ammonia loop pressure should be used—a very low pressure to help the EVA crew's work or a higher pressure to ensure the ammonia does not form pockets of vapor that could break the heat exchangers.	Perform testing with previously flown astronauts to determine which line pressures are acceptable. Have ammonia and safety teams analyze pressures that could result in heat exchanger damage. Choose a pressure that is acceptable to both, and best balances the risks.	Agreed on middle-ground pressure that would avoid concerns about heat exchanger damage but was a little more challenging for the EVA crew.
7	What if more EVA planning or execution time is needed, and an EVA slips into the high beta period?	If this happens, weigh the risk of the ISS situation at hand (with a Pump Module partially installed) against the risk of high beta (not having much power and thermal issues that might take down critical items such as video).	EVAs did not slip into the high beta period; therefore, no risk trade was required.

Pump Module installation during the high beta period that started December 30. The team was worried that the solar arrays would not be able to generate enough power where they would have to be placed, that external boxes would heat up too much, and that the Ku antenna

(see also Chapter 13) that supplied critical video during the EVAs would not be usable.

Two key decisions were made this day. The team would not know whether those decisions were good or bad until the EVAs were in progress. First, the EVA team had requested

the lowest possible line pressure to allow the EVA crew to perform operations with the fluid lines and QDs. However, the risk was that at low pressures below 12,412 mm Hg (240 psi), ammonia vapor could form near the interface heat exchangers (see sidebar: *A failure that could*

*become deadly!*). When the loop would be pressurized back to normal temperatures, a cold, “icy” slug of ammonia would move into those areas of vapor and freeze the interface heat exchangers, thereby breaking the heat exchanger and pushing toxic ammonia into the crew cabin. After much discussion, the team agreed to an ammonia line pressure that was a compromise reduced pressure of 9,309 mm Hg (180 psi) that would make it easier for the spacewalking crew manipulating the QDs but keep the loop pressure high enough to avoid too much vapor in the lines. The team would not know whether the pressure was low enough for the EVA crew until they were out on the spacewalk, and the pressure would take too long to be lowered, real-time, during the spacewalk. Therefore, another EVA would likely have to be added if the decision was conservative.

The other key decision had to do with how much testing would be done after the new Pump Module was installed. Ideally, the new pump would be checked out before the Pump Module (which did not contain any ammonia) was filled with ammonia from the tanks. The team did not want to waste the ammonia if for some reason the Pump Module that was installed would not work. However, because a real-time test would delay the EVA crew’s work, the decision was made that the test could be skipped if it looked as though other critical work could not be completed in time to fully close out the last EVA.

## Wednesday - Friday, Dec 18-20, 2013

With the exception of the EMU team that had to work on readying PLSS 3011, the members of the bigger team felt as though they were given a gift with two additional days. This meant they could focus on really dotting the i’s and crossing the t’s on the plan, and then get some rest before the first EVA. By this point, the team was very tired. When there is a problem and the dedicated folks in Mission Control need to solve it, they often spend 12 or more hours a day working the issue (and sometimes many more hours), and it can feel like finals week in school.

On Wednesday and Thursday, the ground team finalized the procedures and the crew readied the suits, tools, and themselves. It is difficult to even imagine the number of tools required to go out with the crew—

approximately 40 tethers were needed to hold the equipment onto the crew and the ISS (Figure 9). That number does not even include the tools needed to do the actual work. Multiple bags full of tools, as well as individual tools, were tethered all over the suits. Some of those tools were to be used in the EVA, and some were backup tools in the event the original tools encountered problems. Some of the tools were needed specifically for the difficult QDs for the ammonia system. The crew members were sent video on their operation. They practiced their use inside, and they had video conferences with their instructors to prepare for the use of these specialized tools.

Not all of the work is technical. Another task for the team is to support press conferences to brief the media about what is planned during spacewalks. Ideally, this would not take much effort since the technical



**Figure 9.** View of Rick Mastracchio during EVA 25. Several tethers can be seen on the front of his suit, with the cinch straps floating in various directions. These tethers are for general purpose use to attach equipment to the ISS structure, and equipment to his spacesuit tool caddy on his chest. A small, round trash bag is also visible.



**Figure 10.** A press conference held December 18, 2013, prior to the first spacewalk. From left to right: NASA moderator Josh Byerly, ISS Program Manager Mike Suffredini, Flight Director Dina Contella, and Lead EVA Officer Allison Bolinger.

issues that were resolved and what will be done on the EVA had been summarized. However, some overhead in preparing is needed to frame the situation for the public, just as any presentation takes some work (Figure 10).

An ISS Mission Management Team (IMMT) meeting was held on Friday to determine the readiness to proceed with the spacewalks (aka, a “Go or no Go” poll).

The Team 4 lead flight director briefed the IMMT on all the completed work and conclusions they had reached, and the international partners and representatives from all of the key organizations reported on their readiness and agreement. The IMMT then decided how to proceed forward.

The EVA timeline of events was ready to go. Mastracchio would “ride the arm” (i.e., put his boots into a foot restraint on the robotic arm) and

be the one to work with the difficult fluid QDs. If the QD operations went smoothly, he could move on to tasks planned for the second spacewalk to remove the massive failed Pump Module and temporarily stow it on the Mobile Remote Servicer Base System. Hopkins was going to “free float,” moving himself by grasping handrails and assisting Mastracchio. Wakata was the primary robotic arm operator, with Kotov helping him at the Robotic Workstation.

As the EVA approached, a concern surfaced that the Interface Heat Exchanger for the Columbus module (similar to the Lab version, shown in Figure 2) might have been accidentally exposed to freezing temperatures that could result in an ammonia leak into the internal thermal cooling system after activation of the new Pump Module during repressurization of the external loop. The concern was raised based

on thermal analysis, not actual temperature telemetry, so the team was trying to work through whether this was a real concern or if something was slightly wrong or overly conservative in the analysis. The team was also working on a Loop A repress procedure that accounted for this potential problem with the Columbus heat exchanger. However, everyone agreed that a solution would be found and the EVAs should continue.

The ISS Mission Management team agreed on Friday morning that everything was ready and the team was Go for the EVA on Saturday. To prevent fatigue during the critical EVAs, almost everyone working in the control center for Saturday’s EVA was encouraged to take Friday off to rest.

## **Saturday, Dec 21, 2013— The First EVA (ISS EVA 24)**

The moment had arrived for the first EVA. The night before, the lead EVA officer and flight director for the spacewalk marked up their procedures with notes such as “discuss EMU consumables” at various points, to agree in advance how often they would make standard calls and generally study what information exchange would be necessary. The team was fairly well rested and ready to go.

The crew worked efficiently that morning in “EVA prep” and prebreathe, with Wakata and Tyurin helping to suit up Mastracchio and Hopkins and allow them to purge the nitrogen from their blood by breathing pure oxygen before depressing the airlock (see Chapter 17). The EVA crew members tethered themselves

in the small crewlock, Wakata shut the hatch between the crewlock and equipment lock, and the crew performed a crewlock depress to vacuum. They opened the hatch around 6:00 a.m. Houston local time, about 10 minutes earlier than planned.

These types of events are a big deal in Mission Control, with photographers and, in this case, a videographer walking around in the room. The excitement in the crew members' voices could be heard as they experienced a spacewalk "live." Their helmet camera views as they looked at the Earth and took photos of each other could be seen. Their time in the spacesuit was limited—they would deplete their suit of consumables and be very fatigued at the end of the day—so every minute counted. The team in Mission Control was hypersensitive of time, since they might have the opportunity to get ahead on this first spacewalk and actually pull the Pump Module out of the truss to temporarily stow it. That would mean the new Pump Module could be installed and working with only one more spacewalk. Due to all the training and preparation, the flight control team might appear calm to the casual observer. However, everyone is on high alert and is highly vigilant. Figures 11, 12, and 13 show the crew and flight control team working the EVA.

A few curve balls were thrown at the crew and Mission Control during the spacewalk with respect to the tools, the Pump Module and its QDs, the spacesuits, and other space station items. For example, a foot restraint was difficult to remove from the location where it had been stowed for quite some time in the harsh



**Figure 11.** Koichi Wakata, representing the Japan Aerospace Exploration Agency, is shown "driving" the SSRMS at the Robotic Work Station in the US Laboratory during one of the EVAs.

space environment, but it eventually came free. Also, some of the fluid QDs (Figure 7) were difficult to manipulate, and one of them leaked a small amount of ammonia. This leak looked like floating snowflakes bouncing off of both spacesuits.

This occurred early enough in the spacewalk that the crew was outside a long time after this point, giving the ground team confidence that any ammonia had baked off. The flight director at the end of the EVA waived the Flight Rule that indicated a test



**Figure 12.** The ISS flight controllers during the first spacewalk to repair the faulty Pump Module. From Left to right: videographer, Flight Director Dina Contella, CAPCOMs Aki Hoshida and Doug Wheelock, and Lead U.S. EVA Officer Allison Bolinger.

should be done in the airlock to check for ammonia, due to the small quantity of flakes, length of time the ammonia had been “baking off” the spacesuit, and history with these test results in similar conditions.

The spacesuits generally performed well; however, at one point, Hopkins noted that some of the outer layer of material was missing from his left glove (see also Figure 6, Chapter 17). The ground team discussed the situation and the Flight Rules that govern glove damage and decided that the EVA could continue because the underlying bladder-protecting material had not been damaged. The outer layer was for better grip of the tools

and handrails, but the parts of the suit that held its shape and kept oxygen from leaking out were still intact.

The ISS also happened to experience some unrelated failures during the EVA. For instance, a smoke alarm rang on board the ISS. The ground team and crew had to quickly reprioritize what they were working on so that a potential fire could be discussed. The EVA crew members and their work were frankly lower priority than any possible fire. However, this smoke alarm was determined to be a false smoke indication in the Service Module. The smoke detector was set off when the crew kicked up

some dust while cleaning. Another unrelated failure occurred with the Carbon Dioxide Removal Assembly, which had to be manually restarted by ground command after a failure. These sorts of surprises kept the flight control team on edge. Thanks to similar training during simulations and similar failures seen in the past, the team was able to work through them fairly quickly and continue the spacewalk.

The entire team, including the seasoned crew, did very well that day, and there was time to pull the degraded Pump Module out of the truss and temporarily stow it in a designated location on the Mobile



**Figure 13.** Expedition 38 Flight Engineer Rick Mastracchio, as seen behind part of the degraded Pump Module that was removed from the S1 truss during EVA 24. He is temporarily stowing the Pump Module by guiding it to be grasped by its grapple fixture by a robotic end effector that is housed on the Mobile Remote Servicer Base System.

Transporter. By anticipating all of the critical decisions, and because nothing serious had happened, the team was able to actually get ahead of the planned schedule. That was half the content of the next EVA.

The team in Mission Control was excited to be this far along in repairing the space station. The EVA ended after 5 hours and 28 minutes.

After repress, one of the spacesuits had its water switch inadvertently

flipped to the “on” position for 1 to 2 seconds, causing water to flow into the sublimator when not at vacuum. The switch is normally protected with a “guard” to prevent bumping. In this case, the guard had yet to be installed. The EVA experts were worried that the sublimator would become damaged during the next EVA, since pockets of water that would not be able to evaporate in time might cause uneven freezing after airlock depress, thereby warping or cracking the sublimator. Mission Control had the crew open the flap on the EMU to allow for dry-out. The team realized it would be impossible to tell, before the next EVA, whether the sublimator would be acceptable since water could be hidden from the crew’s view.

The team quickly concluded that this suit could not be used, and had to choose from the on-board complement of modular suit components available. It was decided to resize PLSS 3011 for Mastracchio and then use a new suit sized specifically for Hopkins. This resizing had to be done before the next spacewalk.

### **Sunday and Monday, Dec 22-23, 2013**

The next EVA (EVA 25—the 25th increment spacewalk during the program) was originally intended to occur on Monday, December 23. However, with this additional suit resizing and given that the team had possibly reduced the number of EVAs from three to two, EVA 25 was moved to December 24. The crew and ground team slept in a little on Sunday, worked on suit resizing and changing tools, and generally preparing for EVA 25. Until that

point, everyone had been focused on the first spacewalk. Now, that same level of attention and diligence was needed to safely complete the job. The flight controllers and the engineering team provided their final approvals for the procedures to be used on this EVA, and the crew went to work studying these procedures and gathering the tools needed. The flight control team had a brief tag-up in a conference room in Mission Control on Monday to make sure everyone was well versed on the robotic arm movements, system changes, and EVA procedures.

Another issue related to hydraulically locking an ammonia line had come up. If a section of line heats up and no relief valve is in the system in that area, the line could break and become permanently damaged. Agreements had to be put in place about how many minutes the sections of line could be closed off during parts of the orbital cycle when the line could heat up, and whether the crew members had to shade the line with the shadow of their body or bags. The valve choreography (i.e., opening and closing) during the EVA had to be perfectly timed between the crew and the ground.

## **Tuesday, Dec 24, 2013— The Second EVA (ISS EVA 25)**

The team prepped again, as they had for the first spacewalk. Everyone came to the Houston control center on the morning of Christmas Eve, determined to recover Loop A that day. The main tasks of the EVA would include retrieving the spare Pump Module from the External Stowage Platform-3 and moving it to



**Figure 14.** Astronaut Mike Hopkins rides the robotic carrying the 354-kg (780-lb) ammonia Pump Module as the ISS flies over South America.

Source: NASA TV

the S1 truss. The crew would install it, bolt it in, and connect it to Loop A. EVA preparations went smoothly. The crew depressed and egressed the airlock about 15 minutes early.

On this spacewalk, Mastracchio would be the “free float” crew member. Hopkins would have the experience of riding on the arm and holding the Pump Module. Although one might imagine it as a relaxing ride, it is difficult to determine whether the boots are fully engaged in the foot restraint. This would be the first time Hopkins had been in a foot restraint on the tip of the 17-m (57-ft) robotic arm in space. He would have to indirectly feel that his boots were engaged, somewhat like a snow skier. However, the degree of difficulty was increased since he would not be able to see his boots due to spacesuit mobility, and because he would be holding a massive new Pump Module that would almost completely block his view, as seen in Figure 14.

The crew prepared the new Pump Module and moved it robotically over to the S1 truss installation, but the timeline was running about 30 minutes behind schedule. Because of this, the flight controllers on the ground were discussing what could be done with the timeline while Hopkins was maneuvering the Pump Module. To avoid the need for a third spacewalk, the ammonia fluid QDs had to be mated to allow the ammonia to flow through the system after this EVA. However, the crew could not perform this task late in the EVA without running the risk of the suit getting contaminated with ammonia just before crew members come into the airlock at the end of the EVA, when their consumables would be near their limit. The flight control team made the decision to have them mate the fluid QDs before they mated the electrical cables—a change to the procedure that the crew was able to accommodate.

Some interesting and nail-biting moments occurred in space and in the Mission Control during this part of the EVA. First, one of the critical fluid QDs would not come free from its temporary location, thus it could not be connected to the new Pump Module. The button that needed to be pushed on the top of the QD could not be depressed.

The crew and the ground team (Figure 15) worked together for quite some time on tool and other solutions, and eventually the QD came off. During the QD operations, some ammonia flakes came out, possibly causing suit contamination. However, when Mission Control sent a command to vent part of the system, a more-disturbing “cloud” of

flakes surrounded both Hopkins and Mastracchio, clearly giving them both a good chance of having ammonia on their spacesuits. The vent was not expected to have this effect, and the surprise was not welcomed. The crew looked at the spacesuits and did not see visible ammonia ice crystals on the suits. The ground team later had the crew members perform a

## An Unexpected Walk in Space

### Colonel Michael Hopkins, Expedition 37/38

December 11, 2013, started out like most days on station. Rick [Mastracchio], Koichi [Wakata], Oleg [Kotov], Sergey [Ryazansky], Mikhail [Tyurin] and I woke up at our normal times, ate breakfast, drank coffee, cleaned up, and began executing the scheduled activities. Later that day, a warning alarm sounded, which brought us all floating to one of our Personal Computer System computers to determine what had gone wrong and what actions we needed to take as crew. However, before we even had a chance to open any corrective procedures, Mission Control Center-Houston called with a message: “We see the warning on the board, no action for the crew at this time.” This direction from the ground team was not unexpected because they are often able to correct failures from their work stations allowing those of us on-orbit to continue executing the planned science experiments and maintenance events. This teamwork between the astronauts and flight controllers is one of the strengths of ISS operations because the on-board crew can focus on those items that can only be accomplished by someone physically located with the equipment in space, and the true system experts—i.e. the flight controllers—can diagnose and often resolve ISS issues with little to no actions from the crew.

My crewmates and I went back to the schedule and continued chasing the red line (the daily schedule uses a red line to indicate current time and astronauts try to complete their tasks before the red line crosses the

activity). We did not have a full understanding of the scope of the problem, and we certainly did not understand the flurry of activity taking place on the ground. However, later in the day when Mission Control asked for assistance with some hardware power-down and cross-coupling activities, we knew this was not a run-of-the-mill malfunction that would be resolved by morning Daily Planning Conference (see Chapter 2). At some point over the next couple of days, we had a video conference with our lead flight director, Judd Frieling, and he explained the scope of the malfunction with the Pump Module of one of the external cooling loops, and the multiple options being considered by the ground teams, including the launch of Cygnus or a possible EVA solution. Now we did not have any scheduled EVAs as part of our increment, particularly with the ongoing investigation of water in the helmet. Therefore, any discussion of going out the door was very exciting while also highlighting the gravity of the situation. We informed the ground team that we were ready to support all of the options, that we were well rested, and that activities supporting both Cygnus capture and EVAs should be put on the schedule and task list. As a crew, we were determined to do what we could to keep all options on the table as long as possible. This started a 2-week period that was probably the most exciting time of Expedition 38, and was described by Rick, who had previously flown on the Space Shuttle three times, as a close representation of one of those 2-week missions. Over the next 10 days, there would be no days off, and work would often start before breakfast and continue well into the evening.

During this time of uncertainty on the course of action, my crewmates and I often discussed the odds and made



“bake-out” (ammonia sublimation) outside the airlock (see Chapter 17).

After the Pump Module was installed and all of the umbilicals were mated, the ground began checking it out by sending commands to fill the system. Before the EVA, one of the major discussion points was whether the team would spend time doing a short

checkout of the Pump Module before filling it with ammonia. However, the EVA timeline was intertwined with the commands, and the EVA was running long. So, the flight director made the difficult decision to skip the checkout and starting filling the Pump Module full of ammonia instead, which saved EVA time but would mean a lot of ammonia would be

wasted if the new pump did not work. The SPARTAN on console sent the appropriate commands to do so.

The spacewalk ended with the team focused on a safe repress of the airlock. The crew performed a test in the airlock to see whether ammonia could be detected by passing airlock air through an ammonia-sensitive

predictions on whether we were going to capture Cygnus in December or whether we were going to repair the Pump Module with several spacewalks. In fact, the night before Mission Control informed us of the decision to delay Cygnus and execute the EVAs, we had put Cygnus capture as the more likely option, given our reading of the tea leaves. Despite owing the bookie, we were happy to have a decision, and life on board station took on a new intensity level. Though I was trained and qualified to execute any EVA required, the final days before hatch open were less stressful because my two USOS crewmates, Rick and Koichi, were a veteran spacewalker and a veteran robotic arm operator, respectively. Their calm demeanor and methodical preparation gave everyone confidence that the team would be ready to execute the Pump Module remove and replace (R&R) in a few days' time.

On December 20, 2013, after 9 days of intense evaluations, meetings, decisions, and preparation, and 1 day before the first of three planned EVAs, the ground team was able to give us the afternoon off. Everyone was ready and it was time to relax. Then fate intervened with a little humor, and another problem occurred on the ISS. The separator fan for the toilet in the US Segment failed and a replacement unit would have to be installed before the bathroom was open for business again. However, the flight control team wanted to keep our schedule clear since the EVA was the next day and we could use the toilet in the Russian Segment. For Rick and me, the failure was a blessing because it gave us something to do rather than float around and think about the spacewalk. After a quick conference

with the ground team, the flight director gave a go and we quickly had procedures on board to make the repair. So, the afternoon before one of the biggest days of our lives, Rick and I put on our plumber hats and repaired the space toilet.

The Pump Module R&R in December 2013 showcased what happens when NASA goes into crisis mode. The preparations were superb, the procedures well written, the decisions spot on. With assistance from our Russian colleagues, Rick, Koichi and I followed the detailed instructions from Mission Control and completed the repairs in two instead of the three EVAs we were planning for totaling almost 13 hours outside station. Problems were encountered during the course of the R&R, but in all cases a solution was found. Staring out the airlock hatch at the vacuum of space before my first EVA was one of the most profound moments I've ever experienced, and climbing back into the airlock after the second EVA with words from Mission Control that the R&R was successful was one of the proudest moments I've ever had. NASA's operation of the ISS provides daily reminders of the complexity of the job and the talent of the people assigned to the task. However, when a contingency happens, NASA takes it to another level and the accomplishments are truly amazing. For the crew of Expedition 38, the knowledge that the ground team put forward a super-human effort to solve the Pump Module failure drove us to do our small part with as much care and accuracy as possible, and together we had one of the best Christmas gifts ever.



**Figure 15.** The ISS flight controllers during the second spacewalk to repair the faulty Pump Module. From left to right: SPARTAN Flight Controller Bill Kowalczyk, the NASA videographer, Capcoms Aki Hoshide and Doug Wheelock, Flight Director Dina Contella, BioMedical Engineer Lawrence Baitland, and Lead US EVA Officer Allison Bolinger, with John Mularski assisting. On the far right: Norman Knight, chief of the flight director's office.

substance that would turn from yellow to blue in the presence of ammonia. The test turned out to be negative—no ammonia was present. During repress of the airlock, Mastracchio's communication cap lost audio in the right ear, giving the team even more to discuss.

The EVA ended up lasting 7 hours and 29 minutes, about an hour longer than was planned, but with an incredibly successful installation of a new Pump Module. The degraded Pump Module was left out on the truss, where it could remain for several months (Figure 13).

The ground team began activation of the new Pump Module and confirmed that it was working. The ground team told the crew of the successful results—the CAPCOM told them, "It's the best Christmas ever!" Smiles and handshakes were exchanged among the proud and exhausted teammates. For many of those who had been working the EVAs, Christmas was certainly going to be a happy day off.

## Tuesday, Dec 25, 2013, and Beyond

A lot of work remained to be done to bring the entire loop back up to full functionality. The ammonia loop was at a lower pressure than nominal, and it would take quite some time to bring it back to normal pressure. Christmas was not a day of rest. Many intricate procedure details had been worked out in terms of adding nitrogen to part of the system to increase the pressure of the ammonia (see Chapter 11), and the issue with the Columbus heat exchanger



**Figure 16.** (Top) Flight Director Dina Contella leads the team in Mission Control during the repair of the Pump Module on Christmas Eve, 2013. The spacewalking astronauts are visible in the live video downlink on the left. (Bottom) Full view of the team controlling the spacewalk.

would need to be worked around by isolating it from the system until it could be exonerated from any damage. The loop actually had to be completely shut down at one point so the crew could remove an internal

power jumper and reconfigure the power system.

The team eventually managed to work through the details and bring the ISS back up to full functionality. This

cleared the way for the later Cygnus mission, which launched successfully on January 9, 2014, after the high beta cut-out.

The lead Team 4 flight director summed up the teamwork that had occurred over the previous 2 weeks in this way:

*Throughout this huge team effort, I was incredibly impressed by those that I have worked with before and those that I hadn't yet met. This was international spaceflight at its finest! Thank you!*

And so went the story of just one of many human spaceflight victories. For each person in Mission Control in December 2013, the victory was fought on a personal front. Sacrifices were made by so many personnel and their families, upending their daily schedules, weekends, and vacations. But there was a personal reward, as well—the satisfaction of knowing they worked a really difficult human spaceflight problem and saw it end in success!



# Appendix

# Acronyms and Nomenclature

A	Approved	CO <sub>2</sub>	carbon dioxide
AC	Alternating Current	CRONUS	Communications Radio Frequency Onboard Networks Utilization Specialist
ACE	Atmosphere/Consumables Engineer	CRS	Commercial Resupply Services
ADCO	Attitude Determination and Control Officer	CSA	Canadian Space Agency
APAS	Androgynous Peripheral Attachment System	CSA-CP	Compound Specific Analyzer for Combustion Products
ARFTA	Advanced Recycle Filter Tank Assembly	CSG	Columbus Support Group
ARO	Automated Rendezvous Officer	CTO	Chief Training Officer
ATA	Ammonia Tank Assembly	CWC	Contingency Water Container
ATCS	Active Thermal Control System	DAM	debris avoidance maneuver
ATLAS	Atmosphere Lighting Articulation Specialist	DC	Direct Current
atm	atmosphere, standard		Docking Compartment
ATM	Toxic Atmosphere	DCS	Decompression Sickness
ATV	Automated Transfer Vehicle	DCSU	Direct Current Switching Unit
	Audio Terminal Unit	DDCU	DC-to-DC Converter Unit
AVENGER	Assembly Video Engineer	DJOPS	Degraded Joint OPERATIONs
BC	Bus Controller	DoD	Department of Defense
BCDU	Battery Charge/Discharge Units	DPC	Daily Planning Conference
BGA	Beta Gimbal Assembly	DVD-RW	Digital Video Disc-Rewritable
BME	BioMedical Engineer	EBCS	External Berthing Camera System
C&C	Command and Control	ECLSS	Environmental Control and Life Support System
C&DH	Command and Data Handling	eDPC	evening Daily Planning Conference
C&T	Communication and Tracking	EETCS	Early External Thermal Control System
C&W	Caution and Warning	ELC	ExPRESS Logistics Carrier
CAPCOM	Capsule Communicator	EMU	Extravehicular Mobility Unit
CATO	Communications and Tracking Officer	EPS	Electrical Power System
CBCS	Centerline Berthing Camera System	ESA	European Space Agency
CBM	Common Berthing Mechanism	ESP	External Stowage Platform
CCAA	Common Cabin Air Assembly	EST	External Stowage Platform
CCC	Contaminant Control Cartridge	ETCS	External Thermal Control System
CCPK	Crew Contamination Protection Kit	ETHOS	Environmental and Thermal Operating Systems
CCS	Command and Control System	EV	extravehicular
CDM	Carbon Dioxide Monitor	EVA	extravehicular activity
CDRA	Carbon Dioxide Removal Assembly	ExPRESS	Expedite the Processing of Experiments to the Space Station
CD-RW	Compact Disk-Rewritable	EXT	External
CIO	Cargo Integration Officer	FCR	Flight Control Room
cm	centimeter	FCT	Flight Control Team
CMG	Control Moment Gyroscope	FCV	Flow Control Valve
CMS	Chip Measurement System	FDIR	Failure Detection Isolation Recovery
COLBERT	Combined Operational Load Bearing External Resistance Treadmill	FGB	Functional Cargo Block
COTS	commercial off-the-shelf		

FIR	Fluids Integrated Rack	ITCS	Internal Thermal Control System
FWD	forward	ITS	Integrated Truss System
Gb	gigabyte	IV	intravehicular
GC	Ground Controller	JAXA	Japan Aerospace Exploration Agency
GGR&C	Generic Groundrules, Requirements, and Constraints	JEM	Japanese Experiment Module
GHz	gigahertz	JEM-EF	Japanese Experiment Module Exposed Facility
GMT	Greenwich Mean Time	JEM-PM	Japanese Experiment Module -Pressurized Module
GNC	Guidance, Navigation, and Control	JEM-RMS	Japanese Experiment Module Robotic Arm
GPC	General Purpose Computer	JOP	Joint Operations Panel
GPS	Global Positioning Satellite	JPM	Japanese Pressurized Module
GPRV	Gas Pressure Regulating Valve	JSL	Joint Station Local Area Network
Gr&C	Groundrules and Constraints	JSpOC	Joint Space Operations Center
GUI	Graphical User Interface	kbps	kilobits per second
HCS	Hub Control Software	kg	kilogram
HCZ	Habitation Control Zone	kN	kilonewton
HDR	high data rate	kPa	kilopascals
HEPA	High Efficiency Particulate Air	kW	kilowatt
HGA	high-gain antenna	LAB	Laboratory
HRS	Heat Rejection Subsystem	Lab C/O	laboratory checkout
HSG	Houston Support Group	LAN	Local Area Network
HTV	H-II Transfer Vehicle	LA-1 MDM	US Lab 1 Multiplexer/Demultiplexer
H <sub>2</sub>	hydrogen	lb	pound
H <sub>2</sub> O	water	LCA	Loop Crossover Assembly
HX	Heat Exchanger	LCD	Liquid Crystal Display
IAC	Internal Audio Controller	LCVG	Liquid Cooling and Ventilation Garment
ICC	Integrated Cargo Carrier	LDR	low data rate
IDRD	Increment Definition and Requirements Document	LEE	Latching End Effector
IEPT	International Execute Planning Team	LEO	low-Earth orbit
IFHX	Interface Heat Exchanger	LiOH	Lithium Hydroxide
IFM	in-flight maintenance	LRP	long-range planning Long Range Planner
IMMT	International Space Station Mission Management Team	LT	Low Temperature
IMV	Intermodular Ventilation	LTA	Launch-to-Activation
in.	inch	LTL	Low Temperature Loop
INT	Internal	LVLH	Local Vertical/Local Horizontal
IO	Information Only	MB	megabyte
I/O	Input/Output	MBM	Manual Berthing Mechanism
IP	Internet Protocol	MBS	Mobile remote servicer Base System
IR	In Review	MBSU	Main Bus Switching Unit
ISE	Integration and Systems Engineer	MCA	Major Constituent Analyzer
ISO	Integrated Stowage Officer Inventory Stowage Officer	MCC	Mission Control Center
ISS	International Space Station	MCC-H	Mission Control Center-Houston
		MCC-M	Mission Control Center-Moscow

MCC-X	SpaceX Mission Control Center	PDAM	Predetermined Debris Avoidance Maneuver
MCS	Motion Control System	PDGF	Power and Data Grapple Fixture
MDM	Multiplexer/DeMultiplexer	PFCS	Pump and Flow Control Subassembly
MER	Mission Evaluation Room	PFE	Portable Fire Extinguisher
Metox	metal oxide	PHALCON	Power, Heating, Articulation, Lighting Control
MHz	megahertz	PL	Payload
MLI	Multilayer Insulation	PLSS	Primary Life Support System
MLM	Multipurpose Laboratory Module	PLUTO	Plug-in-Plan and Utilization Officer
MLS	Mostly Liquid Separator	PMA	Pressurized Mating Adapter
MMC	Mission Control Center	PMCU	Power Module Control Unit
mm Hg	millimeters of mercury	PMM	Permanent Multipurpose Module
MMOD	Micrometeoroid and Orbital Debris	POA	Payload Orbital Replacement Unit Accommodations
MPEV	Manual Pressure Equalization Valve	PPCR	Planning Product Change Request
MPLM	Multi-Purpose Logistics Module	PPL	Pre-Positioned Load
MRM	Mini Research Module	PPRA	Positive Pressure Release Assembly
MSD	Mass Storage Disk	ppm	parts per million
MSS	Mobile Servicing System	PPR	Positive Pressure Relief
MT	Moderate Temperature	PRO	Power Resource Officer
MTL	Moderate Temperature Loop	psi	pounds per square inch
N1	Node 1	PTCS	Passive Thermal Control System
N <sub>2</sub>	nitrogen	PTR	Port Thermal Radiator
NBL	Neutral Buoyancy Laboratory	PV	PhotoVoltaic
NCS	Node Control System	PVCU	PhotoVoltaic Control Unit
NTA	Nitrogen Tank Assembly	PVM	Photo-Voltaic Modules
O <sub>2</sub>	oxygen	PVR	PhotoVoltaic Radiator
O3	Orbit 3	PVTC	PhotoVoltaic Thermal Control System
OBSS	Orbiter Boom Sensor System	PWD	Potable Water Dispenser
OCA	Orbital Communications Adapter	QD	Quick Disconnect
OCM	Orbital Conjunction Message	R&R	remove and replace
ODIN	Onboard Data Interfaces and Network	RAM	Random Access Memory
OGA	Oxygen Generation Assembly	RAVEN	Resource Avionics Engineer
OOS	On-orbit Operations Summary	RBI	Remote Bus Isolator
OPS PLAN	Operations Planner	RIO	Remote Interface Officer
OPTIMIS	Operations Planning TIMeline Integration System	RF	radio frequency
ORU	Orbital Replacement Unit	RFG	Radio Frequency Group
OSO	Operations Support Office Operations Support Officer	RGA	Rate Gyro Assembly
OSTP	Onboard Short Term Plan	RM	Redundancy Management
OSTPV	Onboard Short Term Plan Viewer	ROBO	Robotics Officer
PAS	Payload Attachment System	ROS	Russian Orbital Segment
PBA	Portable Breathing Apparatus	Roscosmos	Russian Federal Space Agency
Pc	probability of collision	RPC	Remote Power Controller
PCA	Pressure Control Assembly	RPCM	Remote Power Control Module
PCS	Portable Computer System	RPE	Resource Planning Engineer



rpm	revolutions per minute	THOR	Thermal Operations and Resources
RS	Russian Segment	TIG	time of ignition
RT	Remote Terminal	TITAN	Telemetry Information Transfer and Attitude Navigation
RTL	Ready to Latch	TMG	Thermal Micrometeoroid Garment
RWS	Robotics Workstation	TOPO	Trajectory OPERations Officer
SAFER	Simplified Aid for EVA Rescue	T-RAD	Tile Repair Ablator Dispenser
SARJ	Solar Alpha Rotary Joint	TRRJ	Thermal Radiator Rotary Joint
SAW	Solar Array Wing	T2	Treadmill 2
SDS	Sample Delivery System	TTCR	Trailing Thermal Control Radiator
SIGI	Space Integrated Global Positioning System/ Inertial Navigation System	TWMV	Three-Way Mixing Valve
S/G	Space-to-Ground	3-D	three-dimensional
SM	Service Module	UCCAS	Unpressurized Cargo Common Attachment System
SMCC	Service Module Central Computer	UHF	ultra-high frequency
SMTC	Service Module Terminal Computer	ULD	Ultrasonic Leak Detector
SOC	state of charge	ULF	Utilization Logistics Flight
SOP	Secondary Oxygen Package	UMA	Umbilical Mating Assembly
SPARTAN	Station Power, ARTICulation, Thermal, and ANalysis	UOP	Utility Outlet Panel
SPDM	Special Purpose Dexterous Manipulator	UPA	Urine Processor Assembly
SPOC	Station Power Operations Controller	USOS	United States On-orbit Segment
SRMS	Shuttle Remote Manipulator System	USTO	USOS Thruster Only
SSC	Station Support Computer	UTA	utility transfer assembly
SSIPC	Space Station Integration and Promotion Center	UTC	Coordinated Universal Time
SSG	SSIPC Support Group	LIIBM	Russian Segment Central Computers
SSMMU	Solid State Mass Memory Unit	V	volt
SSN	Space Surveillance Network	VES	Vacuum Exhaust System
SSRMS	Space Station Remote Manipulator System	VRA	Vent and Release Assembly
SSU	Sequential Shunt Unit	VRS	Vacuum Resource System
STARCOM	STATION Radio frequency COMMunications	VVA	Visiting Vehicles Officer
STCR	Starboard Thermal Control Radiator	VV DYN	Visiting Vehicle Dynamics
STP	Short Term Plan	WHC	Waste and Hygiene Compartment
STS	Space Transportation System	WIF	Worksite Interface
SVS	Space Vision System	WLP	Weekly Lookahead Plan
TBA	Trundle Bearing Assembly	WPA	Water Processor Assembly
TBD	To Be Determined	XPOP	X-Perpendicular Out of Plane
TCA	Thermal Control Radiator time of closest approach	YPR	Yaw, Pitch, and Roll
TCCS	Trace Contaminant Control System		
TCON	Thermal Control		
TCS	Thermal Control System		
TDRS	Tracking and Data Relay Satellite		
TEA	Torque Equilibrium Attitude		
THC	Temperature and Humidity Control		

# References

Castel, F. Novelli, A. *ATV The European Spaceship: Stories Behind The Scenes Of An International Success*, The European Space Agency, 2015.

Catchpole, J.E. *The International Space Station: Building for the Future*, Springer-Praxis, 2008.

Harm, D., Ruttley, T. *Research in Space: Facilities on The International Space Station*, NASA, NP-2009-08-604-HQ, 2012.

Herd, A., Dempsey, R., van Leeuwen, W. "Mission Control Center Design and Operations," in *Safety Design for Space Operations*, Editor in chief: Sgobba, T. Editors: Allahdadi, F.A., Rongier, I., Wilde, P.D. The International Association for the Advancement of Space Safety, Butterworth-Heinemann, 2013.

Houston, R., Heflin, J.M. *Go, Flight!: The Unsung Heroes of Mission Control, 1965–1992*, University of Nebraska Press, 2015.

Kraft, C. *Flight: My Life in Mission Control*, Dutton Adult, 2001.

Kranz, G. *Failure Is Not an Option: Mission Control From Mercury to Apollo 13 and Beyond*, Simon & Schuster, 2000.

Ryan, C. *The Pre-Astronauts: Manned Ballooning on the Threshold of Space*, Naval Institute Press, 2003.

Uhlig, A. Nitsch, J. Kehr, H. *Wie Columbus fliegen lernte*, Thomas 2010.

## Selected Readings

Barker, D. *International Space Station: 1998-2011 (all stages) Owners Workshop Manual*, Haynes Publishing, 2012.

Burrough, B. *Dragonfly: NASA and The Crisis Aboard Mir*, HarperCollins, 1998.

Chamitoff, G., Vadali, S.R. *Lessons Learned from More Than 50 Years in Space*, AIAA Press, 2018.

Jean, P.M., Braithwaite, T.H. *Canada's Human Presence in Space: Past, Present and Future*, IAC, 2014.

Johnson, M.P. *Mission Control: Inventing the Groundwork of Spaceflight*, University Press of Florida, 2015.

Lunney, G., et al. *From the Trench of Mission Control to the Craters of the Moon: Stories from the Men of Mission Control's Flight Dynamics Group: The Trench*, CreateSpace Independent Publishing Platform, 2011.

*Reference Guide to the International Space Station: Assembly Complete Edition*, NASA, NP-2010-09-682-HQ, 2010.

RF Spectrum: <http://kalonjiperry.wordpress.com/2014/04/30/rf-spectrum/>

## General References on the International Space Station

Current overview with reference material, photographs and video of the ISS:

[http://www.nasa.gov/mission\\_pages/station/overview/index.html](http://www.nasa.gov/mission_pages/station/overview/index.html)

Facts and Figures of the ISS:

[http://www.nasa.gov/mission\\_pages/station/main/onthestation/facts\\_and\\_figures.html](http://www.nasa.gov/mission_pages/station/main/onthestation/facts_and_figures.html)

Research on the ISS:

[http://www.nasa.gov/mission\\_pages/station/research/experiments/987.html](http://www.nasa.gov/mission_pages/station/research/experiments/987.html)

Orbital debris shielding:

<http://orbitaldebris.jsc.nasa.gov/protection>

Reference Guide to the International Space Station:

<https://www.nasa.gov/sites/default/files/atoms/files/np-2015-05-022-jsc-iss-guide-2015-update-111015-508c.pdf>

## NASA Technical Publications

Bond, R.L. "Application of Skylab Workday Analysis to Future Programs," JSC 12856. Johnson Space Center, Houston, TX. 1977.

Hornstein, R.S., Shinkle, G.L., Weiler, J.D., Willoughby, J.K. "An Innovative Approach for Distributed and Integrated Resource Planning for the Space Station Freedom," 41st Congress of the International Astronautical Federation, Oct. 6-12, 1990 (IAF-90-084).

Korth, D.H., Leblanc, T.P., "International Space Station Alpha Operations Planning," 3rd International NASA Workshop on Planning and Scheduling for Space, Oct. 27-29, 2002.

Kranz, E.F., "STS Flight Operations – Concept Versus Reality," AIAA Shuttle Environment and Operations Conference II, November 13-15, 1985.

McCormick, R.J. "International Space Station Execution Replanning Process: Trends and Implications," AIAA SPACE 2007 Conference and Exposition, Sept. 18-20, 2007 (AIAA 2007-6241).

Smith, N., Van Cise, E. "Contingency Planning for Removal and Replacement of Critical Equipment During Stage Extra-Vehicular Activity," AIAA SpaceOps Conference, 2008. <http://dx.doi.org/10.2514/6.2008-3287>

Van Cise, E., Kelly, B., Radigan, J., Cranmer, C. "Experiences with Extra-Vehicular Activities in Response to Critical ISS Contingencies," AIAA SpaceOps Conference, 2016, <http://dx.doi.org/10.2514/6.2016-2462> "Space Station Operations Planning" presentation for New Flight Director training. Updated 2014.

Watson, J., Ivins, M., Robbins, W., Van Cise, E., Cunningham, R., Rust, R., Curell, P., Roy, W. "Supportability Concepts for Long-Duration Human Exploration Missions," AIAA SpaceOps Conference, 2003, <http://arc.aiaa.org/doi/abs/10.2514/6.2003-6240>

Biomedical Results from Skylab, NASA SP-377, NASA Lyndon B. Johnson Space Center, 1977.

Chapter 2: Flight Control Experiences, pp. 20-21

Chapter 3: Skylab 4 Crew Observations, pp. 22-26

Chapter 4: Skylab 2 Crew Observations and Summary, pp. 27-29

Chapter 17: Crew Efficiency on First Exposure to Zero-Gravity, pp. 155-162

Lessons Learned on the Skylab Program (JSC-09096 and NASA-TM-X-72920), July 18, 1974.

NASA Technical Note MSC-05296 Apollo Experience Report - Flight Planning for Manned Space Operations, January 1972 (NASA S-319).

# Acknowledgments

*The authors would like to thank numerous individuals and organizations for their support in creating this book. We were especially fortunate to draw upon the experience, insight, and resources of the following individuals (unless otherwise noted, all work for NASA at Johnson Space Center):*

Sarmad Aziz (European Space Agency), Dr. Michael Barratt, Bill Barry (NASA Headquarters), Brad Bell, Ray Bigonnesse, Allison Bolinger, Timothy Braithwaite (Canadian Space Agency, Johnson Space Center), Kyle Brewer, Curt Carlton (Boeing), Donald Carter (Marshall Space Flight Center), Traci Charles, Bryan Corley, Philip Curell, Amy Dill, William “Bill” Ehrenstrom, Edward Fein, William M. Foster, Susan Freeman (Boeing), John Garr, Leslie K. Goss, Jose Guzman, Jean Haensly, Garrett Hahn, Wayne Hale, James Hartsfield, Victor Herod, Kyle Herring, Alexandros Kanelakos, Ginger Kerrick, Gary Kitmacher, Amit Kshatriya, Roger Launius (Smithsonian Institution), Dorothea Lerman (University of Houston Clear Lake), Dwight Link (Boeing), Stephanie Martin (Kennedy Space Center), Joshua McQuinn, Evelyn Miralles, Michael Misiora, Alexander Nitsch (European Space Agency), Dwight Osborne, George Palacios (Boeing), Robert Pickle, Todd M. Quasny, Kyle Richard, Michael Rodriggs, Emily Schulte, Donna Shafer, Kirk Shireman, Debra Simmons, Joseph Simon, Dr. Philip Stepaniak, Arthur Thomason, Barry Tobias, Thomas Uhlig (DLR), Paula Vargas, Jessica Violetta, Lisa Voiles, Michael Way, Mary Wilkerson, Rebecca Wright, German Zoeschinger (DLR)

For management, contract, financial, and printing support, we appreciate the outstanding efforts of Vicki Cantrell, Rosalie Carpenter, Susana Grossman, Julie Karr, Geraldine Martisek, Julius Mayhorn, Marshall Mellard, Chrystal Nevels, Kathy Padgett, Jalisa Sims, Sherrill Smith, Kristin Tauber, and Chrystal Wiseman.

The authors are grateful to Catherine “Cat” Bole’s careful review for export control compliance.

Special thanks also to the Canadian Space Agency for providing graphics and data.

Much gratitude to Helen Lane, for her editorial expertise and contribution, and to Paul Hill and Brian Kelly for their gracious support and vision.

We also gratefully acknowledge the guidance and support of Susan Breeden for technical editing, Cynthia Bush for illustrations, and Perry Jackson for graphic design and layout.

# About the Authors

*This book was written by flight directors working on the International Space Station (ISS) Program. Collectively, the authors have nearly 45,000 hours sitting in the flight director chair in Mission Control while working numerous Space Shuttle assembly missions, visiting vehicle dockings and undockings, software upgrades, and both Russian and American spacewalks. In keeping with the tradition of the first flight directors at NASA, each has a unique call sign that he or she uses for the team name during these activities. Specific details of each author are as follows:*

## Lead Author/Executive Editor:



**Robert C. Dempsey**, “Galileo Flight,” a former astronomer, has worked on the ISS Program since 1997. He served as a flight controller (Command and Data Handling and in Communications and Tracking) for 7 years before being selected as a flight director in 2005. Dr. Dempsey holds BS degrees in astronomy and physics from the University of Michigan (1984), as well as an MS and a PhD in physics from the University of Toledo (1986 and 1991, respectively).

## Contributing Authors:



**Dina E. Contella**, “Steel Flight,” has worked on the ISS Program since 1995, serving as a Space Shuttle and ISS flight controller (Extravehicular Activity) and astronaut instructor prior to being selected as a flight director in 2009. Ms. Contella holds a BS in aerospace engineering from Texas A&M University (1992).



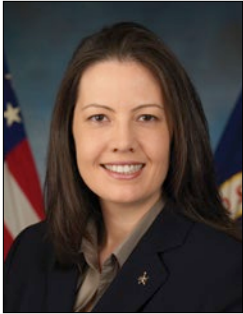
**David H. Korth**, “Odyssey Flight,” has worked on the ISS Program since 1990. He served as a flight controller (Planning) for 14 years before being selected as a flight director in 2007. Mr. Korth holds a BS in aerospace engineering from the Texas A&M University (1990) and is currently working on an MS in statistics from the University of Houston – Clear Lake (2017).



**Michael L. Lammers**, “Saturn Flight,” has been involved in ISS operations since 1996. He worked as a crew trainer before becoming a flight controller (Motion Control) in 2001. After managing the Communications and Tracking group, he was selected as a flight director in 2008. Mr. Lammers holds a BS in aerospace engineering from Iowa State University (1996) and an MS from the University of Houston (2004).



**Courtenay R. McMillan**, “Tranquility Flight,” has worked on the ISS Program since 1996, initially as a flight controller in the Motion Control Systems group. After a stint with the ISS Program’s Moscow Technical Liaison Office, she returned to the operations world to serve as lead for the Avionics Systems Integration group and technical assistant for the robotics and extravehicular activity division before being selected as a flight director in 2007. Ms. McMillan holds a BS in aerospace engineering from Pennsylvania State University (1992).



**Emily Nelson**, “Peridot Flight,” has worked on the ISS Program since 1998, serving as a flight controller (Thermal Control Systems) and as station duty officer before being selected as a flight director in 2007. Ms. Nelson holds a BS in mechanical engineering from the University of Texas (1998).



**Royce J. Renfrew**, “Tungsten Flight,” has worked in the ISS Program since 1997, originally as a robotics instructor in the Mechanical and Robotics Systems group, then in the Robotics Operations group in 2001. After serving as the Onboard Data Interfaces and Network (ODIN) group lead, he was selected to the flight director class of 2008. Mr. Renfrew holds a BS in computer science from Trinity University (1995). He also earned a BA in history, as well as secondary teaching certificates from Trinity University (1987).



**Brian T. Smith**, “Liberty Flight,” began working in flight control in 1998 on the Interim Control Module (which never flew) before becoming a flight controller in the Communications and Tracking group. He was selected as a flight director in 2005. Mr. Smith holds a BS in electrical engineering from Villanova University (1993), an MS in electrical engineering from the University of Pennsylvania (1996), and an MS in aerospace engineering from the University of Houston (2004).



**Scott A. Stover**, “Keystone Flight,” has worked on the ISS Program since 2000, serving as a flight controller (Electrical Power Systems) for 9 years before becoming group manager in 2008. He was selected for the flight director class of 2009. Mr. Stover received a BS in aerospace engineering from the Pennsylvania State University (2000) and an MS in space architecture from the University of Houston (2004).



**Edward A. Van Cise**, “Carbon Flight,” has worked on the ISS Program since 1998, serving as a flight controller (Operations Support Officer, Telemetry Information Transfer and Attitude Navigation) for 8 years and group lead (ISS Mechanisms & Maintenance Training group) for 2 years before being selected as a flight director in 2009. Mr. Van Cise received a BS in aerospace engineering from the University of Michigan (2000).

# Index

*Note: All terms are listed only at spelled-out version. See page 380 for list of acronyms and abbreviations.*

## A

abandoning ship. *See* decreding the ISS  
accumulators, fluid loop pressure management, 197, 199–201  
Active Thermal Control Systems (ATCSs)  
  External Thermal Control Systems (ETCSs), 192, 194, 197–204  
  Internal Thermal Control Systems (ITCSs), 205–207  
Advanced Recycle Filter Tank Assembly (ARFTA), 343  
Advanced Resistive Exercise Device, 13  
aerodynamic drag force impacting MCS, 128, 129  
air conditioning, 340. *See also* Thermal Control Systems (TCSs)  
Aircraft Operations Division, 32  
air leaks, troubleshooting and fixing, 271–272, 349. *See also* depressurization  
airlocks  
  air leaks into, 271  
  distance from P6 solar array, 321  
  EVA use of, 296–301  
  Joint Airlock (Quest), 49–50, 272, 283, 296–297, 298, 299  
  and spacesuits, 283  
  umbilical, 297, 300  
air tank deliveries, 335  
alarm tones from ATUs, 229  
alternating current (AC) vs. direct current (DC), 157–158  
ammonia-based thermal transfer system  
  Ammonia Tank Assembly (ATA), 201  
  challenges for Node 3 relocation and Cupola installation, 71, 72–75, 76–77, 79, 84  
  detection system for ammonia, 336  
  function in Thermal Control System (TCS), 197, 202  
  hydraulically locking, 373  
  InterFace Heat eXchanger (IFHX)  
    breaching, 174–175, 184, 217, 347, 350  
    leak simulation, 178  
  major failure of Pump Module, handling of, 354–377  
  risk of bringing in from EVA, 205, 302–303, 365  
  standard procedures for changes and repairs, 69  
  TCCS's limited capability to remove, 338  
  and water loop system, 357  
Ammonia Tank Assembly (ATA), 200, 201  
Anderson, Clay, 309  
Androgynous Peripheral Attachment System (APAS), 46, 47

anodized coatings to reflect heat, 195  
Apollo 1 fire, xii  
*Apollo 13* (film), x  
Apollo Program, spacewalks, 281  
array erosion, solar arrays, 170  
Assembly Complete configuration of ISS, 36  
Assembly Contingency Subsystem. *See* S-band communication system  
assembly of ISS. *See also* ExtraVehicular Activities (EVAs); making of a mission and availability of thermal control, 197–198, 201  
  Canadarm2's role in, 251–252  
  C&DH System, 106–107  
  centerline camera system for aligning components, 44  
  Columbia accident's impact on, 78  
  complexities of multiple EVAs for, 303  
  Control Moment Gyroscopes (CMGs), 121  
  Cupola, 63, 79  
  flight missions, xx–xxi  
  importance of EVAs to, 281  
  MCS, 135  
  mission designation system for, xix  
  need for human manual effort in, 291–292  
  Node 3, 63  
  pressurized modules, 38–41  
  sequence of assembly, xvii–xxiii  
  solar arrays, xix, xxi, 157, 164–165  
  stages in, xix  
  TCS, 194  
astronauts. *See* crew  
Atlantis, Space Shuttle, 75, 253  
atmosphere control, supply and revitalization.  
  *See also* depressurization  
  ammonia breach of IFHX, 174–175, 184, 217, 347, 350  
  atmospheric pressure in ISS habitat, 37, 336, 346–347  
  Common Cabin Air Assembly (CCAA), 337, 339, 340, 343  
  humidity levels, 199, 213–215, 337  
  monitoring contaminants, 336  
  Toxic Atmosphere (ATM), 217, 347  
  workings of, 334, 335–339  
Atmosphere Revitalization Rack, 338  
attitude control  
  auto handover process, 183  
  calculating attitude, 123–124  
  Control Moment Gyroscopes (CMGs), 128, 129–131, 132  
  with Control Moment Gyroscopes (CMGs), 128  
  overview, xxiv, 127–128  
  Russian Service Module, 120, 121  
  thrusters' function in, 129, 131, 133–134  
attitude hold controllers, 133  
attitude rate, 132  
audio baseband communication, 228–229

Audio Terminal Units (ATUs), 228–229  
auto handover process, 183, 185  
Automated Transfer Vehicle (ATV), ix, xvi, xviii, 46, 133, 235–236, 244  
avionics racks, 54, 57. *See also* Command and Data Handling (C&DH) System  
awards and prizes, ix  
Aziz, Sarmad, 329

## B

backpack, nitrogen-propelled. *See* SAFER backpack unit  
Backup state, MDM, 100  
Baikonur, Kazakhstan, 20  
Baitland, Lawrence, 376  
Barratt, Michael, 20, 33  
Baseband Communication System, 228–231  
Baseband Signal Processor, 223  
batteries  
  discharging, 161–162  
  monitoring during EVAs, 302  
  primary power system, 165  
  for solar energy collection, 157, 165  
  thermal control process, 199  
Battery Charge/Discharge Units (BCDUs), 165, 166  
Behnken, Bob, 75, 76, 78  
berthing/unberthing operations  
  CBCS, 45, 271  
  CBM, 39–41, 44, 45, 259, 261  
  coordination and process, 243–244, 245  
  port for berthing, 239  
  robotic systems' role, 239–240, 242  
beta angle ( $\beta$ ) for ISS noon vector and sun vector, 124, 125, 161–162, 168, 171  
Beta Gimbal Assemblies (BGAs), 111, 125, 163, 169–170  
biasing of solar array position, 171  
bidirectional UHF communication system, 227–228, 287–288  
Bigelow Expandable Activity Module, xviii, 259  
Black orbital debris risk level, 146  
Boeing Company, xxvii, 62, 246  
Bolinger, Allison, 369, 371, 376  
Boom A, Canadarm2, 254  
Boom B, Canadarm2, 254  
Bowen, Steve, 226  
Bowersox, Ken, 274  
breathing environment, EMU, 283, 285  
Brewer, Kyle, 88  
Buchilin, Alexei, 26  
Burbank, Dan, 28, 114, 115, 152–153, 295, 335  
bus controller (BC), 100  
Byerly, Joe, 369  
bypass line and valves, ATCS, 197, 202



## C

- call signs for control centers, xiii
- Canadian robotic arm (Canadarm).
  - See Space Station Remote Manipulator System (SSRMS)
- Canadian Space Agency (CSA), xiv, xxviii, 251, 259, 260–262
- capsule communicator (CAPCOM), 175, 178
- capture operations for visiting vehicles
  - crew's role in, 239–240, 241–243, 260–261
  - Cygnus (Orbital ATK), 237
  - Dragon (SpaceX), 243, 245
  - graphics overlay for capture operations, 243
  - H-II Transfer Vehicle (HTV), 258, 260–261
  - SSRMS's role in, 239, 254
- Carbon Dioxide Monitor (CDM), 336
- Carbon Dioxide Removal Assembly (CDRA), 275, 336–338, 346
- care packages for crew, 243
- cargo delivery and loading, xviii. *See also* visiting vehicles
- cargo teams, role of, 240
- Cargo Transport Carrier, 256
- Cassidy, Chris, 244, 290, 299
- Caution and Warning (C&W) system, xxiv, 104–105
- Centerline Berthing Camera System (CBCS), 44, 45, 271
- Central Computer (Russia), 121–122
- Chamitoff, Greg, 56
- Chang-Diaz, Franklin, 263
- change, managing in mission planning, 62
- chemical/toxic spill, 347
- Chief Training Officer (CTO), 179
- Chip Measurement System (CMS), 187, 336, 347
- closeout panels, 58–59
- CMG/Thruster Assist control mode, 134
- code life cycle, and handling change, 111–112
- Colbert, Stephen, 73
- “cold cross-tie,” power channels, 160
- coldplate system, 204, 207
- Collier Trophy 2009, ix
- Columbia Space Shuttle accident, 78, 211, 246, 311, 322
- Columbus module (ESA)
  - ammonia leak risk during Pump Module change out (2013), 369, 376–377
  - closeout panels in, 58
  - cooling valve issue on STS-130/ISS-20A (2010), 82
  - failure during STS-130/ISS-20A (2010), 84
  - need for Node 2 installation prior to delivery, 307
  - overview, xvii
  - shifting plans for delivery (2008), 314, 330
- Command and Control System (CCS), USOS
  - as global timekeeper for ISS, 100–101
  - and MDM upgrades, 99
  - overview, 93, 94
  - and software upgrades, 112
  - transition from Node software to, 106–107
  - upgrade transition, 117
- Command and Data Handling (C&DH) System, 92–107
  - assembly of, 106–107
  - Caution and Warning (C&W) system, xxiv, 104–105
  - Electrical Power System (EPS), 158–159
  - Motion Control System (MCS), 121–122
  - Multiplexer/DeMultiplexers (MDMs), 97–101. *See also individual MDMs by name*
  - overview, xxiv, 93–97
  - Portable Computer System (PCS), 93, 101–103, 111, 112–113, 216
  - Thermal Control System (TCS), 193
  - User Application Software, 105–106
- Command & Control Multiplexer/DeMultiplexers (C&C MDMs)
  - failures during SSRMS installation, 262
  - in-flight maintenance, 273
  - Motion Control System (MCS) role, 121–122
  - and software upgrades, 113
  - styles, 98–99
  - summary, 95–97
  - timekeeping for, 100–101
  - transition of software during assembly, 106–107
- Command & Data Handling Position (ODIN), xxv
  - commanders, designation for, xix
- Commercial Crew Program, xix, 17, 21, 246
- commercial off-the-shelf (COTS) equipment, 158
- Commercial Resupply Services (CRS), 114, 245–246. *See also* Cygnus (Orbital ATK) cargo vehicle; Dragon (SpaceX) cargo vehicle
- Common Berthing Mechanism (CBM), 39–41, 44, 45, 259, 261
- Common Cabin Air Assembly (CCAA), 337, 339, 340, 343
- communication
  - EMU equipment for, 287–288
  - overview, xxiv
  - TDRS scheduling challenges, 13
  - training for, 176, 177–179
- Communication and Tracking (C&T) system, 222–231
  - baseband communication systems, 228–231
  - linking with Command and Control System (CCS), 93
  - RF links, 223–228. *See also* RF (radio frequency) links
- Communications and Tracking Position (CATO), xxv, 93
- Communications Radio Frequency Onboard Network Utilization Specialist (CRONUS) position, 93
- Compound Specific Analyzer-Combustion Products (CSA-CP), 336, 337, 346, 348
- computer network, 92–97
- computer systems. *See* Command and Data Handling (C&DH) System
- condensate, 340–341
- condensation, controlling, 194–195
- Condensing Heat Exchanger (HX), 340
- conduction method for removing heat, 193
- conference calls on ISS, 28, 229
- configuration management, planning the ISS, 11–13
- conjunction, ISS and debris orbits, 142
- consoles in Flight Control Room (FCR)
  - daily log checking, 23–24
  - functions of, xxiv
  - training for console management, 177
- Constellation Program, 89
- consumables, managing for increment, 3
- Contaminant Control Cartridge (CCC), EMU, 285, 287
- Contella, Dina, 31, 36, 311, 329, 369, 371, 376, 377
- Contingency Water Container (CWC), 341–342, 343, 344
- control centers, worldwide locations, xxviii
- controllers. *See* Flight Control Team (FCT)
- Control Moment Gyroscopes (CMGs)
  - arrival on orbit, 135
  - assembly of, 121
  - attitude control with, 128, 129–131, 132
  - in Debris Avoidance Maneuvers (DAMs), 148
  - failures, 135–136
  - momentum management, 132–133
  - in robotic arm, 120, 132
- convection, 193, 345
- converter units, direct current (DDCUs), 165–166
- core completion phase of ISS, xv
- Corrective Maintenance, 269
- Cougar, Tamara, 329
- Creamer, T. J., 27
- crew. *See also* environmental control; *specific crew members by name*
  - assigning to increment, 4
  - C&C MDM rebuild, 273
  - Commercial Crew Program, xix, 17, 21, 246
  - core systems for crew support, xxiv
  - Daily Execute Package, 8, 13
  - decreding, planning for, 210–219
  - EVA preparation duties, 369–370, 372–373. *See also* Extravehicular Activities (EVAs)
  - exercise preferences, accommodating, 13
  - flexible activities for, 16
  - Houston and Canadian Ground Control coordination case study, 260–262
  - importance of phone call capability for, 226
  - increased efficiency with time on orbit, 15
  - increment operations, 20–33
  - initial capacity, xv
  - jumper installation duty, 161
  - new transport vehicles, 246
  - Nodule 3 relocation time management, 67

as on-board eyes and ears for FCT, 29, 216–217

personnel origin mix, xix

physical differences affecting choreography of EVA, 302

preparation for in-flight maintenance (IFM), 269

psychological support for, 3–4, 24, 27–28, 29

public relations activities, 82, 86

return to Earth activities, 32

Robotic Workstation (RWS), 258

role in robotic arm troubleshooting during installation, 262

safety issues for EVAs, 302, 318–320, 321

schedule management, 3–4, 9, 14–16

Soyuz Spacecraft transport of, 235

spacesuit care and use. *See* Extravehicular Mobility Unit (EMU)

standard complement on ISS, 20–21

in STS-120/ISS-10A mission, 309

transport to and from ISS, 20–21

visiting vehicle coordination role, 239–240, 241–243, 260–261

worksite preparation time, allowing for, 15

Crew Contamination Protection Kit (CCPK), 347

Crew Dragon (SpaceX), 246

Crewlock portion of Joint Airlock, 49–50, 296–297, 298, 299

crew support racks, 54

crisis simulations, 174–188

communications, 178–179

debrief, 187–188

emergency simulation, 182–187

failure scenarios in simulator, 179–182

purpose for training, 188

real-world ammonia leak crisis, 174–175

training process, 175–178

value of simulations, 175

CSA Space Operations Support Center, St. Hubert, Quebec, xxix

CST-100 Starliner, 246

Cuff Checklist, EMU, 288

Cupola

installation of, 37, 63, 79

opening of shutters on, 86, 87

relocation of, 64, 69, 71, 73, 83, 84, 85

Robotic Workstation (RWS) in, 258

structure and function of, 51

visiting vehicle role, 242

current, voltage, and mass, EPS, 157–158

Current Stage Requirements Document, 26–27

cyclogram script for Debris Avoidance Maneuvers (DAMs), 148

Cygnus cargo vehicle (Orbital ATK)

ammonia pump change-out impact, 355, 356, 358, 360, 361, 364, 366, 377

capture and berthing operation, 237, 242, 243

crew monitoring of launch, 234

loss of, 289

preparation for, 237–245

and timing in visiting vehicle operations, 244

cylindrical pressurized habitat modules, 37, 54

## D

daily console log checking, 23–24

Daily Execute Package, 5, 7–9, 13

Daily Planning Conference (DPC), 22–23, 24

Daily Summary, 13, 22–23

data transmission

MDMs, 99–100

S-band system's role in, 224–225

day in the life (of Flight Operations)

crisis simulations, 174–188

debris avoidance, 140–153

decreasing the ISS, 210–219

increment crew operations, 20–33

in-flight maintenance, 268–277

major anomaly, handling, 354–377

making of a mission, 62–89

software update and handling change, 110–116

spacewalks profile (STS-120/ISS-10A), 306–331

visiting vehicles, 234–246

Day of Execution, 9

DC-to-AC inverters, 158

DC-to-DC Converter Units (DDCUs), 158, 161, 165–166

debris avoidance, 140–153

conjunctions and relative velocities, 141

danger from orbital debris, 46–47

evaluating risk of collision, 145–147

growing problem of orbital debris, 151–153

maneuvers to avoid debris, 148–151

MMOD risk, 48, 283, 286, 301

nature of threat, 140–141

protection methods, 46–49, 53, 141–143

screening of debris, 145

tracking of debris, 143–144, 146–147

Debris Avoidance Maneuver (DAM), 145–151

decompression sickness (DCS), 285, 298–300

decreasing the ISS, 210–219

emergency response, 217–218

framing the discussion, 211–212

history of concept, 211

recrewing, 218

system changes, 213–216

training, 218

Degraded Joint OperationS (DJOPS), 264

delta-V (orbital velocity), 149

Dempsey, Robert, 84, 88

demultiplexing, defined, 97

depressurization

preparing for, 47–48, 143

prior to EVA, 298–299

responding to, 213, 217, 346–347, 348

desaturation, Control Moment Gyroscope (CMG) system, 131

desaturation thruster firings, 134

Dettwiler, MacDonald, 264

De Winne, Frank, 20

diagnostic equipment for in-flight maintenance (IFM), 270

Diagnostic Maintenance, 269

Direct Current Switch Unit (DCSU), 163, 166

Direct-Current-to-Direct-Current Converter Units (DDCUs), 158, 161, 165–166

direct current (DC) vs. alternating current (AC), 157–158

directed position mode for rotating solar arrays, 170

discipline lead, role and responsibilities, 63

Discovery, Space Shuttle. *See* STS-120/ISS-10A

Display and Control Module, EMU, 288

distributed vs. non-distributed electrical system, 157

docking systems

coordinating with solar arrays, 157

ground control for undocking, 213, 244

new commercial cargo vehicles, 242, 246

Progress supply vehicles, 46, 235

ship-to-ship communication, 228

Soyuz spacecraft, 31, 46, 235

Space Shuttle, 39, 41, 46, 235

structural, 39–41, 46

domains and redundancy, EPS, 159–160

Draeger tube, 303

Dragon (SpaceX) cargo vehicle

ammonia pump failure impact on schedule for, 355

capture and berthing, 242, 243, 245

cargo delivery and loading, 240–241

crew training, 240

day of arrival, 241–245

flight controller training, 238–239

Flight Control Team perspective, 241

loss of, 289

overview, 236

preparation for, 237–245

scheduling, 237–238

SpaceX Dragon D1, 114

Dream Chaser cargo vehicle, 245, 246

drink bag, EMU, 289, 290

dry vs. wet cargo, 235

Dyer, Jason, 259

## E

Early Communication System, 106

Early External TCS (EETCS), 198, 199, 201, 203, 205

Earth-facing science window, 51

effectors

C&DH system, 94

USOS Motion Control System, 129–130

Electrical Power System (EPS), 156–171. *See also* batteries; solar arrays

design decisions, 157–159

domains and redundancy, 159–160

feedthroughs for power in habitat modules, 37–38

heat transfer role, 200

jumper operations, 161, 215–216

overview, xxiv, 159–163

planning, energy balance, and load sheds, 161–162

power channels, 159, 160, 163

primary power system, 163–165

- redundancy, 159–160
- secondary power system, 165–171
- shock challenge when repairing solar array, 318–320
- SPARTAN flight controllers' planning role, 161, 162, 171, 356, 358
  - and Thermal Control System (TCS), 193, 204
- Electrical Power Systems Position (PHALCON), xxv
- electrolysis to produce oxygen, 335
- Ellington Field, 32
- emergency equipment, 345–347
- emergency response
  - crisis simulations, 182–187
  - decrewing the ISS, 217–218
  - environmental control, 348–350
  - fire, 217–218, 270, 336, 345, 346, 348
  - Rapid Depress, 47–48, 143, 213, 217, 346–347, 348
  - scenario exercise planning, 21
  - Toxic Atmosphere (ATM), 174–175, 178, 184, 217, 336, 347, 350
- Endeavour, Space Shuttle, ix, 37, 80, 235, 252
- energy balance, maintaining for EPS, 162
- Engineering team, FCT's coordination with, x engineer training as common for flight controllers, 175
- Enhanced MDMs, 98–99
- Enhanced Processor and Integrated Communication (EPIC) controller card, 97, 114–115
- Environmental and Thermal Operating Systems (ETHOS)
  - atmospheric humidity management after decrewing, 213
  - operator level of certification for flight controller, 177
  - responsibilities of, 334, 335, 336, 340, 341, 344–350
  - Toxic Atmosphere scenario, 174
- Environmental Control and Life Support System (ECLSS), 334–350
  - atmosphere control, 335–339. *See also* atmosphere control
  - emergency equipment, 345–347
  - emergency response, 348–350
  - planning for STS-130/ISS-20A, 64, 70–71
  - Regenerative ECLSS, 213–215
  - STS-130/ISS-20A issues, 85
  - temperature and humidity control, 340. *See also* Thermal Control Systems (TCSs)
  - water recovery and management, 340–345
- Environmental Control and Life Support Systems Position (ECLSS), xxv
- Equipment Lock, 297
- European Attached Pressurized Module. *See* Columbus module
- European Robotic Arm, 250
- European Space Agency (ESA). *See also* Columbus module
  - Automated Transfer Vehicle (ATV), ix, xvi, xviii, 46, 133, 235–236, 244
  - importance of Node 2 for, 307
  - role in ISS Program, xiv
- EVA 1, STS-120/ISS-10A mission, Node 2 temporary installation, 310, 312–313
- EVA 2, STS-120/ISS-10A mission, SARJ inspection during, 311–312, 313–314
- EVA 3, STS-120/ISS-10A mission, P6 segment release, 310, 314
- EVA 4, STS-120/ISS-10A mission, focus changes in, 310–311, 314, 316
- EVA 5, STS-120/ISS-10A mission, planned Node 2 preparation for Columbus module, 310
- EVA 23, water-in-helmet incident, 290
- EVA 24, Pump Module change-out, 360, 369–372
- EVA 25, Pump Module change-out, 360, 372–376
- EV hatch, 49
- execute planning by Flight Control Team, 5, 7–11
- Execute Planning Groundrules and Constraints (Gr&C), 5
- execution of a mission (“fly”), 63, 80–87
- exercise sessions, scheduling challenges, 13, 24
- Expedite the Processing of Experiments to the Space Station (ExPRESS), xxiii, 46, 57
- Expedition 1, US Laboratory, 54
- Expedition 6, in-flight maintenance (IFM), 274
- Expedition 7, exercising during, 25
- Expedition 8, detecting leaks in windows, 52
- Expedition 16, closeout panel, 58
- Expedition 17, rack installation, 56
- Expedition 18, robotics, 258
- Expedition 19/20, hanging the plaque, 33
- Expedition 22, relocating Cupola, 83
- Expedition 24/25 (STS-120/ISS-10A), 51, 322–323
- Expedition 26, robotics, 257
- Expedition 27, Soyuz photo of Space Shuttle docked to ISS, 235
- Expedition 28, preparing to abandon ship, 214–215
- Expedition 29
  - payload rack, 58
  - preparing to abandon ship, 214–215
- Expedition 30
  - free time during, 28
  - software upgrade story, 114–115
- Expedition 31
  - graphics overlay usage, 243
  - software upgrade story, 114–115
  - video system management, 231
- Expedition 32, EMU equipment, 296
- Expedition 34, exercising on COLBERT, 73
- Expedition 36, visiting vehicles, 244, 258
- Expedition 37, visiting vehicles, 244
- Expedition 38
  - Pump Module change out, 354, 361–377
  - visiting vehicles, 242
- Expedition 39, visiting vehicles, 242
- Expedition 41
  - ammonia leak warning, 184
  - visiting vehicles, 242
- Expedition 42, ammonia leak warning, 184
- Expedition 43, return to Earth landing, 31
- Expedition 45
  - free time during, 28
  - visiting vehicles, 234
- Expedition 46
  - Mobile Transporter repair activity, 30
  - Soyuz crew docking, 31
- Expedition 47
  - Cygnus capture, 237, 259
  - Soyuz crew docking, 31
- Expedition 49, pre-increment planning, 21
- expedition designations to ISS, xix
- Exposed Pallet (EP), 46
- External Berthing Camera System (EBCS), 45–46
- external DC-to-DC Converter Units (DDCUs), 166
- External Operations (EVA) mode, 106. *See also* ExtraVehicular Activities
- External Stowage Platforms (ESPs), xxiii
- External Television Camera Group, 230
- External Thermal Control Systems (ETCSs), 197–204. *See also* ammonia-based thermal transfer system
  - components and flow paths, 200
  - heat exchangers, 201–202. *See also* InterFace Heat eXchangers (IFHXs)
  - loads and radiators, 202–204
  - overview, 194
  - pumps and accumulators, 199–201
  - radiators, 157, 159, 160, 161, 202–204
  - temperature and humidity control, 199, 334, 340
- external torques, managing, 132–133
- External Wireless Instrumentation System, 42
- ExtraVehicular Activities (EVAs), 280–303. *See also* spacewalk in detail
  - ammonia leak (outside) solution, 205
  - assembly of ISS, xv, xix
  - communication system for, 227–228
  - Control Moment Gyroscope (CMG) use in robotic arm, 120
  - Cupola relocation, 85
  - EVA console at MCC, 269, 302
  - fatigue from, 301, 302
  - go-ahead tasks for, 292
  - historical perspective, 281–283
  - impact on daily routine, 30–31
  - importance of robotic arm for, 250
  - new Joint Airlock delivery, 272
  - Node 3 change in location, 66–67, 68–69, 72–75
  - physical dangers of, 280
  - planning and training for, 68–69, 290–292
  - PMA-3 relocation, 86
  - preparations and airlock, 296–301
  - Pump Module change-out (2013), 360, 364–365, 366–376
  - repair of robotic arm, 263–264
  - risk management, 301–303
  - testing and training, 77, 293–295
  - timelines for (STS-130/ISS-20A (2010)), 82

tools, 295–296, 325, 330  
 unsticking of hardware, 274  
 value for further space exploration, 303  
 Extravehicular Mobility Unit (EMU), 283–289,  
 290, 291  
 components and operation of, 283–289  
 failures during STS-120/ISS-10A, 323–324  
 fitting system, 288–289  
 gloves, 283, 286, 289, 371  
 life support in, 283, 285  
 managing risks of using, 302  
 monitoring from MCC, 302  
 preparing for P6 4B solar array repair, 320  
 Pump Module change out mission, 360, 366,  
 371, 372  
 storage of, 301  
 water-in-helmet incident, 289, 290, 291,  
 355, 364, 365, 366  
 Eyharts, Leopold, 58

## F

Failure Detection, Isolation, and Recovery  
 software, 105  
 failure scenarios in simulator, 179–182,  
 180–183  
 “false ammonia event,” 175  
 Fan/Pump/Separator (FPS), EMU, 290, 291  
 “feathering” of solar arrays, 161  
 feedthroughs for power, data, gas, liquids in  
 habitat modules, 37–38  
 Fengyun-1C weather satellite, destruction of,  
 151, 152  
 Fincke, Michael, 258, 289  
 fire  
 CSA-CP’s role in detecting, 336  
 decrewing the ISS, 217–218  
 ISS Post-Fire Cleanup Kit, 270  
 responding to, 345, 346, 348  
 flexible activities, use of, 16  
 “flexures,” defined, 169  
 flight control, history of, xxiii  
 Flight Control Center Houston, integration  
 responsibility for execute planning, 14  
 Flight Controller Part Task Trainer simulator,  
 175, 176  
 flight controllers. *See also* Flight Control Team  
 (FCT)  
 assignment to an increment, 21  
 certifications, xxvii–xxviii, 177  
 coordination of shifts, 23  
 engineer training as common for, 175  
 qualifications and training, xxvii–xxviii  
 SPARTAN planning role, 161, 162, 171,  
 356, 358  
 visiting vehicle training, 238–239  
 Flight Control Room (FCR), xxiv, 23–24, 177  
 Flight Control Team (FCT). *See also* flight  
 controllers; flight director  
 attitude control coordination, 134–135  
 camaraderie for every increment, 33

communication methods among operators,  
 xxvi–xxvii  
 coolness under emergency scenario, 175  
 coordination of schedule and task  
 completion with crew, 16–17  
 crew as on-board eyes and ears for, 29,  
 216–217  
 EVA role, 302  
 evolution of schedule and daily operations,  
 xxvi  
 foundations of, xii–xiii, 306  
 hierarchy of, xxiii  
 holiday celebrations with crew, 27  
 increment crew operations, 21–27  
 introduction, ix–xiii  
 major anomaly handling, 354–377  
 making adjustments for decrewed ISS,  
 217–218  
 mission role, 62–63  
 naming conventions, xxx  
 planning process, 4–7  
 power planning, 161  
 Pump Module repair Team 4, 359–376  
 robotics operations, 258–260  
 shift management, 25, 63–64  
 simulation training, 174–188  
 software upgrade role, 111–115  
 special teams for complex operations, 30  
 STS-120/ISS-10A Team 4, 314–318, 324,  
 329, 330–331  
 STS-130/ISS-20A mission execution, 80,  
 82–89  
 visiting vehicle operations, 244  
 Flight Crew Operations, merging with Mission  
 Operations, xi  
 flight director “Flight”  
 assignment of, 21, 63–64  
 crew and FCT coordination role, 28  
 as crisis leader, ix–x  
 daily console log checking, 23–24  
 daily meeting planning activities, 27  
 leadership role, xxiii  
 mission execution role, 80, 82, 85  
 mission-making role, 62  
 qualifications for, xxviii  
 role of, ix–x  
 selection of, 177  
 training role, 76, 182–183  
 Flight Director Position (FLIGHT), xxv  
 Flight Director’s Suite, 24  
 flight engineers, designation for, xix  
 flight-like units, for testing software upgrades,  
 111  
 Flight Operations, x–xi. *See also* day in the  
 life; Flight Control Team (FCT)  
 Flight Operations Directorate, xv, 251  
 Flight Readiness Reviews, 22  
 flight rules, xxiii–xxiv  
 flight-specific simulations, 177–180  
 flight surgeon conference with crew members,  
 28  
 FLIGHT voice loop, 178  
 Flow Control Valves (FCVs)

in Thermal Control System, 197, 199, 200,  
 203  
 troubleshooting 2013 failure, 358, 359  
 fluid loops, 188, 196, 206  
 Fluids Integrated Rack (FIR), 58  
 Fluid System Servicer, 270  
 Foale, Mike, 52, 65  
 food, psychological benefits of communal  
 eating, 29  
 foot restraints, EVA, 295–296  
 forced convection, 193  
 Foreign Object Debris, on P6 SARJ, 313–314.  
*See also* debris avoidance  
 Fossum, Mike, 58, 214–215  
 Foundations of Flight Control, xii–xiii, 306  
 4-Box computer architecture, MCS, 121  
 “four-box testing,” and software upgrades, 112  
 “franken hoses,” 75  
 Free Drift/Indicator control mode, 134, 239  
 Functional Cargo Block (FCB), xix, 135

## G

Garr, John, 88  
 Gas Pressure Regulating Valve (GPRV), 201  
 Gemini Program, spacewalks, 281  
 General Purpose Computers (GPCs) on Space  
 Shuttle, 97  
 Generic Groundrules, Requirements, and  
 Constraints (GGR&C), 3, 9  
 Gennady Padalka, 20  
 geosynchronous transfer orbit, 142  
 Gerst, Alexander, 242  
 Gerstenmaier, William, 22  
 Getzleman, Hal, 84  
 Global Positioning Satellite (GPS)  
 antenna array to access, 126  
 in attitude determination, 127  
 for ISS navigation, 93  
 Motion Control System’s use of, 120  
 Russian Segment receivers, 126  
 and ship-to-ship communication, 228  
 as timekeeper, 101  
 US Segment receivers, 125–126  
 gloves, spacesuit, 283, 286, 289, 324, 371  
 Goetter, Chris, 329  
 Graphical User Interface (GUI), PCS, 102–103  
 graphics overlay for capture operations, 243  
 grapple fixtures, SSRMS, 254–255, 256, 257  
 gravity gradient forces impacting Motion  
 Control System, 129  
 Green debris risk level, 145, 146  
 Ground-based Electro-Optical Deep Space  
 Surveillance system, 144  
 ground-based telescopes, debris tracking by,  
 144  
 ground control. *See* Flight Control Team (FCT)  
 ground determination of ISS location, 122–125  
 Ground Systems and Networks Position (GC),  
 xxv  
 Guidance, Navigation and Control Multiplexer/  
 DeMultiplexer (GNC MDM)  
 attitude control, 130

attitude determination, 127, 128  
and Beta Gimbal Assembly control of Solar  
Array Wings, 169  
desaturation request, 131  
function of, 93, 121–122  
GPS adjustments, 126, 127  
high-gain antenna, 224  
Gulfstream G3 aircraft for returning crews to  
USA, 32

## H

Haddon, Robert, 329  
Hadfield, Chris, 205  
Ham, Ken, 56  
handover training from crew to crew, 215, 218  
“hanging the plaque” duty, 32–33, 88, 89  
Hard Upper Torso, EMU, 297–298  
Hasbrook, Annette, 329  
Hassman, Derek, 329  
hatches  
air leak management role of, 349  
as feedthroughs, 38  
secondary structure components, 49–50  
hatch windows, 50  
heartbeat software, 105  
heater patches to control condensation, 194, 195  
heat exchangers. *See* InterFace Heat  
eXchangers (IFHXs)  
heat pipes, 166, 194  
heat rejection point. *See* radiators  
Heat Rejection Subsystem (HRS), 202, 203  
heat transfer. *See* Thermal Control Systems  
(TCSs)  
Hefflin, Milt, xi  
helmet cam video, EMU, 228  
helmet lights, EMU, 289  
Helms, Susan, 92  
hemispherical antenna, LDR mode, 225  
Herrington, John B., 228  
high-data-rate (HDR) mode, S-band system,  
224–225  
High Efficiency Particulate Air (HEPA) filters,  
340  
high-gain antenna (HGA), 224, 225  
high-level manifest, planning for the increment,  
3  
H-II Transfer Vehicle (HTV), Japan, 236,  
237–245  
cargo delivery and loading, 240–241  
coordination for HTV5 mission, 258,  
260–262  
crew training, 240  
day of arrival, 241–245  
flight controller training, 238–239  
overview, xviii  
scheduling, 237–238  
hobbies, pursuing on ISS, 27–28  
hockey stick tool to prevent electrocution, 320,  
321, 330  
holidays and time off for crew, 3–4, 27–28  
home control center, visiting vehicle missions,  
238–239, 241

Hopkins, Mike, 242, 280, 361, 373, 374–375  
Hoshide, Aki, 296, 371, 376  
“hot cross-tie,” power channels, 160  
Houston Support Group in Russia, xxvii  
HTV Berthing Camera System, 46  
humidity levels in ISS atmosphere, 199,  
213–215, 337  
humor, need for in ISS environment, 29  
Huntsville Control Center, xiii, xxvi, xxix, 294  
hypergolic propellant, 121  
hypervelocity impacts, 141. *See also* debris  
avoidance

## I

IBM T61 laptop as PCS, 101  
increment crew operations, 20–33. *See also*  
making of a mission  
complex operations, 30–31  
conferences, crew to ground, 28  
controllers and crew daily routine, 22–27  
ground preparations, 21–22  
increment defined, xix, 3  
planning of increment, 2–11, 26–27  
Red Line, chasing of in daily activities, 29  
return to Earth, 32–33  
time off for crew, 27–28  
Increment Definition and Requirements  
Document (IDRD), 3, 7  
Increment Overview, 5, 6  
Increment Requirements Definition Document,  
26–27  
in-flight maintenance (IFM), 268–277  
air leaks, 271–272  
Carbon Dioxide Removal Assembly  
(CDRA), 275  
Centerline Berthing Camera System  
(CBCS), 271  
Command & Control MDMs, 273  
EVA activity for, 280, 303  
methodology, 269  
mod kit, 277  
tools and diagnostic equipment, 270  
unsticking hardware, 273–274, 276  
inhibits to electrical voltage, for safety, 158  
input/output cards, Multiplexer/DeMultiplexer  
(MDM), 99  
insulation, Internal Thermal Control System  
(ITCS), 194, 195  
Integrated Truss System “the truss”  
attachment sites, 39, 43  
components color-coded by country, xvii  
Mobile Transporter parking, 257  
naming of segments, 43  
overall structure of, xv, 36–46  
Photo-Voltaic Modules (PVMs), 159  
Radiator Beam Truss Structure, 203, 204  
robotic arm’s role in assembling, 252  
Space Vision System (SVS) for connecting,  
45  
thermal control components, 198  
Integration for Visiting Vehicles Position (ISE),  
xxvi  
Intel 386 processor, 97  
InterFace Heat eXchangers (IFHXs)  
ammonia leak, 174–175, 184, 217, 347, 350  
and limits of TCCS, 338  
in Node 3 modification, 66  
and Pump Module failure, 357  
schematics, 196, 200  
structure and thermal process role, 201–202  
InterModular Ventilation (IMV), 213, 217, 339,  
340, 347  
Internal Audio Controllers (IACs), 178  
internal DC-to-DC Converter Units (DDCUs),  
166  
Internal Thermal Control Systems (ITCSs),  
194, 205–207, 216. *See also* InterFace Heat  
eXchangers (IFHXs)  
Internal Wireless Instrumentation System, 42  
International Docking Adapter extensions, 46  
International Execute Planning Team (IEPT),  
5–11  
international nature of ISS operations, naming  
conventions and language issue, xxx  
international partner presence. *See also*  
Canadian Space Agency (CSA);  
European Space Agency (ESA); Japan  
Aerospace Exploration Agency  
(JAXA); Russian partner agency  
Canada’s robotics contribution, 251  
DPC participation, 22  
at MCC-H, xxvii  
International Partners Liaison Position (RIO),  
xxv  
International Space Station (ISS). *See also*  
assembly of ISS  
Assembly Complete configuration, 36  
components by contributing country, xvii  
composite images, xvi  
historical overview, xiii–xv  
logistical complexities, 234  
modularity of, xxi–xxii  
with Node 3 and Cupola installed, 87  
orbit compared to space debris, 142  
planning of, 2–17  
radiator panels, 192  
size of, xviii  
solar arrays image, 156  
structural overview, xv–xvii  
technical names for components, xv, xvii  
internet  
access on ISS, 27  
live-streaming video from ISS to, 230  
Inventory Management System, rack location  
designations, 58  
iodinated water, 340  
Iridium 33 communications satellite, 141, 151,  
152  
isolation software, 105  
Isolation Valve, IFHX, 202  
ISS Flight Control Positions, xxv, xxx  
ISS Leak Kit, 270  
ISS Management Console, xxvii  
ISS mission designations. *See entries*  
*beginning with STS*

ISS Mission Management Team (IMMT), xxiii, 9, 24, 30, 369  
ISS Post-Fire Cleanup Kit, 270  
ISS Program Office, xxiii, xxvii  
ISS Research Integration Office, xv  
ISS Toolbox, 270

## J

Japan Aerospace Exploration Agency (JAXA), xiv, 307  
Japanese Airlock hatches, 49  
Japanese Experiment Module (JEM)  
  External Exposure Facility, xv, 46, 262  
  racks in, xxii, 55, 56  
  Remote Manipulator System Main Arm and Small Fine Arm, 250  
  windows in, 51  
Japanese H-II Transfer Vehicle. *See* H-II Transfer Vehicle (HTV)  
“job jar” activities, 27  
Joint Airlock (Quest), 49–50, 272, 283, 296–297, 298, 299  
Joint Operations, in visiting vehicle operations, 239, 241–243  
Joint Operations Panel (JOP), 21, 25–26, 32  
“joint sims,” 63  
Joint Space Operations Center (JSpOC), 145, 147, 148  
Joint Station Local Area Network (JSL), 216  
“Jules Verne” (ESA ATV), 244  
jumpers  
  crew installation of, 161  
  Launch-To-Activation (LTA), 68  
  role in Electrical Power System (EPS), 215–216  
  UOP Bypass Jumper, 216  
  for video connection problem, 271

## K

Ka-band communication system, 222  
Kelly, Scott, 28, 33  
Kharmats, Paul, 26  
Knight, Norman, 376  
Kononenko, Oleg, 28  
Kopra, Tim, 33  
Kornienko, Mikhail, 28  
Kosmos 2251 military communications satellite, 141, 151  
Kotov, Oleg, 27, 361, 369  
Kounotori (White Stork). *See* H-II Transfer Vehicle (HTV)  
Kowalczyk, Bill, 376  
Kraft, Christopher Jr., xi, xii, xxiii  
Kranz, Gene, xi, xii  
Krikalev, Sergei, 54  
Ku-band communication system, 97, 127, 216, 223, 224, 225–227  
Ku Communications Unit (inside ISS), 226  
Kuipers, Andre, 230, 231

## L

Laboratory (Destiny) module (USOS)  
  activating computers on, 107  
  and Control Moment Gyroscopes (CMGs), 121  
  development of, xv  
  Expedition 1 installation of, 54  
  ground construction of, 37  
  Robotic Workstation (RWS), 258  
  Thermal Control System elements, 195, 198, 205–206  
  and user-friendly naming of modules, xvii  
  window in, 51  
Lammers, Michael, 24, 26, 33  
Latching End Effector (LEE), 254–255, 260, 261, 263  
Launch-To-Activation (LTA) jumpers, 68  
L-band communication system (for GPS), 222  
Lee, Andrew, 33  
Lee, Mark, 282  
Lessons Learned reviews  
  making of a mission, 87–88  
  planning the ISS, 14–17  
  software update and handling change, 116  
  spacewalk (STS-120/ISS-10A), 330–331  
life support, xxiv, 70, 334–350. *See also*  
  Environmental Control and Life Support System  
  Life Support System Backpack, 299  
  Lindgren, Kjell, 23, 33, 242, 262  
Liquid Cooling and Ventilation Garment (LCVG), 287, 297, 299  
Lithium Hydroxide (LiOH) canisters, 336  
loads and radiators, ETCS, 202–204  
load sheds, controlling, 105  
Load Shed Table, 117  
Local Vertical, Local Horizontal (LVLH), 123, 124, 125  
locating the ISS. *See* Motion Control System (MCS)  
longeron shadowing, 170–171  
long-range planning (LRP) team, 7–8, 12–13  
Loop Crossover Assembly, 188, 206  
Lopez-Alegria, Michael E., 228  
loss of supply missions, dealing with  
  Cygnus, 289  
  multiple losses challenge (2014–2015), 234–235  
  Progress 44P, 210, 211, 214–215, 218–219  
lost items on ISS, 4  
low-data-rate (LDR) mode, S-band system, 224–225  
low-Earth orbit, forces impacting Motion Control System (MCS), 128–129. *See also* debris avoidance  
Lower Torso Assembly, EMU, 289, 297  
Low Temperature Loop (LTL), ITCS, 177–178, 206, 216, 340, 344–345  
Lu, Ed, 25

## M

Main Bus Switching Units (MBSUs), 160, 163, 167, 310  
maintenance activity category, 29  
major anomalies, handling, 354–377  
Major Constituent Analyzer (MCA), 336  
making of a mission, 62–89  
  execution of mission (fly phase), 63, 80–87  
  Lessons Learned review, 87–88  
  planning, 62, 63–75  
  training, 62–63, 75–79  
Malenchenko, Yuri, 309, 310  
manual berthing mechanism, 40  
manual free mode for rotating solar arrays, 170  
Manual Pressure Equalization Valves (MPEVs), 339  
Marshburn, Tom, 73  
Mass Storage Disk (MSD), 99  
Mast Camera, 256  
Mastracchio, Rick, 280, 300, 354, 361, 368, 369, 373  
Maximum Absorption Garment, 297  
McMillan, Courtenay, 33  
mechanical radars, debris tracking, 144  
Medical support position (BME), xxv  
Melroy, Pam, 309  
metabolic rate, monitoring during EVAs, 302  
microgravity  
  difficulty of maintaining fire, 193, 345  
  managing atmospheric mixing in, 336–337  
  Neutral Buoyancy Lab approximation of, 293  
  thruster use impact on, 132  
  Vomit Comet’s training in, 294  
Microgravity mode, 106  
MicroMeteoroid and Orbital Debris (MMOD), 48, 283, 286, 301  
microphone, EMU, 288  
Mighty Mouse software, 107  
Military Standard 1553 communication protocol, 99  
Millstone/Haystack radar complex used to track orbital debris, 143  
mini simulations, 175–176  
Mini-Workstation, EMU, 296, 298  
Minnie Mouse software mode, 107  
Mir space station, xiv–xv, 46  
mission cognizance, training for, 177  
Mission Control. *See* Flight Control Team (FCT)  
Mission Control Center CST-100, 246  
Mission Control Center – Dulles (MCC-D), xiii, xxviii  
Mission Control Center – Houston (MCC-H or Houston)  
  international partner presence, xxvii  
  overview, xiii  
  propulsion to higher orbit for debris avoidance, 148–149, 151  
  visiting vehicle mission role, 239, 241, 244

Mission Control Center – Moscow (MCC-M or Moscow)  
 overview, xiii  
 propulsion to higher orbit for debris avoidance, 148–149, 151  
 visiting vehicle mission role, 239  
 Mission Control Center – SpaceX (MCC-X), xiii  
 Mission Evaluation Room (MER), xxvii  
 Mission Operations, merging with Flight Crew Operations, xi  
 Mission Operations Support, xv  
 mission patch, x–xi  
 mission planning. *See* planning the ISS  
 Mobile remote servicer Base System (MBS), 37, 256–257  
 Mobile Servicing System (MSS), 258–264  
 crew operations and Robotic Workstation, 258  
 ground/crew coordination case study, 260–262  
 ground operations and FCT, 258–260  
 operational challenges and triumphs, 262–264  
 Mobile Transporter, 30, 37, 256–257, 308  
 Moderate Temperature Loop (MTL), ITCS, 177–178, 206, 216  
 Moderate Temperature Thermal Control System rack, 57  
 mode transitions, computer system support for, 106  
 momentum management, 132–133  
 Monthly Calendar Plan, 5, 15–16  
 Montreal Control Center, xiii, 259  
 Moscow Support Group at MCC-H, xxvii  
 Mostly Liquid Separator (MLS), 343  
 Motion Control Position (ADCO), xxv  
 Motion Control System (MCS), 120–136  
 assembly of, 135  
 attitude control, 93, 120–121, 128, 129–136  
 attitude determination, 127–128  
 computer system elements, 121–122  
 control modes, 134–135  
 ground determination of ISS location, 122–125  
 orbit determination of ISS location, 125–127, 135  
 rocket thruster control, 128–129  
 Russian Segment attitude control, 133–134  
 US Segment attitude control, 132–133  
 vectors, 122–125  
 Mularski, John, 376  
 Multi-Filtration Beds, 344  
 MultiLayer Insulation (MLI), 48, 311, 312  
 Multiplexer/DeMultiplexers (MDMs). *See also individual MDMs by name*  
 failure of, 84, 106, 262  
 function in computer system, 94, 95–101  
 simulation failure, 177  
 and software upgrades, 111  
 multiplexing, defined, 97

Multipurpose Laboratory Module (RSA), xxi, 250  
 Multi-Purpose Logistics Modules (MPLMs), xviii, 252, 271  
 Multipurpose Support Room, xxiv  
 Munich or Columbus Control Center, xiii, xxviii

## N

NASA, integration responsibility for ISS, xv  
 NASA Johnson Space Center, pre-increment planning, 5  
 NASA/Marshall Space Flight Center, xxviii  
 Nespoli, Paolo, 235, 309  
 Neutral Buoyancy Laboratory (NBL), 66, 77, 79, 293, 365, 366  
 Neutral Buoyancy Simulator, Huntsville, Alabama, 294  
 Next Worst Failure analysis, 361–362, 366  
 Nitrogen Introduction Assembly, 206  
 Nitrogen Tank Assembly (NTA), 200, 201  
 Node 1 (Unity)  
 CBCS wiring, 271  
 modification to accommodate Node 3, 64, 65–67  
 relocation of, xxi  
 Node 2 (Harmony)  
 delivery and temporary installation, 307, 310, 312–313  
 InterModular Ventilation (IMV), 339  
 in making of a mission, 64  
 preparing for Columbus module, 310  
 relocation of, xxi  
 Node 3 (Tranquility)  
 activation of, 84–85  
 assembly mission to attach, 63  
 change in planned location of, 64–66  
 and Cupola relocation, 83  
 on Endeavour, 80  
 EVA planning for, 66–67, 68–69, 72–75  
 remodeling activities around installation of, 70–73  
 in Space Shuttle, 37  
 Node Control System (NCS), 106–107  
 Node Multiplexer/DeMultiplexers (Node MDMs), 106  
 Noguchi, Soichi, 27  
 non-distributed vs. distributed electrical system, 157  
 Nyberg, Karen, 244, 258

## O

Obama, Barack  
 Constellation Program redirection, 89  
 linkup with ISS crew, 82, 86  
 Okuda, Mike, xi  
 Onboard Data Interfaces and Network (ODIN) team, 93, 106, 262  
 Onboard Short Term Plan (OSTP), 5, 9, 10–11  
 On-orbit Operations Summary (OOS), 5–9

on-the-job training, flight controller, 177  
 Operational state, MDM, 100  
 Operations Planning TIMeline Integration System (OPTIMIS), 10–11, 16–17  
 Operations Support Officer (OSO) team, 64, 66, 69, 84, 269  
 operations team, software upgrades, 111–116  
 operator level of certification for flight controller, 177  
 OPS PLAN team  
 execute planning, 7–8, 12–13  
 monthly calendar plan, 15–16  
 Planning Position, xxv  
 post-increment analysis, 17  
 orbital adjustments to accommodate visiting vehicle schedule, 237, 240  
 orbital altitude of ISS, 122–123  
 Orbital ATK Control Center (MCC-D), xxviii.  
*See also* Cygnus cargo vehicle  
 Orbital Conjunction Message (OCM), 146  
 orbital debris, density by altitude, 152. *See also* debris avoidance  
 orbital-raising maneuver to avoid debris. *See* Reboost mode  
 Orbital Replacement Units (ORUs), xxii–xxiii, 36, 223, 257, 273  
 orbit determination of ISS location, 125–127, 135  
 orbiter, defined, xiv  
 Orbiter Boom Sensor System (OBSS), 317, 320–322, 323, 327, 330  
 Orlan spacesuit, Russian, 281, 283, 289  
 oxygen. *See also* atmosphere control  
 supply to EMU, 285, 335  
 usage during EVAs, 302  
 Oxygen Generator Assembly (OGA), 82, 335, 339, 344, 345, 361

## P

P6 PhotoVoltaic Control Unit (PVCU) MDMs, 106  
 P6 solar arrays  
 location of, xvii  
 plans for movement of, 308–308, 310  
 P6 4B solar array repair (STS-120/ISS-10A), 314–330  
 airlock distance from, 321  
 boom sensor break risk, 321–323  
 bounciness of boom issue, 320–321  
 crafting repair materials on orbit, 318  
 cuff link solution, 318–319, 328  
 damage location challenge, 316–317  
 electric shock and sharp edges hazards, 318–320  
 EVA operation, 327–330  
 images of damage, 315, 317, 325  
 mysteries in damage, 317  
 planning for, 324–326  
 spacesuit failures, 323–324  
 time constraints for, 324

- Padalka, Gennady, 33
- Parazynski, Scott, 309, 310, 311, 313–314, 316, 320, 321, 322, 324–329
- Parmitano, Luca, 244, 290, 355
- Part Task Trainer simulator, 175, 176
- Passive Thermal Control Systems (PTCSs), 192, 194–195
- patch, mission, x–xi
- Patrick, Nick, 75, 78, 83, 84, 85
- Payload Multiplexer/DeMultiplexers (Payload MDMs), 98–99, 273
- payload operations director, xxvi
- Payload Operations Integration Control Center, Huntsville Alabama, xxvi, xxix
- Payload Orbital Replacement Unit Accommodation (POA), 256, 257
- payload racks, 54, 57, 58
- Peake, Tim, 33
- Permanent Multipurpose Module (PMM), xviii, 38, 50, 72–73
- Perrin, Phillippe, 263
- Pettit, Donald, 114–115, 258, 274
- phased array radars, debris tracking, 144
- phasing portion of visiting vehicle mission, 241
- phone calls, crews' space-to-ground, 28
- Photo-Voltaic Modules (PVMs), 159, 163, 164, 168–169
- PhotoVoltaic Radiator (PVR), 202–203
- PhotoVoltaic Thermal Control System (PVTCS), 198, 199, 201, 203, 205
- pin kits for resolving electrical failures, 161
- Pistol Grip Tool, 296
- “pizza box” around ISS for close debris encounters, 145
- Planning Product Change Request (PPCR), 11–12
- planning the ISS, 2–17
  - components of mission plan, xxiii
  - configuration management, 11–13
  - increment planning, 5–11
  - lessons learned, 14–17
  - long-range planning, 2–5
  - scheduling changes, 13–14
- Plasma Contactor Units, 320
- PLug-in-plan and UTilization Officer (PLUTO), xxv, 93, 216
- plume impingement, 170
- Pointing position of the ISS Position (Pointing), xxv
- pointing systems, 168–170
  - Beta Gimbal Assemblies, 111, 125, 163, 169–170
  - Solar Alpha Rotary Joints, 168–169. *See also* Solar Alpha Rotary Joints (SARJs)
- Portable Breathing Apparatus (PBA), 346, 347, 350
- Portable Computer System (PCS), 93, 101–103, 111, 112–113, 216
- Portable Fire Extinguisher (PFE), 346, 348
- Positive Pressure Release Assembly (PPRA), 336
- Positive Pressure Relief (PPR), 186, 217
- postflight crew activities, 32
- Post Increment Evaluation Report, 17
- post-sleep time on ISS, 22–23
- potable water, 340
- Potable Water Dispenser (PWD), 344
- Power and Data Grapple Fixture (PDGF), 254–255, 256, 257
- power buses, 168
- power channels
  - cross-ties, 160
  - diagram of, 163
  - EPS design, 160
  - role in EPS, 159, 163
  - variations in output of, 161
- power distribution, 166
- power planning, 161
- power system. *See* Electrical Power System (EPS)
- power tools, 270
- prebreathe of oxygen prior to EVA depressurization, 298–299
- Predetermined Debris Avoidance Maneuver (PDAM), 148, 149–151
- Pre-Positioned Load (PPL), 105
- presleep time for crew, 24
- Pressure Control Assembly (PCA), 335–336
- pressure level of fluid lines in TCS
  - accumulator management, 197, 199–201
  - movement challenges, 363–365, 367–368
- pressurized habitat modules
  - assembly of, 38–41
  - internal cooling loops for, 205
  - in overall structure, 37
- Pressurized Mating Adapter (PMA) modules
  - movement of, xxi
  - PMA-2, xv, xvi, 40, 271
  - PMA-3, 67, 69, 70, 71, 72, 73, 86, 271
- Preventive Maintenance, 269
- Primary Power System, 163–165
  - batteries, 165
  - Battery Charge/Discharge Units (BCDUs), 165
  - overview, 156–157
  - power channel cross-ties, 160
  - sequential shunt units (SSUs), 165
  - solar arrays, 163–165
- Primary state, MDM, 100
- primary structure components, 36–46. *See also* Integrated Truss System
  - pressurized module assembly, 37, 38–41, 205
  - ready-to-latch requirement, 44–46
  - structural health, 42–43
- privacy for crew during off-time, 24, 28
- probability of collision (Pc), 145
- Probability of No Penetration, 48
- “probe-and-cone” docking system, Russian modules, 38
- problem recognition, training for, 177
- Product Water Tank, 344
- Program Office, USOS, xv
- Progress supply vehicles
  - attitude control from Russian Service Module, 120, 133
  - decrewing plan for, 213
  - docking system, 46, 235
  - loss of 44P and decrewing discussion, 210, 211, 214–215, 218–219
  - overview, xv, xvi, xviii
- propellant transport for reboost activities, 235, 236
- Proximity Operations mode, 106
- psychological support for crew
  - daily routines, 24, 29
  - holidays and time off, 3–4, 27–28
  - privacy during off-time, 24, 28
- public relations
  - Obama's call to crew, 82, 86
  - as role for crew and flight controllers, 29, 369
  - video live-streams to internet, 230–231
- pump accumulator quantity, 178
- pump and control valve package, 200
- Pump and Flow Control Subassembly (PFCS), 197, 199, 203
- Pump Module
  - changing out, 354, 358–359, 360, 362–363, 368, 370–376
  - jettison option, 365
  - location of, 362
  - process schematic, 200
  - workings of, 199–201
- ## Q
- Quick Disconnect (QD) problems, 360, 363–365, 367, 369, 370, 373–374
- ## R
- Rack Power Switch, 346
- racks, 54–58
  - Atmosphere Revitalization Rack, 338
  - avionics, 54, 57
  - crew support, 54
  - Fluids Integrated Rack (FIR), 58
  - installation process, xxii
  - Moderate Temperature TCS, 57
  - Node 3 installation, 84–85
  - payload, 54, 57, 58
  - Sabatier rack, 337, 344
  - and stowage space, 54
  - Window Observation Rack Facility, 51
- Radiator Beam Truss Structure, 203, 204
- Radiator Return valve, 359, 364, 366
- radiators
  - coordination with solar arrays, 157
  - process schematic, 200
  - radiator panels, 192, 202
  - role in Thermal Control System, 196–197, 202–204
  - Thermal Radiator Rotary Joint (TRRJ), 187, 200, 204, 356, 357, 358
  - Trailing Thermal Control Radiator (TTCR), 202, 203, 205
- Radio Frequency Group (RFG), 223
- radio frequency spectrum, 223. *See also* RF (radio frequency) links



Rapid Depress, 47–48, 143, 213, 217, 346–347, 348

Rassvet (“Dawn”) Mini Research Module (MRM)1, 253

Rate Gyro Assemblies (RGAs), 127

rate mode for rotating solar arrays, 169–170

Ray, John, 329

Ready to Latch (RTL) indicators, 39, 44–46

Reagan, Ronald, 251

Reboost mode

- propellant transport for, 235, 236
- purpose of, 106
- time of ignition (TIG), 134, 151

recirculation loops in Regenerative ECLSS, 215

recovery software, 105

recrewing, 218

Red orbital debris risk level, 145–146, 147

Redundancy Management (RM), 106

Regenerative ECLSS, 213–215

Regenerative Heat Exchanger, 206

Remote Bus Isolators (RBIs), 166, 167

remote control in EPS, 158–159

remote login to ISS, 227

Remote Power Controllers (RPCs), 166

Remote Power Control Modules (RPCMs), 94, 168, 216, 255–256

Remote Terminal (RT), 100

Renfrew, Royce, 261

research. *See* scientific research

respirators, 346, 347, 350

resupplying ISS. *See* visiting vehicles

return line, Active Thermal Control System, 197

return to Earth, 31, 32–33

RF (radio frequency) links, 223–228

- Ku-band, 97, 127, 216, 223, 224, 225–227
- S-band, 223–225
- ship-to-ship, 228
- UHF, 227–228, 287–288
- Wireless External Transceiver Assembly, 228, 230

robotics, 250–264. *See also* Space Station

- Remote Manipulator System (SSRMS) crew and ground control coordination case study, 260–262
- ground operations and FCT, 258–260
- Mobile Servicing System Operations (MSS), 258–264
- operational challenges and triumphs, 262–264
- Robotic Workstation (RWS), 46, 230, 242–243, 258
- Space Station Remote Manipulator System, 252–255
- Special Purpose Dexterous Manipulator, 255–256
- working with Ready to Latch indicators, 44

robotics and spacewalks activity category, 29

Robotics Officer (ROBO) team, xxvi, 258–260, 261, 262, 264

Robotic Workstation (RWS), 46, 230, 242–243, 258

Rocketdyne Truss Attachment System, 42

rocket thrusters. *See* thrusters

Roden, Sean, 329

roll ring structure, 169

Romanenko, Roman, 20

Ross, Jerry, 298

rotating joints for solar array adjustment, 168–169

rotational control. *See* attitude control

Russian Functional Cargo Block (FGB), 157

Russian partner agency. *See also* Soyuz crew vehicle

- Daily Planning Conference participation, 22
- investigation of Progress 44P loss, 218–219
- at MCC-H, xxvii
- as partner in ISS, xiv
- role in ISS development, xiv–xv

Russian Segment (RS), xiv. *See also* Service Module (SM)

- ammonia leak response, 175, 350
- Command and Control System interface, 93
- computer network, 93, 97
- debris shielding in, 49
- docking system, 31, 46, 235
- ETHOS coordination for life support system, 334
- GPS receivers, 126
- impact on solar array constraints, 170–171
- Motion Control System, 120, 121, 128, 133–135
- multiple duplicate units in computer system, 100
- power design differences from USOS, 156
- Rassvet (“Dawn”) Mini Research Module (MRM)1, 253
- round hatches of, 49
- structural comparison to USOS, 38–39
- systems backup limitations for USOS, 362

Russian (Orlan) spacesuit, 281, 283, 289

Ryazanskiy, Sergey, 361

## S

Sabatier, Paul, 344

Sabatier rack, 337, 344

safe haven procedures, 151, 153, 175

SAFER backpack unit, 282–283, 295, 298, 299, 301

“safing function” in managing EPS, 158

Sample Delivery System (SDS), 336

S-band Antenna Support Assembly, 310

S-band communication system, 223–225

scheduling changes

- generic skill-based training for crews, 4
- planning the ISS, 13–14
- tools for dealing with, 5, 15–16

science activity category, 29

Scientific Linux, 101

scientific research missions

- and crew time constraints, 14
- development of, xv
- life support for, 338
- microgravity maintenance for, 132
- NASA’s job in facilitating, xii–xiii, xv
- need for higher Ku-band link rate, 226
- negative impact of ammonia pump failure, 361
- planning of, 3, 5, 14
- Rassvet Mini Research Module 1, 253
- windows used for experiments, 51

Scopemeter, 270

“scratch pane” of window, 52

Secondary Power System, 165–171

- Direct Current Switch Unit (DCSU), 163, 166
- Direct-Current-to-Direct-Current Converter Units (DDCUs), 158, 161, 165–166
- jumpers, 68, 161, 215–216, 271
- longeron shadowing, 170–171
- Main Bus Switching Units (MBSUs), 160, 163, 167, 310
- overview, 157
- pointing systems, 168–170
- power buses, 168
- power distribution, 166
- Remote Power Control Modules (RPCMs), 168
- solar array constraints, 170

secondary structure components. *See also* docking systems

- closeout panels, 58–59
- hatches, 38, 49–50, 349
- orbital debris shielding, 46–49, 53, 141–143
- racks, 54–58. *See also* racks
- windows, 38, 50–53

Segment-to-Segment Attachment System, 42

sensors

- in Command & Data Handling System (C&DH), 94, 99
- dedicated and collateral for debris tracking, 143–144
- Orbiter Boom Sensor System (OBSS), 317, 320–322, 323, 327, 330

Sequential Shunt Units (SSUs), 163, 165

Service Module (SM), Russian Segment. *See also* thrusters

- attitude determination, 128
- Debris Avoidance Maneuver (DAM), 148–149
- Electrical Power System design for, 157
- Motion Control System for, 120, 121, 135
- windows of, 50

Service Module Central Computer (SMCC), 93, 97

Service Module Terminal Computers (SMTCs), 97

Shepherd, Chelsea, 33

ship-to-ship RF link, 228

Short Term Plan (STP), 5, 9–10, 11–12

“ShRECs,” xix

Sierra Nevada Corporation, 245

Simplified Aid for EVA Rescue (SAFER), 282–283, 295, 298, 299, 301

simulations. *See also* crisis simulations

- for decrewing, 218
- mission training role, 63, 76

- robotic arm maneuvers, 239–240
- software upgrade, 111
- visiting vehicle missions, 239
- single-loop configuration, ITCS, 206–207
- Single MT or Single LT mode for pumps, 178
- Skylab, xiii, 135
- sleep time for crew, 24
- Smith, Brian T., 243
- Smith, Steve, 298
- smoke detectors, 345–346
- “Snoopy” cap, EMU, 288
- software
  - state of charge (SOC) calculations, 162
  - updates to, 110–116
  - User Application Software, 105–106
- Solar Alpha Rotary Joints (SARJs)
  - Electrical Power System function, 160, 163, 168–169
  - issue with during STS-120/ISS-10A, 311–312, 313–314
  - and software upgrades, 111
  - structure of, 311, 312
  - vs. Thermal Radiator Rotary Joint (TRRJ), 204
  - in truss structure, 42
- solar array blankets, 163, 164, 316
- solar array masts, 163, 164, 170
- solar arrays, *See also* P6 solar arrays; P6 4B
- solar array repair; Solar Alpha Rotary Joints (SARJs)
  - in assembly of ISS, xix, xxi, 157, 164–165
  - battery charging/discharging, 157, 165
  - deployment of, 164
  - as electrical power sources, 156–157
  - location and size, 308
  - longeron shadowing, 170–171
  - motion control considerations, 124, 125
  - parking to accommodate visiting vehicles, 111, 170
  - power output, 161
  - power planning for, 162
  - in primary power system, 159–160, 163–165
  - retraction problems, 164–165
  - Sequential Shunt Unit (SSU) operation, 165
  - and software upgrades, 111
  - structure of, 164, 315–316
  - surface-on image of all, 156
  - thruster impact on, 131–132
  - and torque compensation, 132
- Solar Array Wing (SAW), 163, 164, 169, 315
- solar inertial attitude, 192–193
- solar radiation pressure impacting motion control, 129
- Solid Oxygen Generator “candles,” 335
- Solid State Mass Memory Units (SSMMUs), 99
- Soviet Union, xiv
- Soyuz crew vehicle
  - as crew transport, xix, 20–21
  - docked at ISS, xvi, 235
  - docking system, 31, 46, 235
  - as emergency escape vehicle, 348, 349, 350
  - landing of, 31

- Soyuz U and FG rockets, investigating fault with, 210
- space-based optical surveillance, debris tracking, 144
- Spacecraft Communicator Position (CAPCOM), xxv
- Space Integrated GPS/Inertial Navigation System (SIGI) receivers, 121, 126
- space junk. *See* orbital debris
- Space Operations Support Center (SOSC), xxviii
- Space Shuttle Program. *See also* making of a mission; *entries beginning with* STS and C&C MDM triple failure, 273
  - crew contribution to ISS assembly, 309
  - debris tracking and evaluation, 146
  - docking system, 39, 41, 46, 235
  - EMU design vs. ISS, 283, 285
  - EVA training vs. ISS, 294, 295
  - flight control vs. ISS, xxvii
  - planned EVA to test repair of orbiter tiles, 310–311
  - program defined, xiv
  - role in ISS development, xiii–xiv, xv
  - spacewalk role in ISS assembly, 281–282
  - transport role for ISS, xviii
- Space Shuttle Program Office, xv
- Space Station Freedom, xiii, xiv, 43, 44–45, 170–171, 225
- Space Station Integration and Promotion Center (SSIPC) (Tsukuba, Japan), xxviii
- Space Station Remote Manipulator System (SSRMS) (“big arm”), 251–255
  - in capturing visiting vehicles, 239, 254
  - challenges of bringing into operational status, 262–264
  - controlling from Cupola Workstation, 242
  - Control Moment Gyroscopes (CMGs) in, 120, 132
  - vs. EVA in planning ISS assembly tasks, 290, 291
  - grapple fixtures, SSRMS, 254–255, 256, 257
  - handling of OBSS during solar array repair, 317
  - ISS assembly role, 68, 252
  - joints and rotations, 252, 253, 254
  - location and appearance, 37, 252
  - in operation, 257
  - summary of properties, 251
  - vehicle berthing role, 239–240
  - working with during EVA, 250, 301–302
- Space Surveillance Network (SSN), 143, 145
- Space-to-Ground Antenna, 226
- Space-to-Ground Subsystem. *See* Ku-band communication system
- Space-to-Ground (S/G) voice loops, xxvii, 178, 224
- Space Transportation System (STS)
  - designations, xiv, xix. *See also entries beginning with* STS
- Space Vision System (SVS), 44

- spacewalk in detail (STS-120/ISS-10A), 306–331
  - flight days 1–3 (launch, rendezvous, motor check of SARJ), 311–312
  - flight days 4–5 (EVA 1: payload, Node 2), 312–313
  - flight days 6–7 (small scale distractions and SARJ inspection), 313–314
  - flight days 8–12 (P6 solar array repair), 314–330
  - last-minute added spacewalks, 310–311
  - lessons learned, 330–331
  - original mission, 307–308
  - planning, 309–310
    - Wheelock’s personal perspective, 322–323
- Spacewalks Position (EVA), xxvi
- SpaceX Control Center (MCC-X), xxviii, 246. *See also* Dragon (SpaceX) cargo vehicle
- Special Purpose Dexterous Manipulator (SPDM), 43, 255–256
- Standard MDMs, 98
- Standard mode, ISS, 106
- Standby state, MDM, 100
- Starboard Thermal Control Radiator, 202, 203
- Starboard Thermal Radiator Rotary Joint (TRRJ), 356, 357, 358
- Starliner crew vehicle, 246
- star mappers on Service Module, 128
- state of charge (SOC) software calculations, 162
- state vector in orbit determination, 125
- Station Power, Articulation, Thermal, and Analysis (SPARTAN), 161, 162, 171, 356, 358
- Station Support Computer (SSC), 93
- Stover, Scott, 36, 215, 329
- Stowage Officers (ISOs), 4
- stowage space, managing with racks, 54
- Stowage Tracking Position (CIO), xxv
- Structural Dynamics Measurement System, 42
- structures and mechanisms, ISS, 36–59
  - primary structure, 36–46, 205
  - secondary structure, 46–59, 141–143, 349
- Structures and Mechanisms Position (OSO), xxv
- STS-2, 251
- STS-92/ISS-3A, 39, 135
- STS-97/ISS-4A, 198, 252
- STS-98/ISS-5A, 40, 45, 54, 107, 135, 198, 252
- STS-100/ISS-6A, 47, 252, 259, 262, 271, 273
- STS-102/ISS-5A.1, 271
- STS-104/ISS-7A, 262, 272
- STS-110/ISS-8A, 135, 264, 292, 298
- STS-111/ISS-UF-2, 256, 263–264
- STS-113/ISS-11A, 228
- STS-114/ISS-LF-1, 78, 135, 274
- STS-115/ISS-12A, 203
- STS-118/ISS-13A.1, 120, 286, 311
- STS-119/ISS-15A, 156
- STS-120/ISS-10A, 164, 271, 301. *See also* spacewalk in detail
- STS-121/ISS-ULF1.1, 320–321
- STS-122/ISS-1E, 58, 330

STS-123/ISS-1J/A, 78–79, 255  
 STS-124/ISS-1J, 56  
 STS-126/ISS-ULF-2, 258  
 STS-127/ISS-2J/A, 227  
 STS-128/ISS-17A, 67  
 STS-129/ISS-ULF3, 46  
 STS-130/ISS-20A, 37, 40, 62. *See also* making of a mission  
 STS-132/ISS-ULF4, 226, 253  
 Stuffed Whipple Shield design, 48  
 sublimator, EMU cooling, 287  
 Suffredini, Mike, 369  
 sun, ISS orbit with respect to, 124–125  
 sun visor, EMU, 289  
 supply management, packing and loading, 3, 240–241. *See also* visiting vehicles  
 Suraev, Maxim, 27  
 Surgeon position (SURGEON), xxv  
 Survival mode, 106  
 Swanson, Steve, 291, 329  
 synchronizing watches for ground/space coordination, 22  
 System Flow Control Assembly Modulation Valve, 205  
 systems  
   Command and Data Handling (C&DH), 92–107  
   Communication and Tracking (C&T), 222–231  
   Electrical Power System (EPS), 156–171  
   Environmental Control and Life Support System (ECLSS), 334–350  
   ExtraVehicular Activities (EVAs), 280–303  
   Motion Control System (MCS), 120–136  
   robotics, 250–264  
   structures and mechanisms, 36–59  
   Thermal Control Systems (TCSs), 192–207

## T

Tani, Dan, 301, 309, 310, 313, 324  
 Tanner, Joe, 329  
 Team 4  
   for ammonia pump failure, 359–376  
   structure and function of, 359  
   for STS-120/ISS-10A issues, 314–318, 324, 329, 330–331  
 team interactions, training for, 177  
 technical water, 340  
 telemetry data, sending from ISS, 224  
 television on ISS, 27  
 temperature and humidity control. *See* Thermal Control Systems (TCSs)  
 Terminal Computer (RS), 121–122, 128, 134  
 tethers, EVA, 286, 291, 295, 296, 301  
 thermal control, EMU, 285, 287  
 Thermal Control Systems (TCSs), 192–207.  
   *See also* ammonia-based thermal transfer system  
   Active Thermal Control Systems (ATCSs), 192, 195–204  
   and computer systems installation, 107

decrewing adjustments to deal with humidity change, 213–215  
 in failure simulation, 178  
 jumper method for failures in, 161  
 overview, xxiv  
 Passive Thermal Control Systems (PTCSs), 192, 194–195  
 Thermal Control Systems Position (THOR), xxv  
 Thermal Radiator Rotary Joint (TRRJ), 187, 200, 204, 356, 357, 358  
 Thirsk, Bob, 20  
 Three Way Mixing Valve (TWMV), 196–197  
 thruster plume impingement, solar arrays, 170  
 thrusters  
   attitude control with, 129, 131, 133–134  
   higher orbit for debris avoidance, 148  
   location control with, 128–129  
   microgravity effect of, 132  
   motion control during assembly, 135  
   visiting vehicle rendezvous role, 240  
 Thrusters control mode, 134  
 Tier 1 of C&DH system (CCS), 93, 94, 95  
 Tier 2 of C&DH system (local tier), 93, 94, 95, 106  
 Tier 3 of C&DH system (user tier), 93–94, 96–97  
 “tiger team” (panel of experts), 75  
 Tile Repair Ablator Dispenser (T-RAD), 311  
 time, as critical parameter for C&DH, 100–101  
 Time Division Multiple Access digital system, 229  
 time of closest approach (TCA), orbital debris tracking, 145  
 time off for crew, 3–4, 27–28  
 time of ignition (TIG), reboost, 134, 151  
 time of single orbit, 122  
 time zone synchronization for ground/space coordination, 22  
 Todd, Kenneth, 24  
 tools  
   EVA, 294, 295–296, 303, 325, 330  
   in-flight maintenance, 269, 270  
 Torque Equilibrium Attitudes (TEAs), 133  
 Toxic Atmosphere (ATM)  
   ammonia leak, 174–175, 178, 184, 217, 347, 350  
   detection system for ammonia, 336  
 toxic chemical exposure, managing during EVAs, 205, 302–303, 365  
 Trace Contaminant Control System (TCCS), 338, 346  
 Tracking and Data Relay Satellite (TDRS), 13, 126, 183, 223, 227  
 tracking of debris, 143–144, 146–147  
 trade space, Pump Module change out, 362–363, 366  
 Trailing Thermal Control Radiator (TTCR), 202, 203, 205  
 training. *See also* simulations  
   communication, 176, 177–179  
   decrewing the ISS, 218

for EVAs, 68–69, 77, 290–295  
 flight controller, xxvii–xxviii, 175, 238–239  
 flight director as trainer, 76, 182–183  
 generic skill-based training for crews, 4  
 handover, 215, 218  
 making of a mission, 62–63, 75–79  
 microgravity, 294  
 scenario development, 179–181  
 spacesuit training in US and Russia, 283  
 STS-120/ISS-10A mission, 309  
 visiting vehicle, 238–239, 240  
 Trajectory Operations Officer (TOPO), xxv, 145, 146, 147, 151  
 Transmitter/Receiver/Controller, 226  
 Transponder, 223  
 trash bag, EMU, 296  
 trash removal at ISS, 235, 236  
 truss system. *See* Integrated Truss System  
 Tsukuba Control Center, xiii  
 Tures, Becky, 329  
 two-way video, 226–227  
 two-way voice/audio, UHF, 227–228, 287–288  
 Tyruin, Mikhail, 361

## U

UHF (Ultra-High Frequency) RF link, 227–228, 287–288  
 Ultrasonic Leak Detector (ULD), 52, 272  
 umbilical, airlock, 297, 300  
 Umbilical Mating Adapters, 256  
 United States On-orbit Segment (USOS). *See also* Command and Control System (CCS); Laboratory (Destiny) module  
 ammonia leak response, 350  
 Audio Terminal Units (ATUs), 229  
 and Common Berthing Mechanism interface, 41  
 computer network, 93  
 Daily Planning Conference participation, 22  
 debris shielding, 142  
 docking system, 46  
 evacuation for toxic atmosphere, 217  
 EVA role of, 281–282  
 GPS receivers, 125–126  
 life support system development, xv  
 Motion Control System (MCS), 120, 121, 128, 129–130, 132–135  
 overview, xiv  
 power system design and operation, 156–171  
 rack configuration in, 54  
 Rate Gyro Assemblies (RGAs), 127  
 structural comparison to Russian Segment, 38–39  
 USOS Thruster Only (USTO), 133  
 Unity, computer network, 93  
 unsticking hardware (fit issues), 273–274, 276  
 UOP Bypass Jumper, 216  
 uplink procedure for software upgrade, 112–113  
 Urine Processor Assembly, 341, 342, 343  
 US Commercial Crew Program, xv

US Common Hatch, 49  
US Department of Defense, orbital debris tracking by, 141  
User Application Software, 105–106  
USOS to RS power converters, 167  
utility connections in vestibule, 40  
Utility Outlet Panels (UOPs), 216  
Utility Transfer Assembly (UTA), SARJ, 169  
utilization time for crew (research), 3, 5

## V

vacuum chambers, EVA training, 294  
Vacuum Exhaust System (VES), 339  
Vacuum Resource System (VRS), 338–339  
Van Cise, Ed, 36  
vectors, Motion Control System (MCS), 122–125  
Venable, Mitch, 33  
Vent and Release Assembly (VRA), 336  
vestibule components, 40–41  
VHF communication system, 222, 223  
video  
    baseband communication, 230–231  
    of daily crew activities, 23  
    Ku-band transmission of from ISS, 226–227  
    wireless helmet cam, 228  
    wiring troubleshooting, 271  
video cameras, 230–231  
Virts, Terry, 31, 83  
Virtual Reality laboratory, 294, 295  
visiting vehicles, 234–246. *See also specific vehicles by name*  
    air tank deliveries, 335  
    capture and berthing operations. *See* berthing/unberthing operations; capture operations  
    cargo delivery and loading, 240–241  
    Commercial Crew Program, xix, 17, 21, 246  
    constraints on launch and return of, 237–238  
    crew coordination role, 239–240, 241–243, 260–261  
    day of arrival, 241–245  
    docking activity. *See* docking systems  
    importance of accurate positioning for, 123  
    loss of supply missions, dealing with, 210, 211, 214–215, 218–219, 234–235, 289  
    orbital adjustments to accommodate, 237, 240  
    parking of solar arrays to accommodate, 111, 170  
    Proximity Operations mode, ISS, 106  
    purpose and importance of, 234–235  
    scheduling, 237–238  
    software update planning, 113–114  
    timing importance of, 244  
    training for, 238–239, 240  
    unloading time, 243–244

Visiting Vehicles Position (VVO), xxvi  
voice loops in control room, xxvi–xxvii, 178, 224  
Volkov, Sergei, 28  
“Vomit Comet” aircraft, 294  
von Braun, Wernher, xiii

## W

Wakata, Koichi, 20, 33, 242, 361, 369, 370  
Walheim, Rex, 298  
Walker, Shannon, 270  
“Wall of EVA,” 281, 300–301  
Walz, Carl, 135  
Waste and Hygiene Compartment (WHC), 57, 341, 343  
waste water, 340, 341, 342, 343, 344  
water  
    recovery and management, 340–345  
    recycled from urine and sweat, 334, 340  
water-based thermal transfer system. *See* Internal Thermal Control Systems (ITCSs)  
water-in-helmet incident  
    concerns about during Pump Module change out mission, 355, 364, 365, 366  
    details of, 289, 290, 291  
Water Processor Assembly (WPA), 340, 341–345  
Water Recovery System, 344  
Weekly Lookahead Plan (WLP), 5, 7–9  
Weekly Plan Review, 27  
Weightless Environment Test System, Japan, 294  
weightlessness. *See* microgravity  
welcome-back events for returning crews, 32  
wet vs. dry cargo, 235  
Wheelock, Doug  
    ammonia line movement testing, 365  
    in Cupola, 51  
    emerging from EVA hatch, 297  
    P6 4B solar array repair, 309, 310, 316, 322–323, 325, 327–328  
    Pump Module change out role, 371, 376  
Whipple Shield, 53, 142  
Whitson, Peggy, 78, 309, 310, 319  
Williams, Dave, 120, 136  
Williams, Jeffrey, 27, 83, 238  
Williams, Sunita, 29, 296  
Wilmore, Barry “Butch,” 184  
Wilson, Stephanie, 309, 324  
Window Observation Rack Facility, 51  
windows, 38, 50–53  
Wireless External Transceiver Assemblies, 228, 230  
Wiseman, Reid, 242  
Wolf, Dave, 227  
Worksite Interface (WIF) Extender, 320, 327  
worksite preparation time, allowing for, 15  
Worksites along truss, 257

## X

X-Perpendicular Out of Plane (XPOP)  
reference frame, 125, 192–193

## Y

Yaw, Pitch, and Roll (YPR) definitions, 123  
Yellow orbital debris risk level, 145, 146, 147  
Yui, Kimiya, 33

## Z

Zamka, George, 309, 319  
Zvezda thrusters, 133





National Aeronautics and Space Administration

**Lyndon B. Johnson Space Center**

2101 NASA Parkway

Houston, Texas 77058

[www.nasa.gov](http://www.nasa.gov)

NASA-SP-2017-634